

Conditions d'utilisation des contenus du Conservatoire numérique

1- [Le Conservatoire numérique](#) communément appelé [le Cnum](#) constitue une base de données, produite par le Conservatoire national des arts et métiers et protégée au sens des articles L341-1 et suivants du code de la propriété intellectuelle. La conception graphique du présent site a été réalisée par Eclydre (www.eclydre.fr).

2- Les contenus accessibles sur le site du Cnum sont majoritairement des reproductions numériques d'œuvres tombées dans le domaine public, provenant des collections patrimoniales imprimées du Cnam.

Leur réutilisation s'inscrit dans le cadre de la loi n° 78-753 du 17 juillet 1978 :

- la réutilisation non commerciale de ces contenus est libre et gratuite dans le respect de la législation en vigueur ; la mention de source doit être maintenue ([Cnum - Conservatoire numérique des Arts et Métiers - http://cnum.cnam.fr](#))
- la réutilisation commerciale de ces contenus doit faire l'objet d'une licence. Est entendue par réutilisation commerciale la revente de contenus sous forme de produits élaborés ou de fourniture de service.

3- Certains documents sont soumis à un régime de réutilisation particulier :

- les reproductions de documents protégés par le droit d'auteur, uniquement consultables dans l'enceinte de la bibliothèque centrale du Cnam. Ces reproductions ne peuvent être réutilisées, sauf dans le cadre de la copie privée, sans l'autorisation préalable du titulaire des droits.

4- Pour obtenir la reproduction numérique d'un document du Cnum en haute définition, contacter [cnum\(at\)cnam.fr](mailto:cnum(at)cnam.fr)

5- L'utilisateur s'engage à respecter les présentes conditions d'utilisation ainsi que la législation en vigueur. En cas de non respect de ces dispositions, il est notamment passible d'une amende prévue par la loi du 17 juillet 1978.

6- Les présentes conditions d'utilisation des contenus du Cnum sont régies par la loi française. En cas de réutilisation prévue dans un autre pays, il appartient à chaque utilisateur de vérifier la conformité de son projet avec le droit de ce pays.

NOTICE BIBLIOGRAPHIQUE

NOTICE DE LA GRANDE MONOGRAPHIE	
Auteur(s) ou collectivité(s)	Perdonnet, Auguste
Auteur(s)	Perdonnet, Auguste (1801-1867)
Auteur(s) secondaire(s)	Polonceau, Camille (1813-1859)
Titre	Portefeuille de l'ingénieur des chemins de fer
Adresse	Paris : librairie scientifique-industrielle de L. Mathias (Augustin), 1843-1846
Collation	5 vol.
Nombre de volumes	5
Cote	CNAM-BIB 8 Le 85 (1), (2) et (4) et CNAM-BIB Fol Le 12 et 12 bis
Sujet(s)	Chemins de fer Chemins de fer -- Conception et construction Chemins de fer -- Matériel roulant
Permalien	http://cnum.cnam.fr/redir?8LE85
LISTE DES VOLUMES	Texte
	Atlas
	Légendes explicatives des planches
	Appendices
	2e appendice

NOTICE DU VOLUME	
Auteur(s) volume	Perdonnet, Auguste (1801-1867)
Auteur(s) secondaire(s) volume	Polonceau, Camille (1813-1859)
Titre	Portefeuille de l'ingénieur des chemins de fer
Volume	Portefeuille de l'ingénieur des chemins de fer
Adresse	Paris : librairie scientifique-industrielle de L. Mathias (Augustin), 1843-1846
Collation	1 vol. ([129] f. de pl.) : ill. ; 31 cm
Nombre de vues	282
Cote	CNAM-BIB Fol Le 12
Sujet(s)	Chemins de fer Chemins de fer -- Conception et construction Chemins de fer -- Matériel roulant
Thématique(s)	Transports
Typologie	Ouvrage
Langue	Français
Date de mise en ligne	06/04/2018
Date de génération du PDF	24/02/2022
Permalien	http://cnum.cnam.fr/redir?FLE12



Le 12

Le 12

*Texte 85
- 8 -
a*

PORTEFEUILLE

DE

L'INGÉNIEUR DES CHEMINS DE FER

PAR **MM. AUGUSTE PERDONNET**

ANCIEN ÉLÈVE DE L'ÉCOLE POLYTECHNIQUE
PROFESSEUR À L'ÉCOLE CENTRALE DES ARTS ET MANUFACTURES

ET **CAMILLE POLONCEAU**

DIRECTEUR DES CHEMINS DE FER D'ALSACE
ANCIEN ÉLÈVE DE L'ÉCOLE CENTRALE DES ARTS ET MANUFACTURES

Atlas

PARIS

LIBRAIRIE SCIENTIFIQUE-INDUSTRIELLE DE L. MATHIAS (Augustin)

QUAI MALAQUAIS, 15

1843 — 1846



TABLE DES PLANCHES
DU PORTEFEUILLE DE L'INGÉNIEUR DES CHEMINS DE FER.

Planches.	SÉRIE A.	SÉRIE B.	SÉRIE C.	SÉRIE D.	SÉRIE E.	Planches.	SÉRIE F.
1	— Profils en travers.	1	— Rails divers.	1	— Outils de poseurs du chemin de fer de Versailles (rive gauche).	17	— Nouvelle plaque tournante employée sur les chemins anglais.
2	— Profils en travers, tranchées et tunnels.	2	— Coussinets divers.	2	— Outils de poseurs anglais.	18	— Plaque tournante servant en même temps à peser le chargement des voitures.
3	— Remblais et tranchées diverses.	3	— Rails divers.	3	— Outils de poseurs des chemins de fer de Balle et de Thann.	19	
4		4	— Coussinets portant leurs rails.	4	— Outils de poseurs des chemins de fer de Versailles (rive gauche).	20	
5		5	— Rails divers.	5	— Détail des coussinets de croisement et de changement de voies du chemin de fer de Versailles (rive gauche).	21	
6		6	— Fabrication des rails.	6	— Dédail des coussinets de croisement et de changement de voies du chemin de fer de Versailles (rive gauche).	22	
7		7	— Soies circulaires pour couper les rails.	7		23	
8		8		8		24	
9		9		9		25	
10		10		10		26	
11		11		11		27	
12		12		12		28	
13		13		13		29	
14		14		14		30	
15		15		15		31	
16		16		16		32	
17		17		17		33	
18		18		18		34	
19		19		19		35	
20		20		20		36	
21		21		21		37	
22		22		22		38	
23		23		23		39	
24		24		24		40	
25		25		25		41	
26		26		26		42	
27		27		27		43	
28		28		28		44	
29		29		29		45	
30		30		30		46	
31		31		31		47	
32		32		32		48	
33		33		33		49	
34		34		34		50	
35		35		35		51	
36		36		36		52	
37		37		37		53	
38		38		38		54	
39		39		39		55	
40		40		40		56	
41		41		41		57	
42		42		42		58	
43		43		43		59	
44		44		44		60	
45		45		45		61	
46		46		46		62	
47		47		47		63	
48		48		48		64	
49		49		49		65	
50		50		50		66	
51		51		51		67	
52		52		52		68	
53		53		53		69	
54		54		54		70	
55		55		55		71	
56		56		56		72	
57		57		57		73	
58		58		58		74	
59		59		59		75	
60		60		60		76	
61		61		61		77	
62		62		62		78	
63		63		63		79	
64		64		64		80	
65		65		65		81	
66		66		66		82	
67		67		67		83	
68		68		68		84	
69		69		69		85	
70		70		70		86	
71		71		71		87	
72		72		72		88	
73		73		73		89	
74		74		74		90	
75		75		75		91	
76		76		76		92	
77		77		77		93	
78		78		78		94	
79		79		79		95	
80		80		80		96	
81		81		81		97	
82		82		82		98	
83		83		83		99	
84		84		84		100	

Planches.	Planches.	Planches.	Planches.
13 — Détails des ferrures des diligences du chemin de fer de Versailles (rive gauche).	6 — Détails de la charpente du wagon à marchandises à quatre roues du chemin de Strasbourg à Bâle.	7 — Wagons de terrassement des chemins de Londres à Birmingham et de Londres à Bristol.	18 — Ateliers du chemin de fer de Strasbourg à Bâle, près de Mülhouse.
14 — Détails des ferrures des wagons des chemins de fer de Versailles (R. G.) et de Strasbourg à Bâle.	7 — Détails de wagon pour le transport des marchandises et pour celui des diligences.	8 — Détails des ferrures des wagons de terrassement du chemin de fer de Londres à Bristol.	19 et 20 — Première partie de la gare de Paris au chemin de fer de Paris à Orléans (voyageurs et bagages).
15 — Voitures des chemins de Londres à Birmingham et de Bâle à Strasbourg.	8 — Wagons à bagages, à marchandises et à lait du chemin de fer de Paris à Rouen.	9 — Détails des ferrures des wagons de terrassement du chemin de Londres à Birmingham.	21 et 22 — Deuxième partie de la gare de Paris du chemin de fer de Paris à Orléans (marchandises et ateliers).
16 — Détails des ferrures des voitures des chemins de fer de Londres à Birmingham, Southampton, Orléans.	9 — Détails d'un wagon à marchandises du chemin de Londres à Birmingham.	10 — Wagons de terrassement du chemin de fer du Nord et des chemins de fer de Rouen et du Havre.	23 et 24 — Gare d'Orléans du chemin de fer de Paris à Orléans.
17 — Roues diverses de voitures.	10 — Wagons pour le transport des chevaux.	11 — Détails des wagons de terrassement des chemins de fer du Nord et de Rouen.	25 — Stations de Mantès et Vernon, sur le chemin de fer de Paris à Rouen.
18 — Essieux divers.	11 — Wagons de marchandises et wagon-trécin employé sur le plan incliné de Liège.	SÉRIE IX.	
19 — Voitures du chemin de Rouen.	1 — Grues hydrauliques des chemins de fer de Versailles (rive gauche), de Saint-Germain et de Londres à Southampton.		
20 — Détails des voitures du chemin de fer de Paris à Rouen.	2 — Grues hydrauliques du chemin de Bâle à Strasbourg.		
21 — Détails des voitures du chemin de Londres à Bristol.	3 — Grues hydrauliques des chemins de fer de Paris à Orléans.		
22 — Voitures diverses du chemin de St-Etienne à Lyon.	4 — Grues hydrauliques du chemin de Bâle à Strasbourg.		
23 — Détails des voitures des chemins de Saint-Etienne à Lyon.	5 et 6 — Grues hydrauliques des chemins de Londres à Birmingham et de Newcastle à Carlisle.		
24 — Voitures du chemin de fer badois.	SÉRIE J.		
25 — Freins employés pour les wagons de voyageurs et de bagages des deux chemins de Paris à Orléans et à Rouen.	1 — Balcons pour remblais de diverses hauteurs.		
26 — Nouveaux ressorts employés en Angleterre, en Allemagne et en France.	2 — Changement et croisement de voies pour terrassement.		
SÉRIE G.			
1 — Wagons à bagages des chemins de fer de Paris à Orléans et à Saint-Germain.	3 — Changement de voies pour terrassement.		
2 — Wagons divers pour le transport des marchandises et des voitures.	4 — Changement et croisement de voies pour terrassement, et poulie de plan automate employée au chemin de fer de Versailles (rive gauche).		
3 — Wagons divers pour le transport de la houille et des marchandises.	5 — Wagons de terrassement des chemins de fer de Versailles (rive gauche) et de Saint-Germain.		
4 — Wagon à huit roues et wagon à quatre roues pour le transport des marchandises du chemin de Strasbourg à Bâle.	6 — Détails des ferrures des wagons de terrassement des chemins de fer de Versailles (rive gauche) et de Saint-Germain.		
5 — Détails du wagon à huit roues du chemin de fer de Strasbourg à Bâle.			

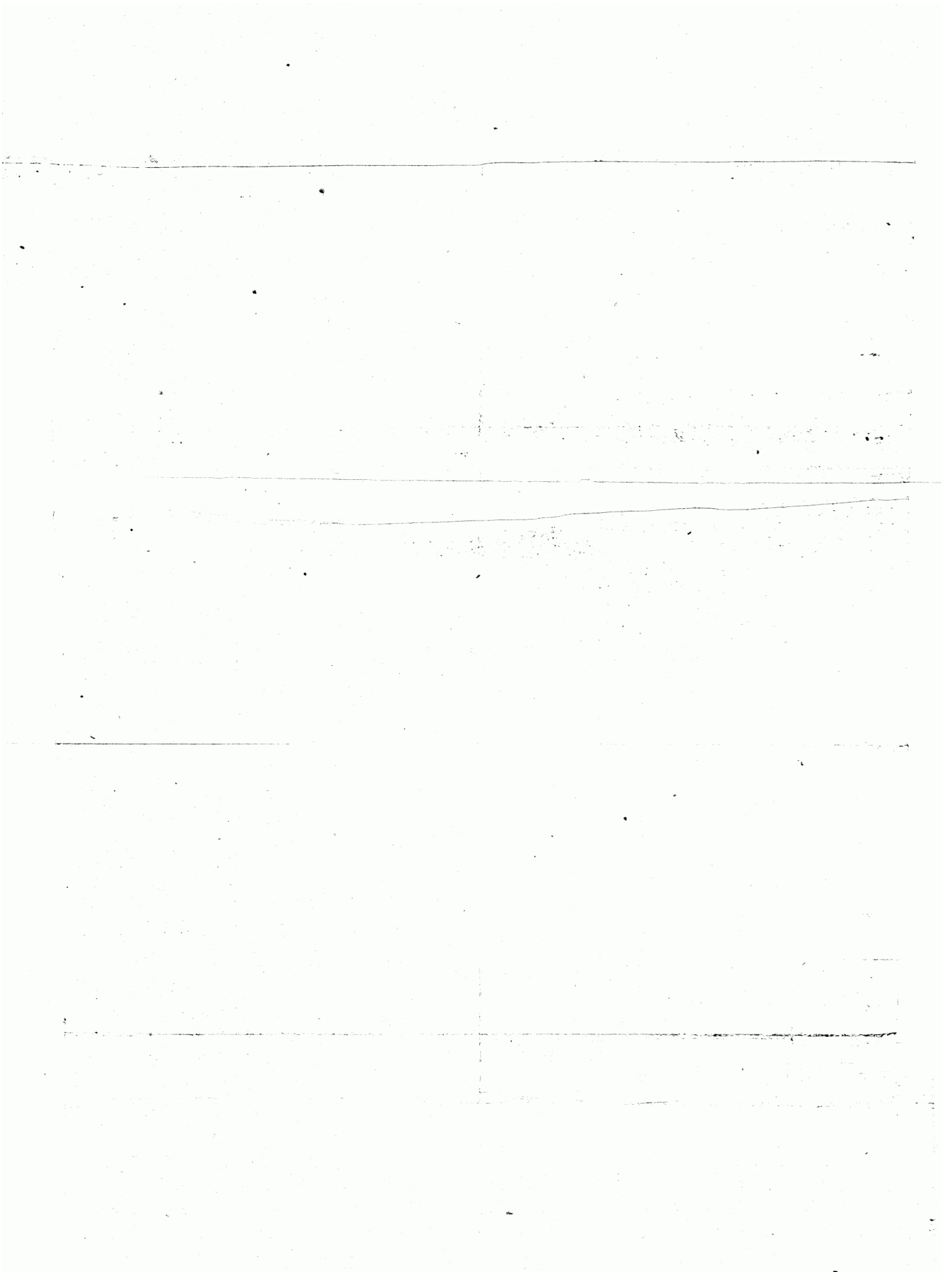

Profils en travers.

Fig. 1.

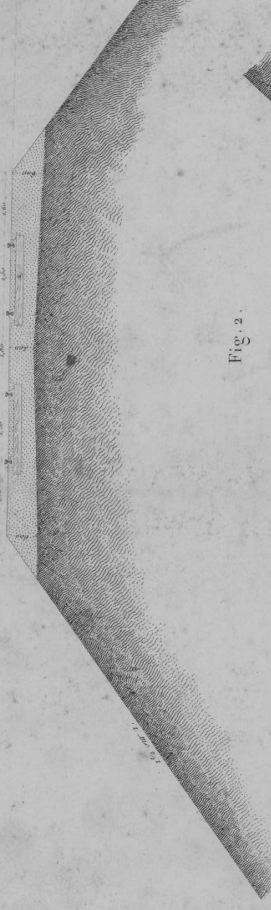

Fig. 2.

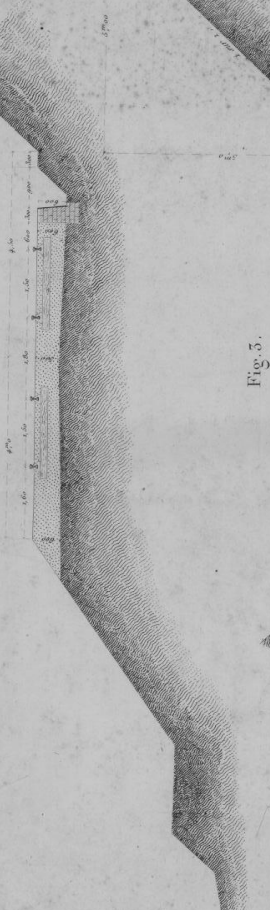

Fig. 3.

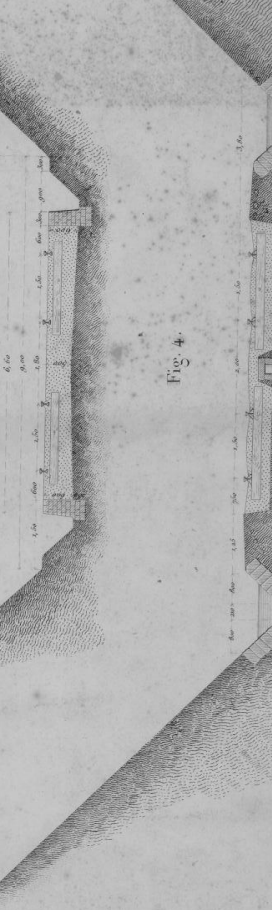

Fig. 4.

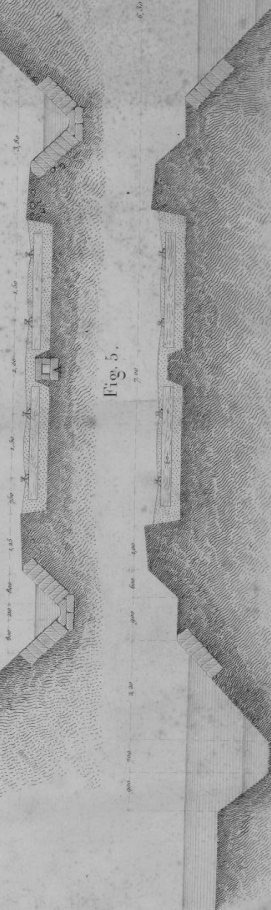

Fig. 5.



Fig. 6.



Fig. 7.

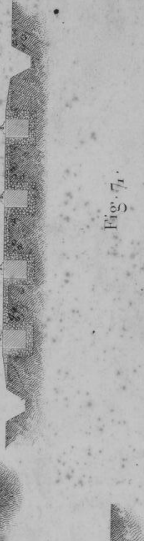

Fig. 7.

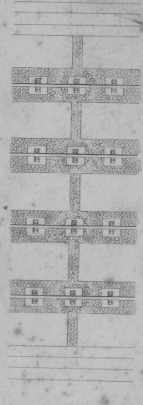

Fig. 8.

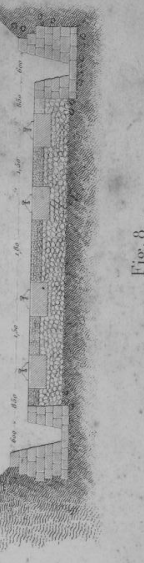
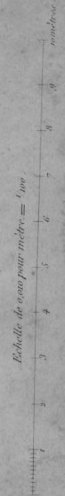
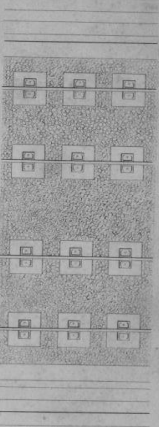

Fig. 8.



1/100
Echelle de cent pour mètre = 1/100
mètres

J. Mathieu & Co. Paris, quai de Valenciennes, 11.

J. Mathieu del.

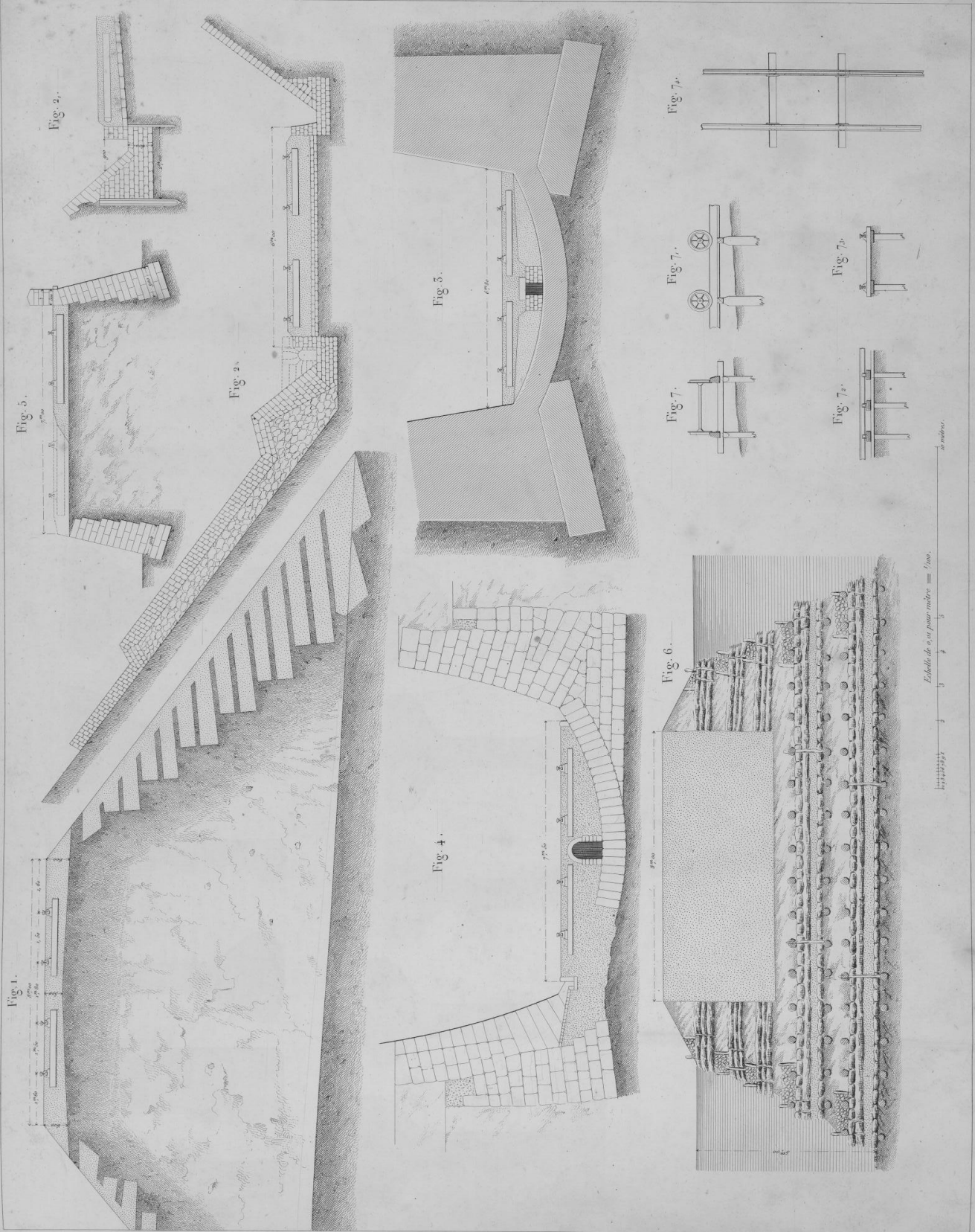



Rails divers.

B. I.

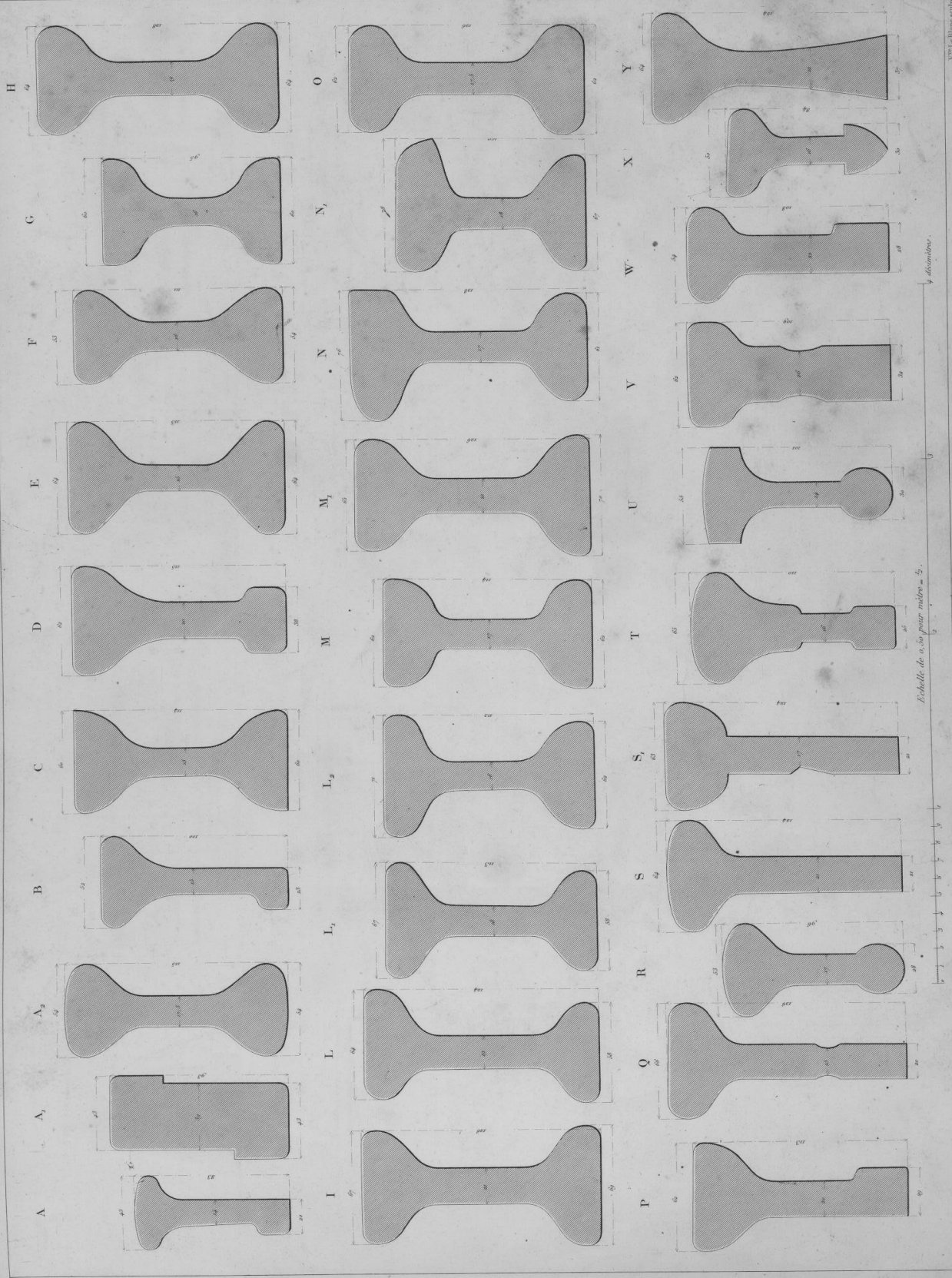

Paris Mathias, direct.

Les Mathias, Editeur, quai d'Orléans, 15.

Yves LeBlanc sculp.

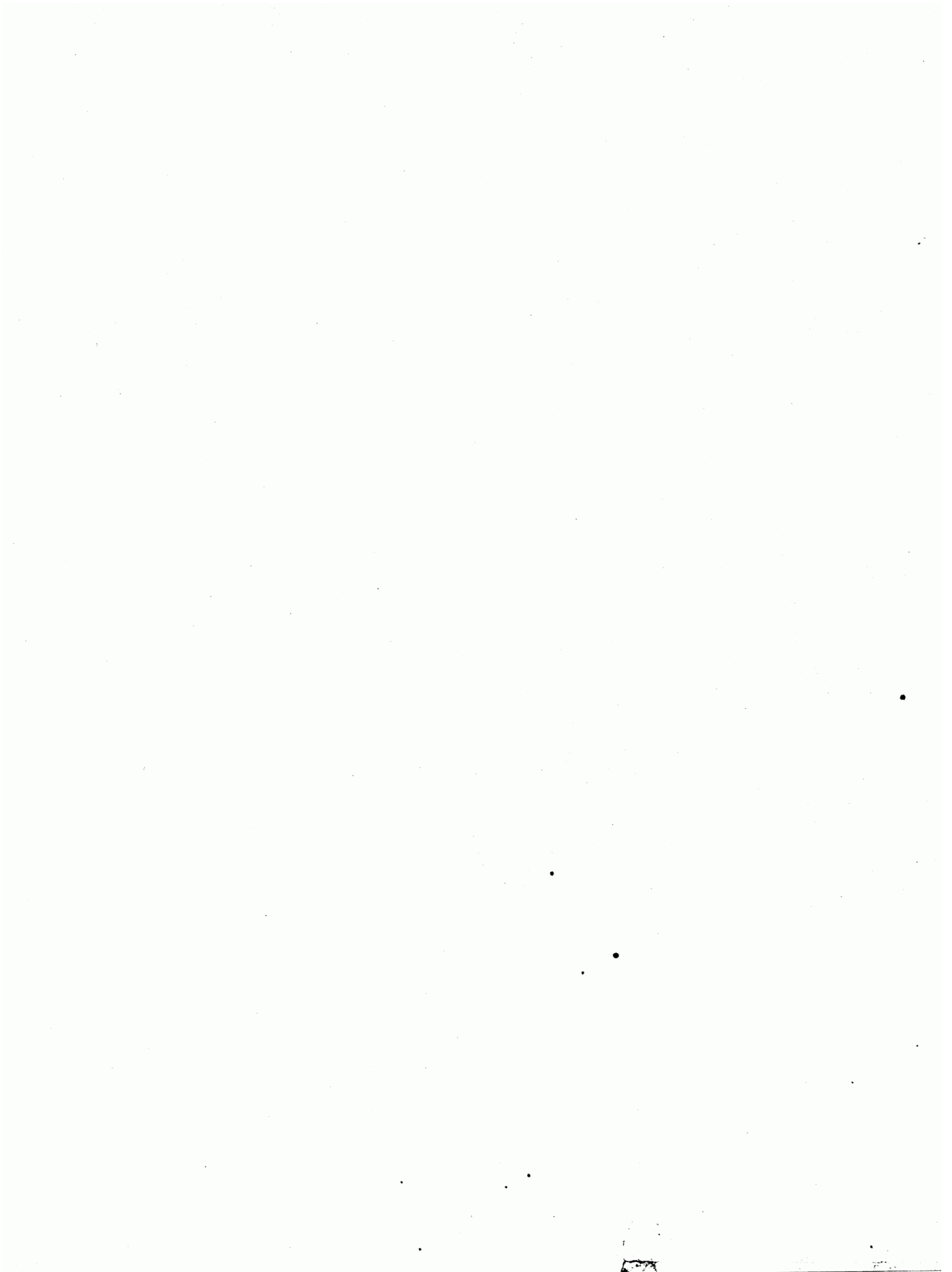

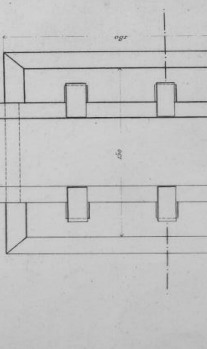
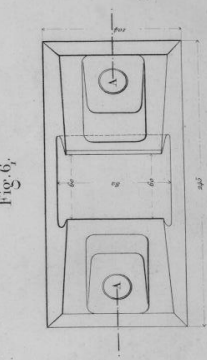
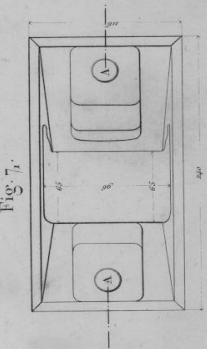
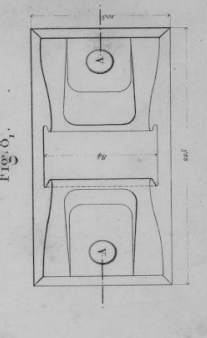
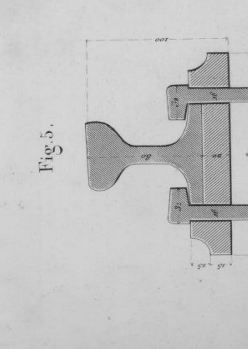
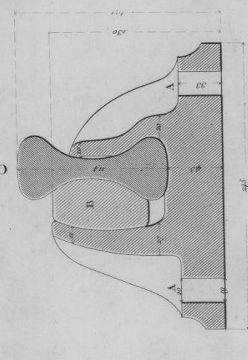
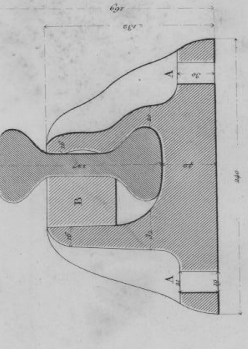
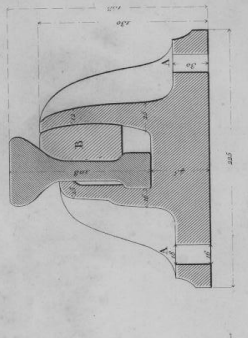
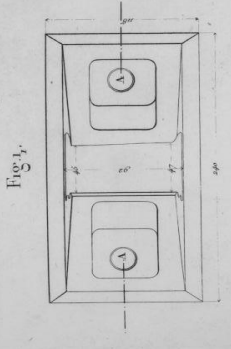
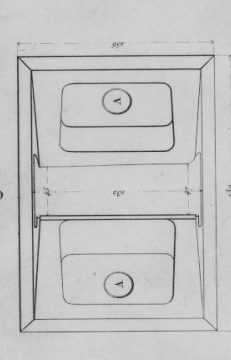
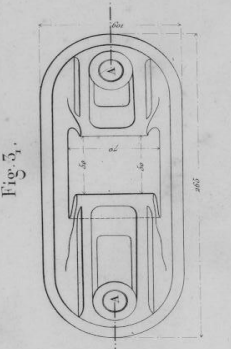
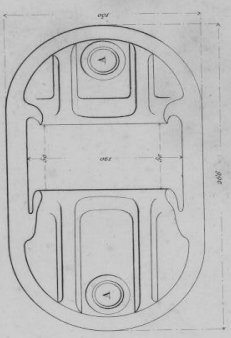
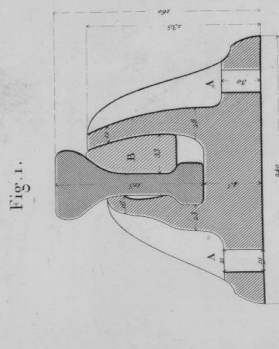
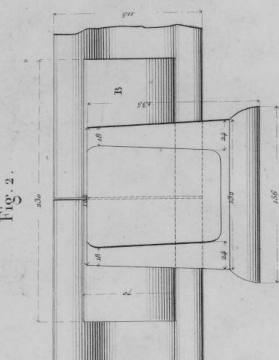
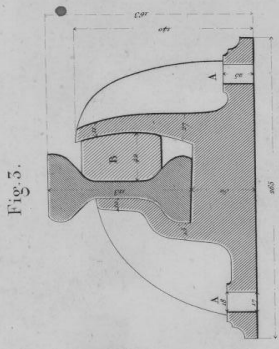
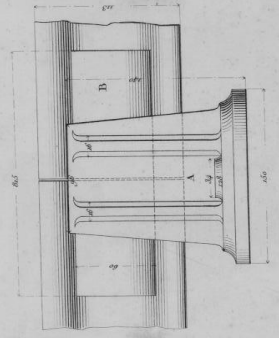

Échelle de 1/20^e pour toutes les figures.

Rails anglais et américains.

B. 5.

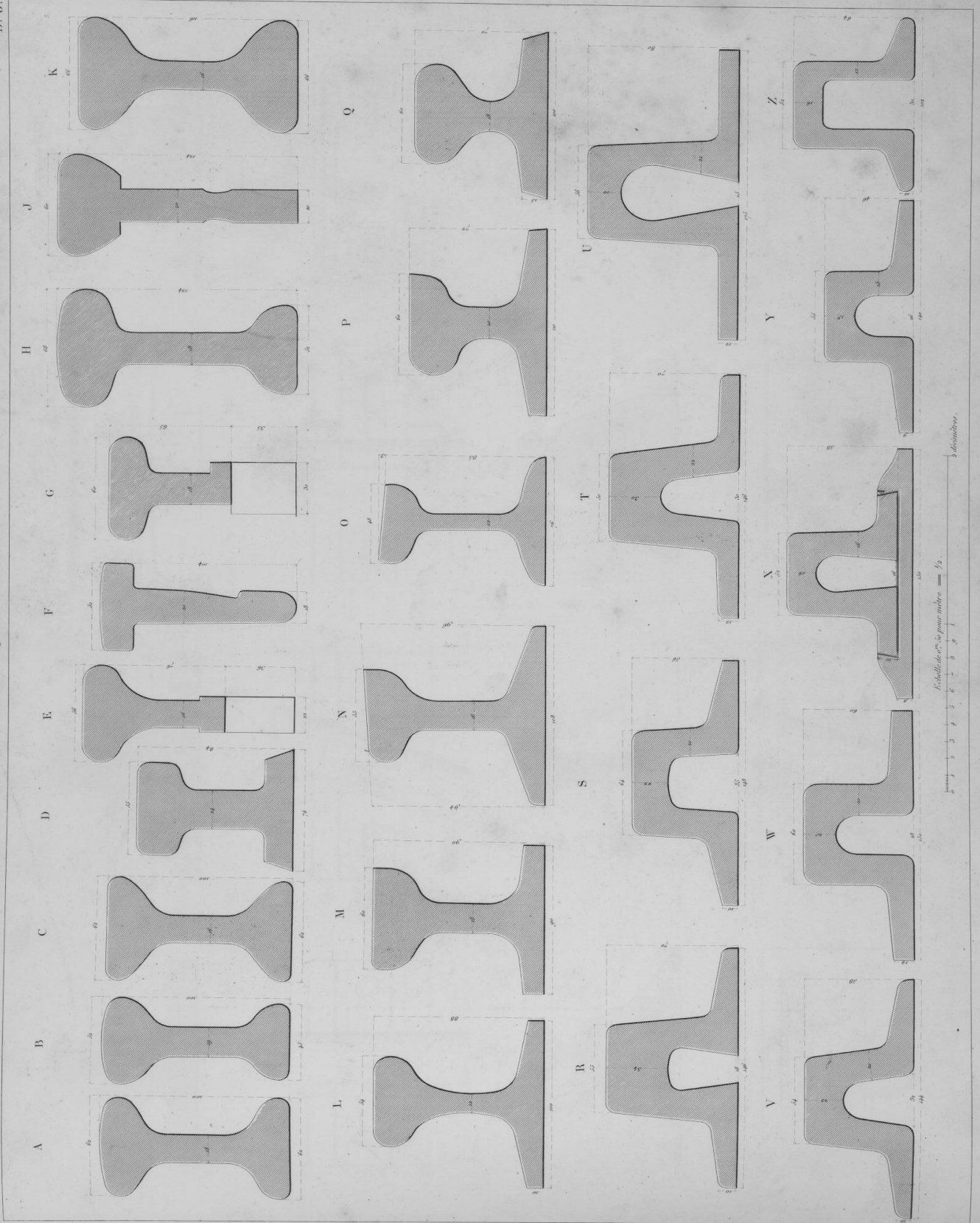



Fig. 1.

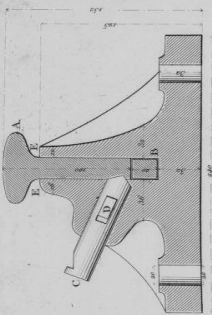

Fig. 2.

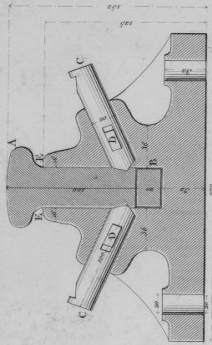

Fig. 2.

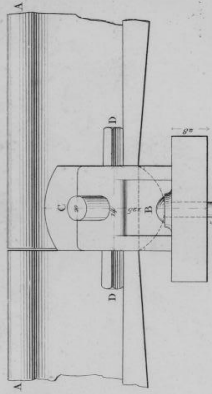

Fig. 3.

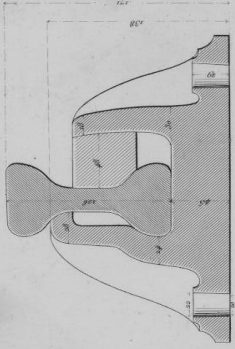

Fig. 1.

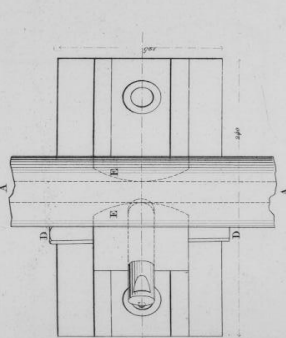

Fig. 2.

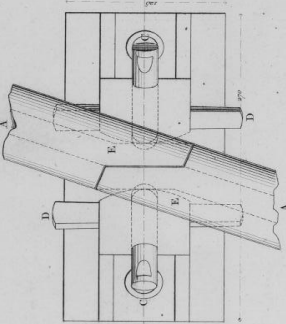

Fig. 2.

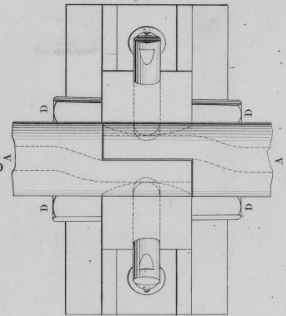

Fig. 3.

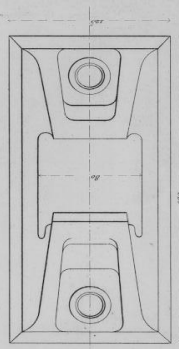

Fig. 4.

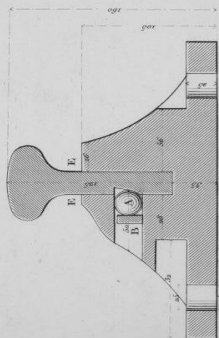

Fig. 4.

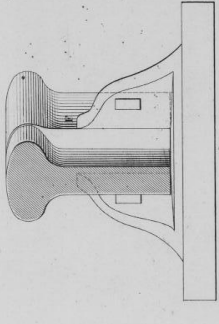

Fig. 5.

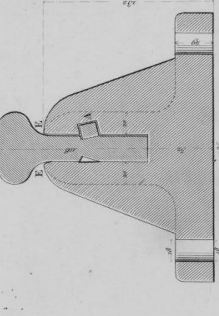

Fig. 6.

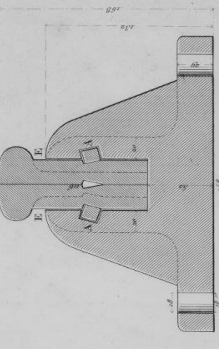

Fig. 4.

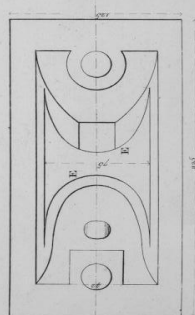

Fig. 4.

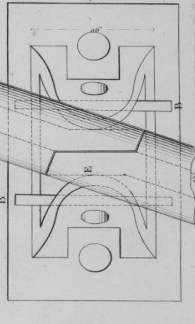

Fig. 5.

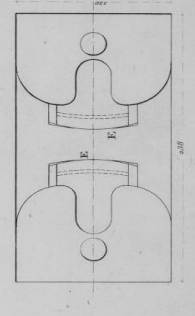
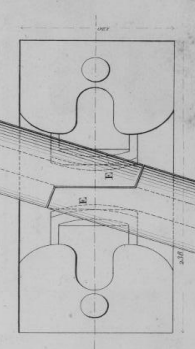
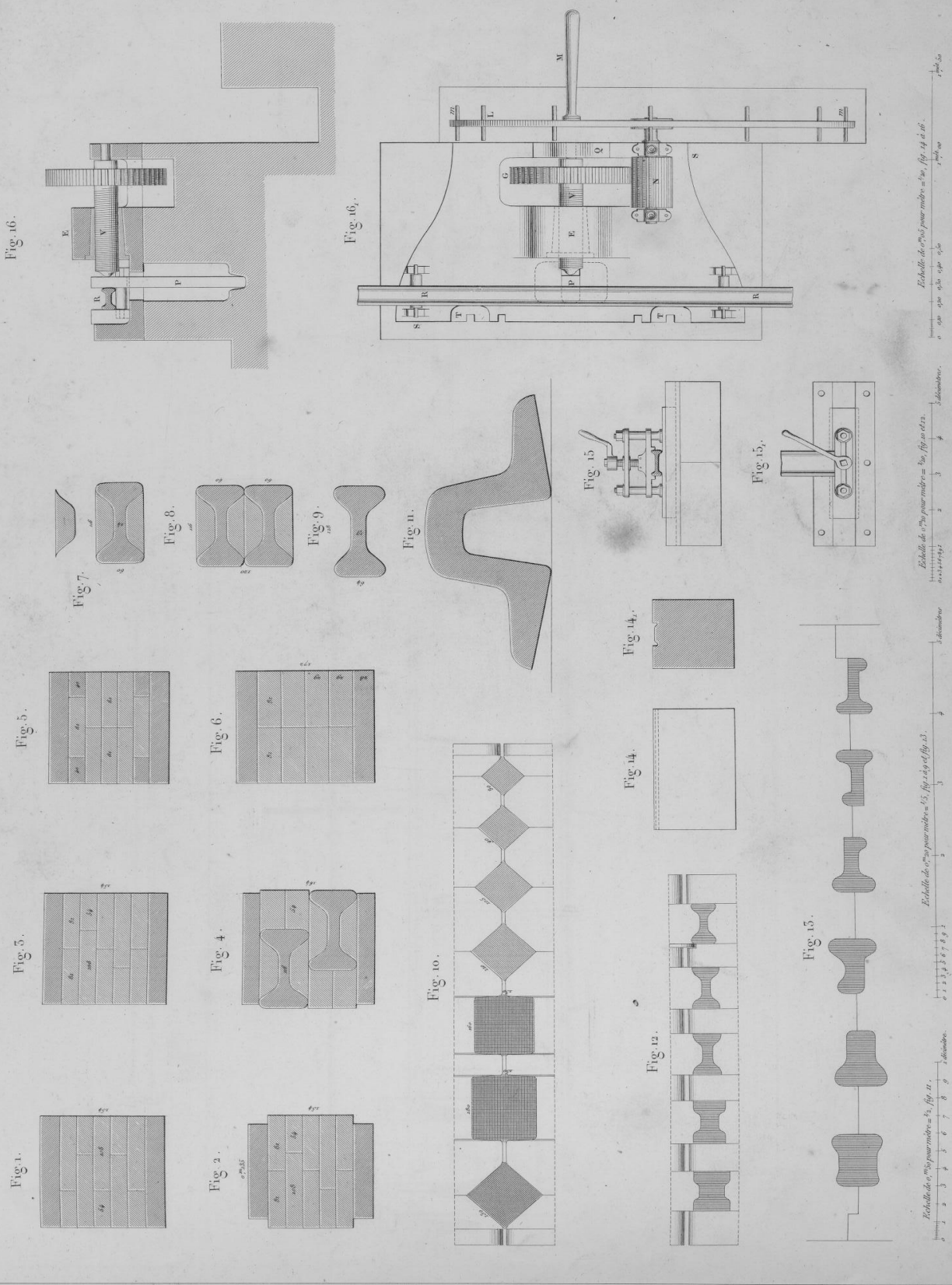

Fig. 6.



Echelle de 0,25 pour meter = 1/4
5 centimetre.





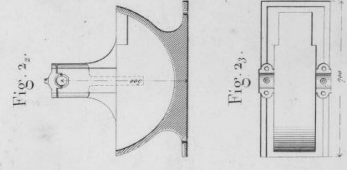
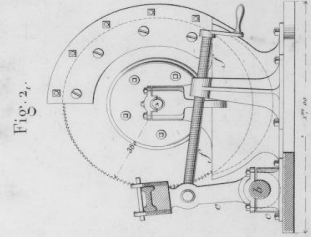
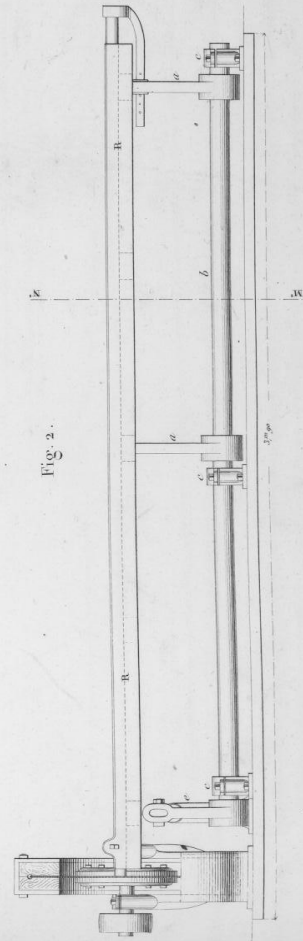
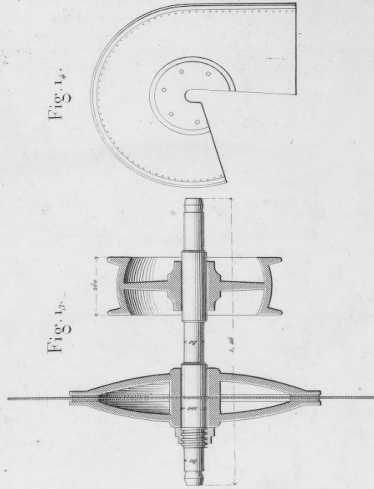
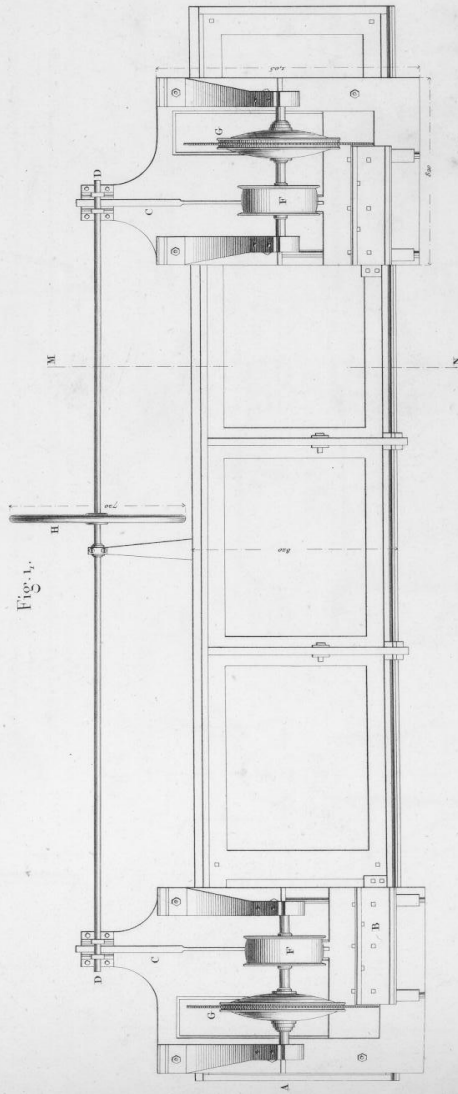
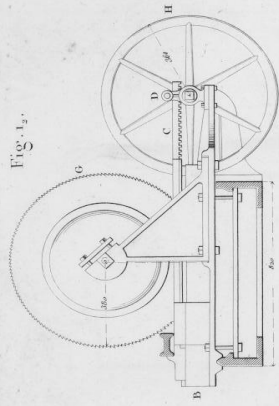
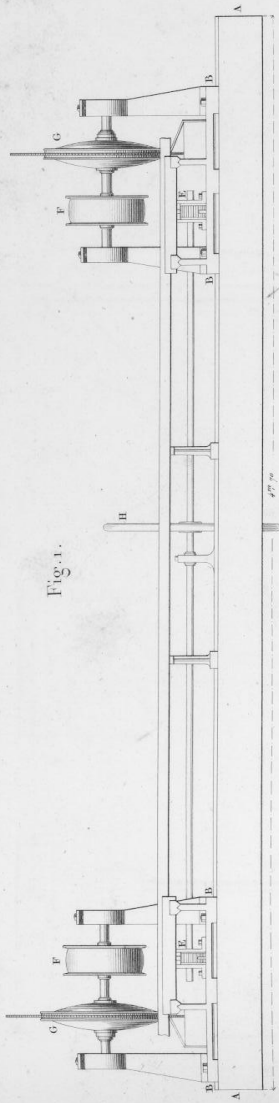

Echelle de 0,05 pour mètre = 50.

1 mètre.

Echelle de 0,10 pour mètre = 50.

1 mètre.

Outils de poseurs.

C. I.

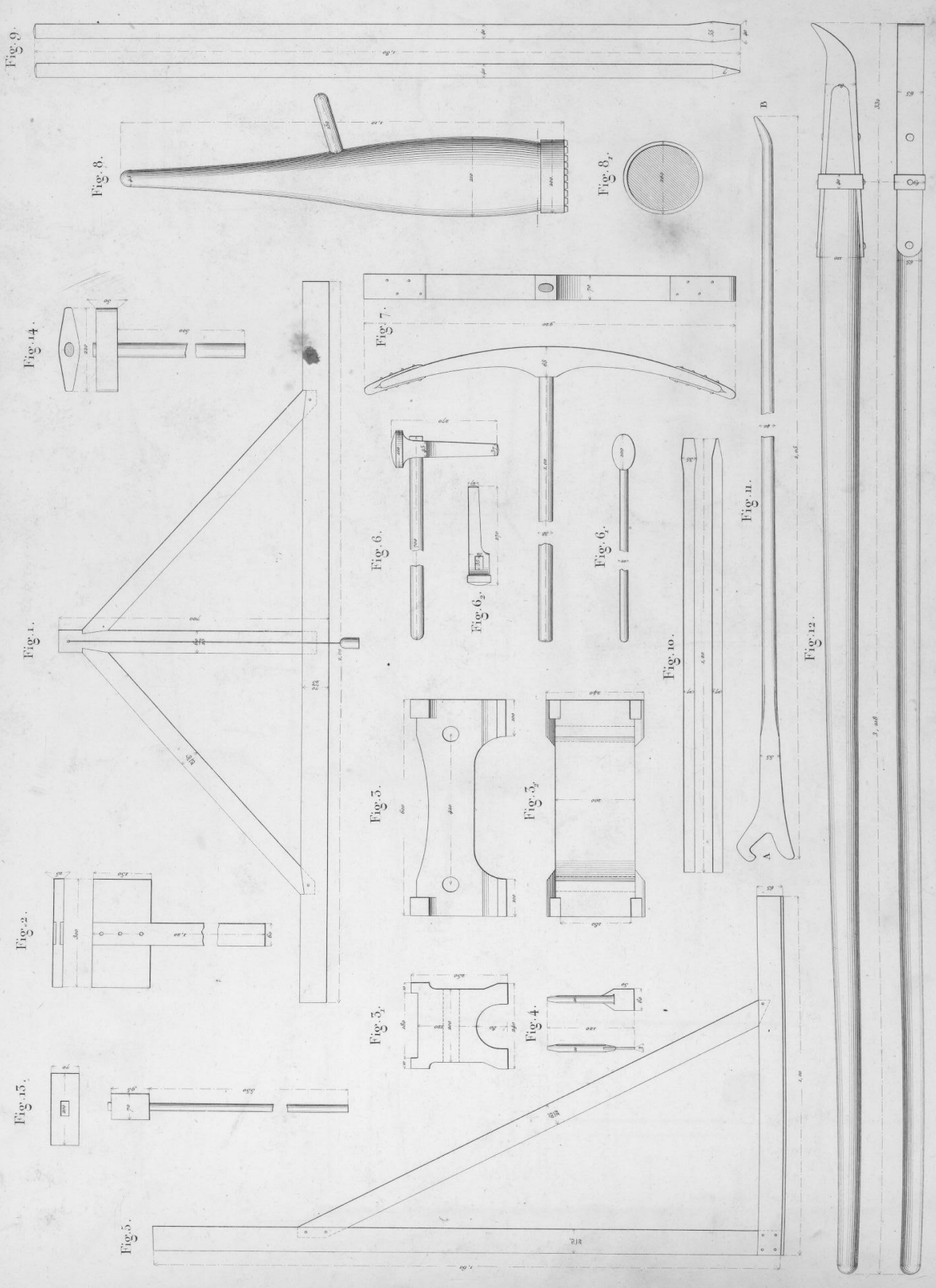

Echelle de 0,10 pour mâture - 50.
0 1 2 3 4 5 6 7 8 9 10 centim.

L. Mathis, Editeur, quai Malakoff, 55.

V. Le Blanc sculp.

E. Mathis del.



Outils de poseurs anglais.

Fig. 2.

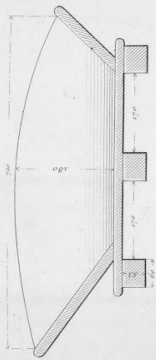

Fig. 11.

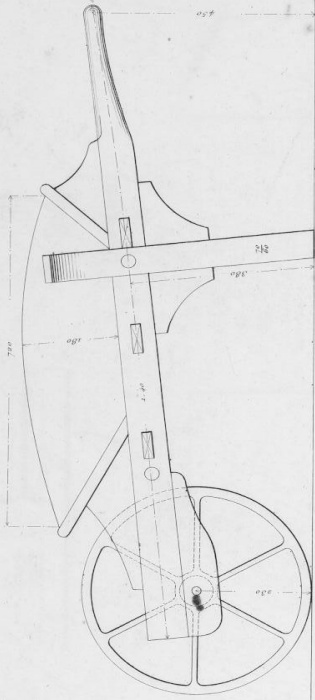

Fig. 5.

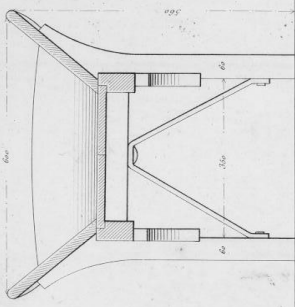

Fig. 4.

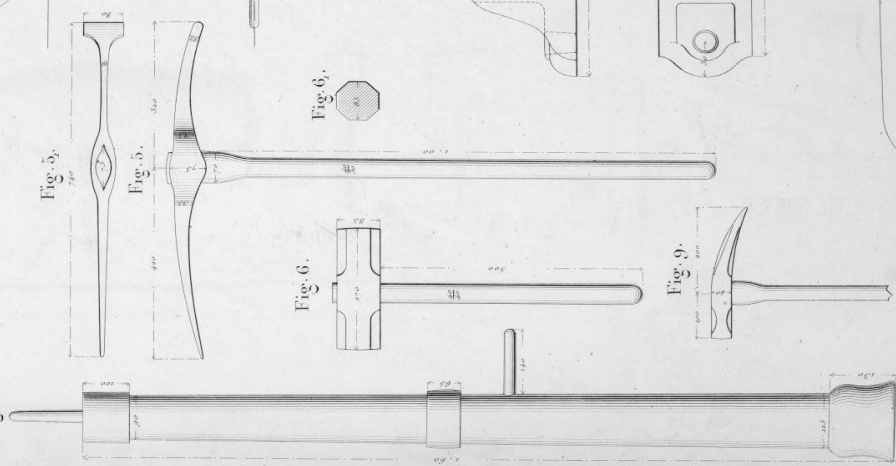

Fig. 5.



Fig. 5.

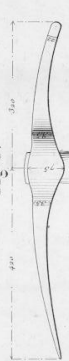

Fig. 6.

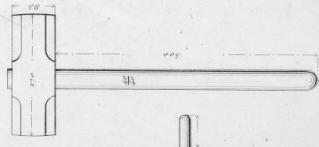

Fig. 6.



Fig. 1.

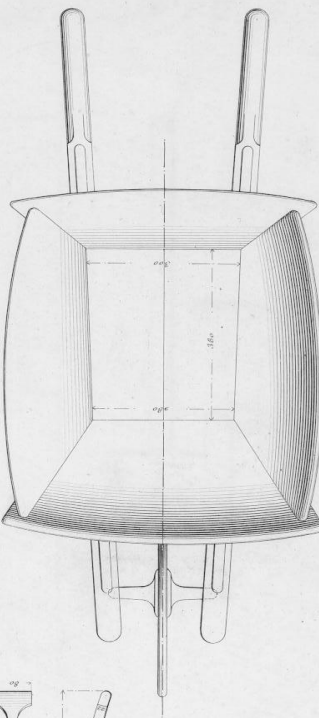

Fig. 10.

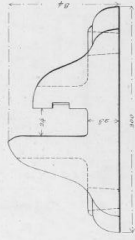

Fig. 8.

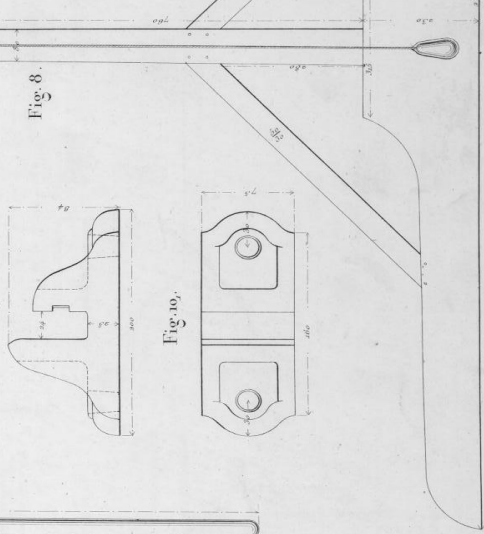

Fig. 11.

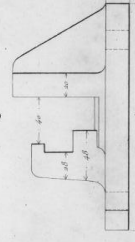

Fig. 12.

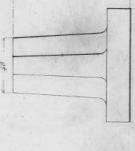

Fig. 16.

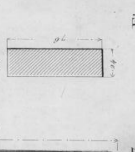

Fig. 7.

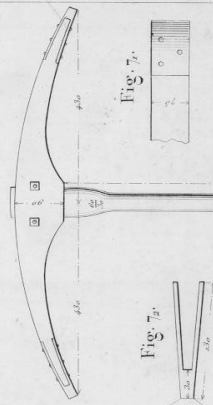

Fig. 7.



Fig. 13.

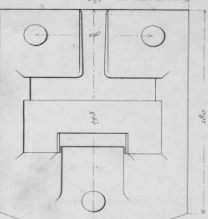

Fig. 14.



Fig. 14.



Fig. 15.

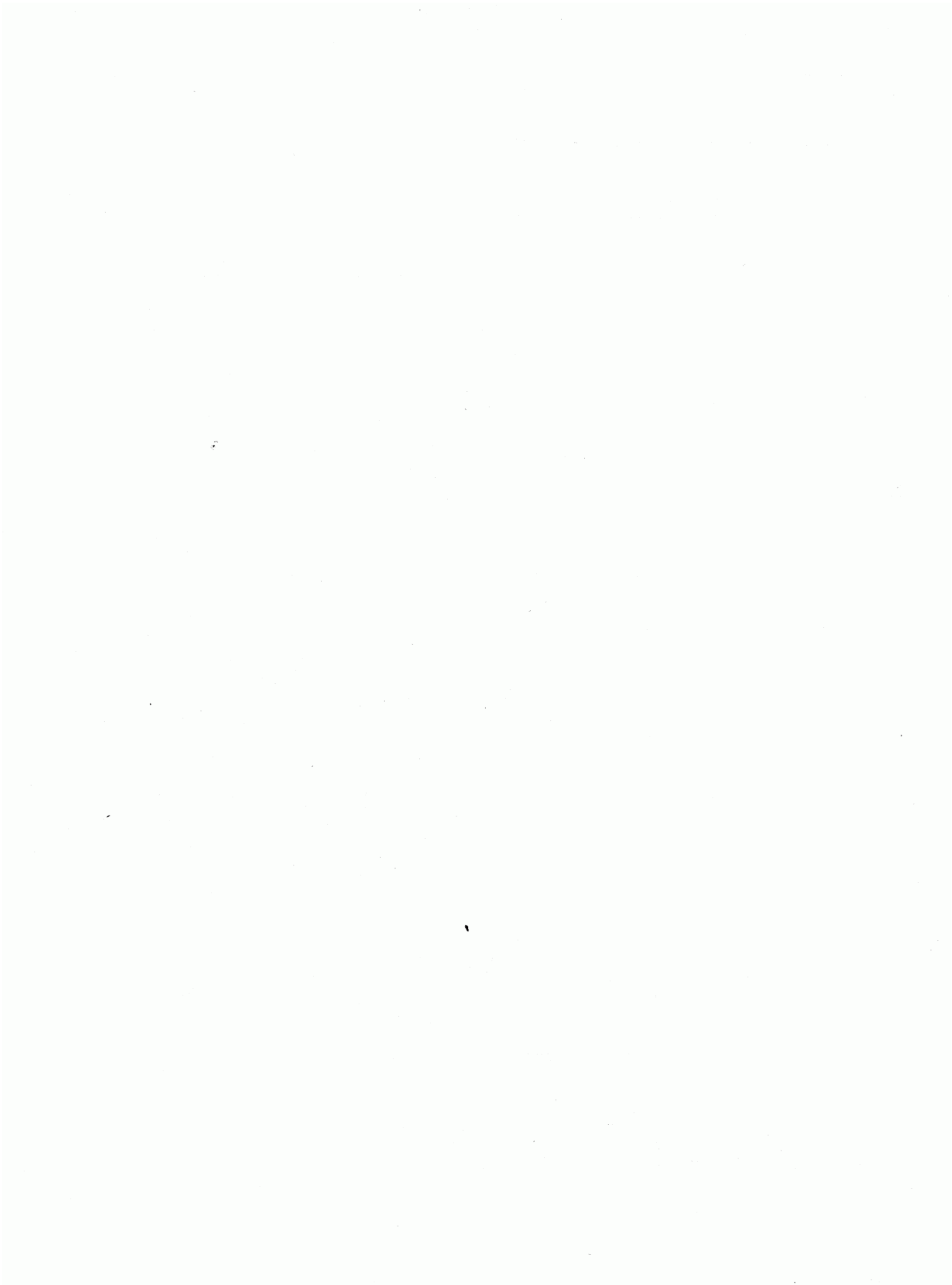

Fig. 15.



Echelle de 0.010 pour moitié pour les outils.

Echelle de 0.010 pour moitié pour les vis et boulons.



Outils de poseurs du chemin de Strasbourg à Bâle.

C. 5.

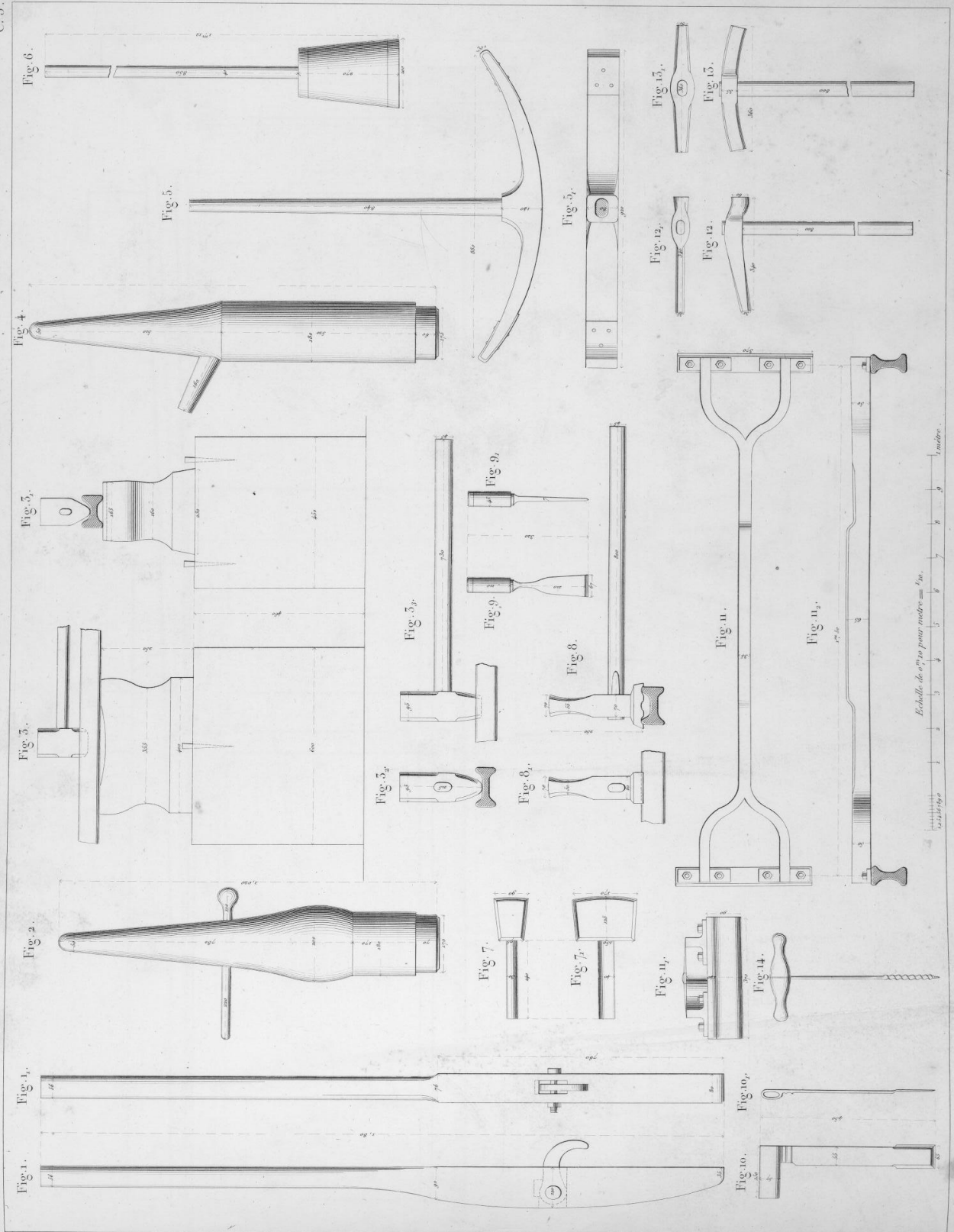

Changement de voies du chemin de fer de Versailles (R.G.).

D. 1.

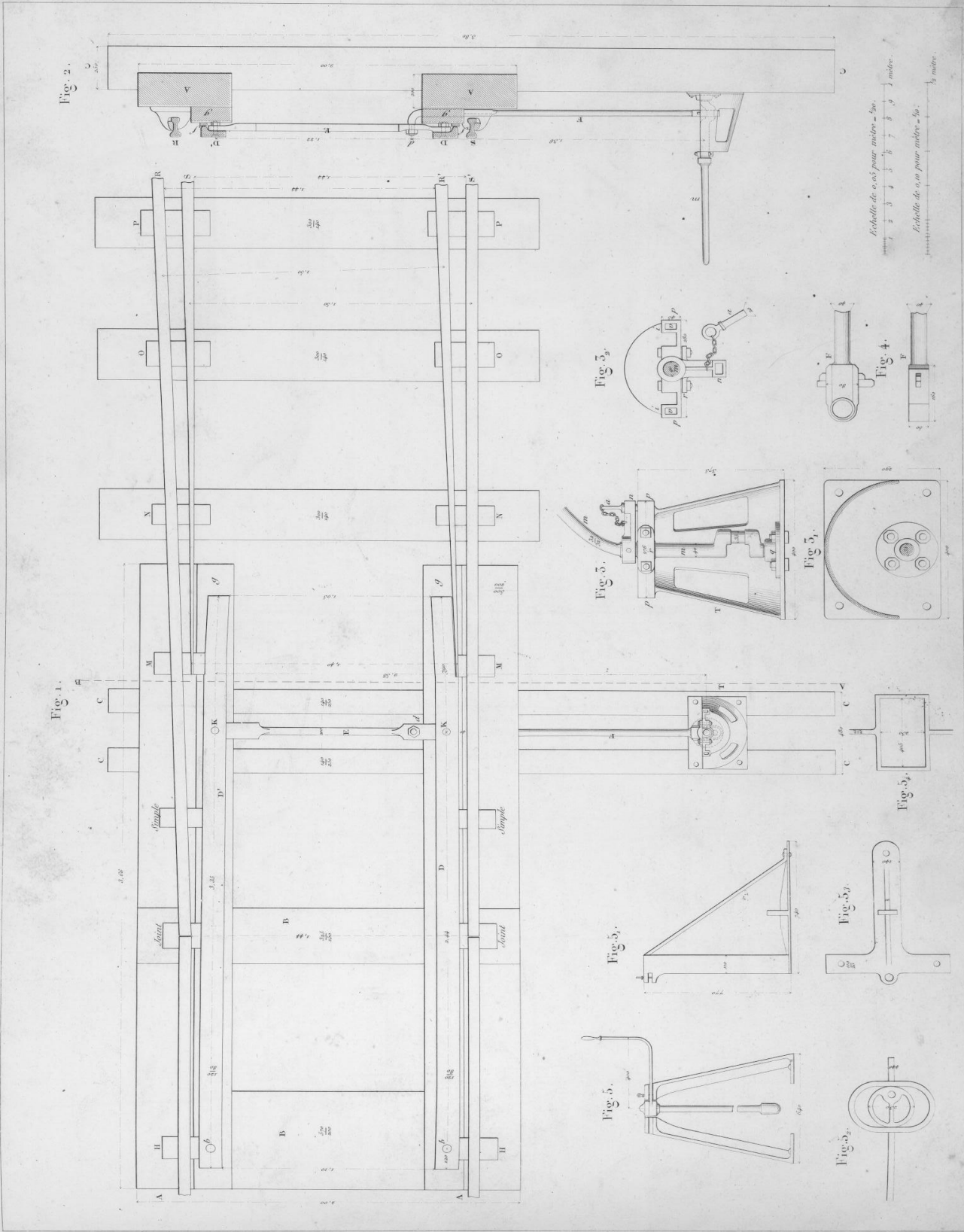

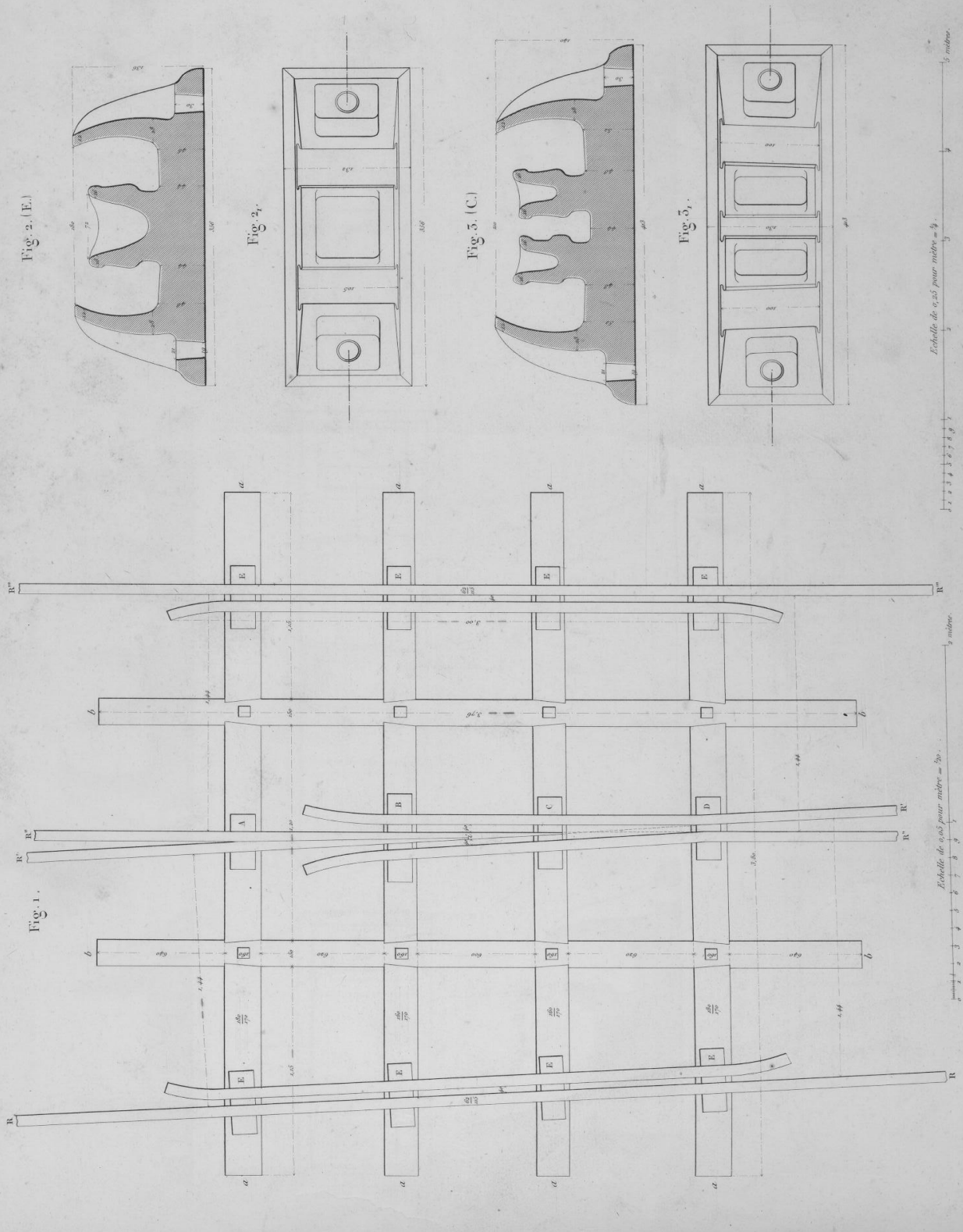



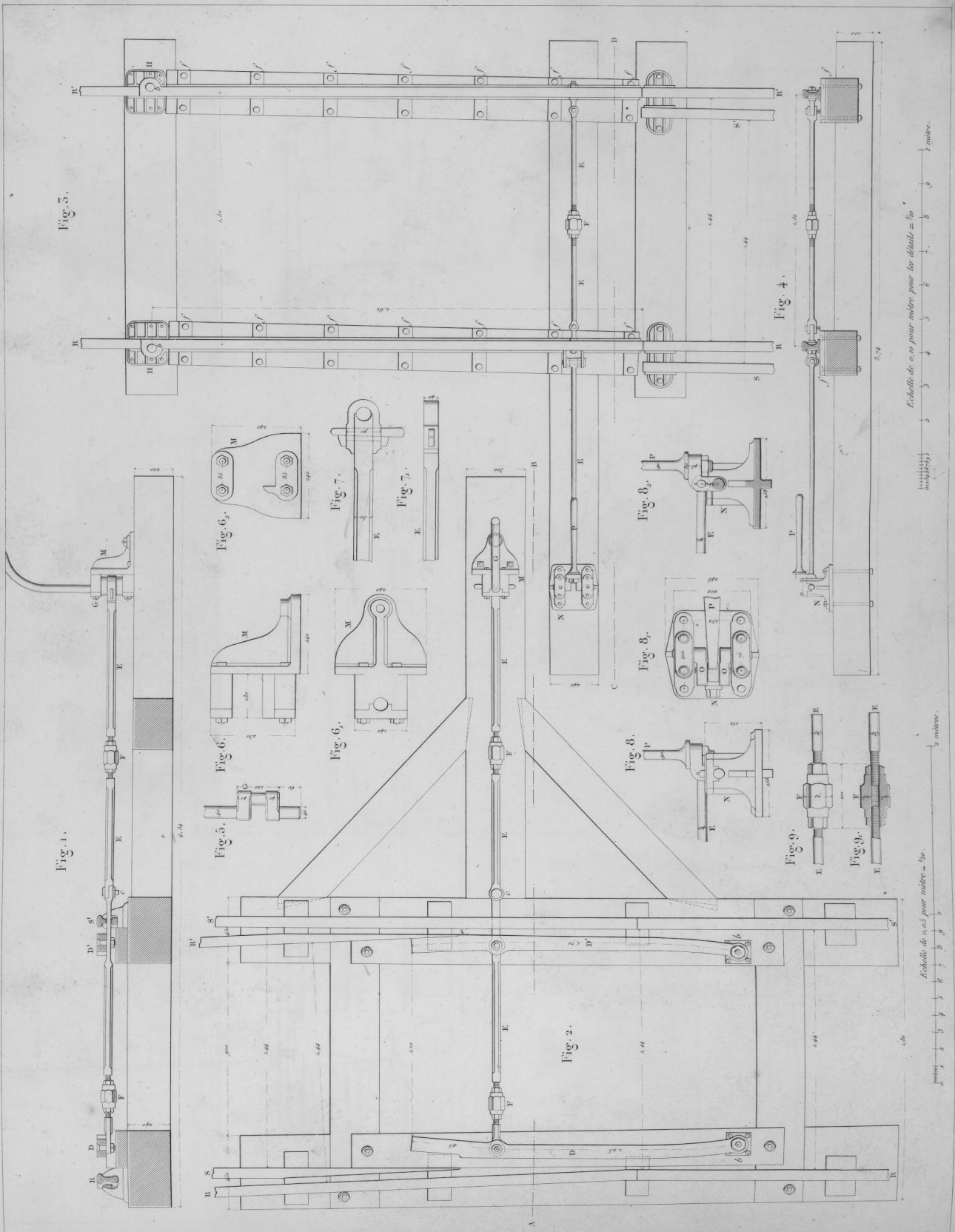

Fig. 1. (H.)

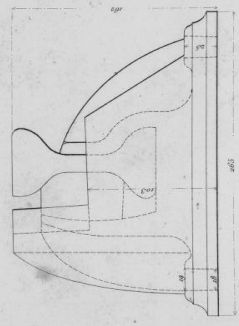

Fig. 2.

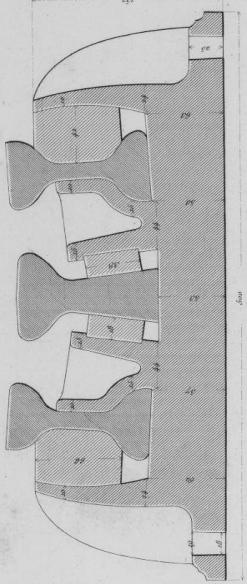

Fig. 3.

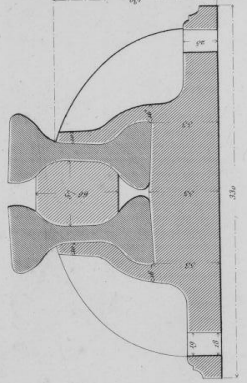

Fig. 1.

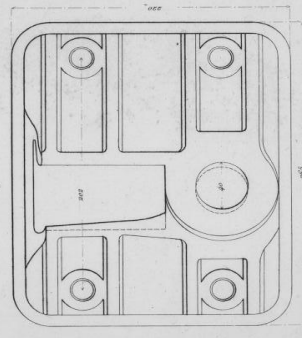

Fig. 2.

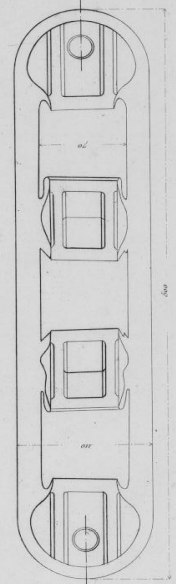

Fig. 3.

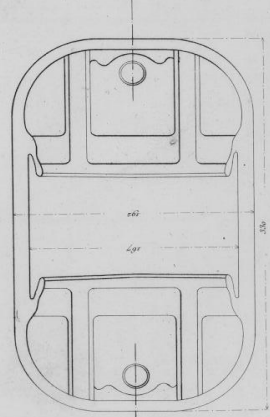

Fig. 4.

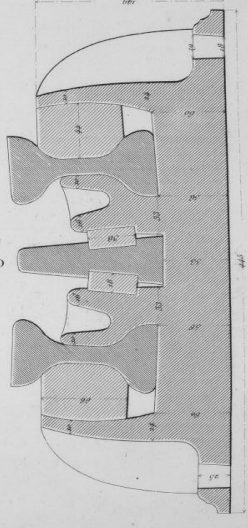

Fig. 5.

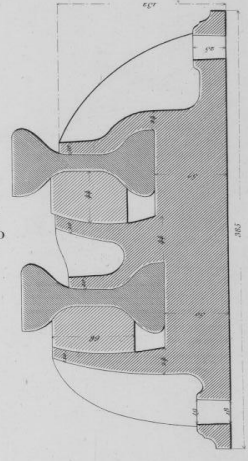

Fig. 6.

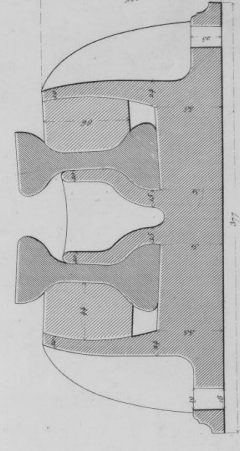

Fig. 4.

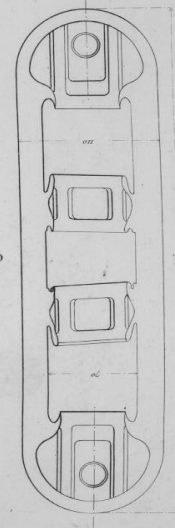

Fig. 5.

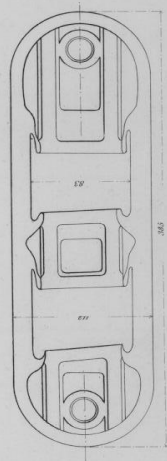
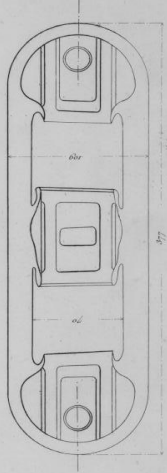

Fig. 6.



0 1 2 3 4 5 6 7 8 9
Echelle de 0,05 pour mètr = 4
4 décimètr.

Fig. 1.

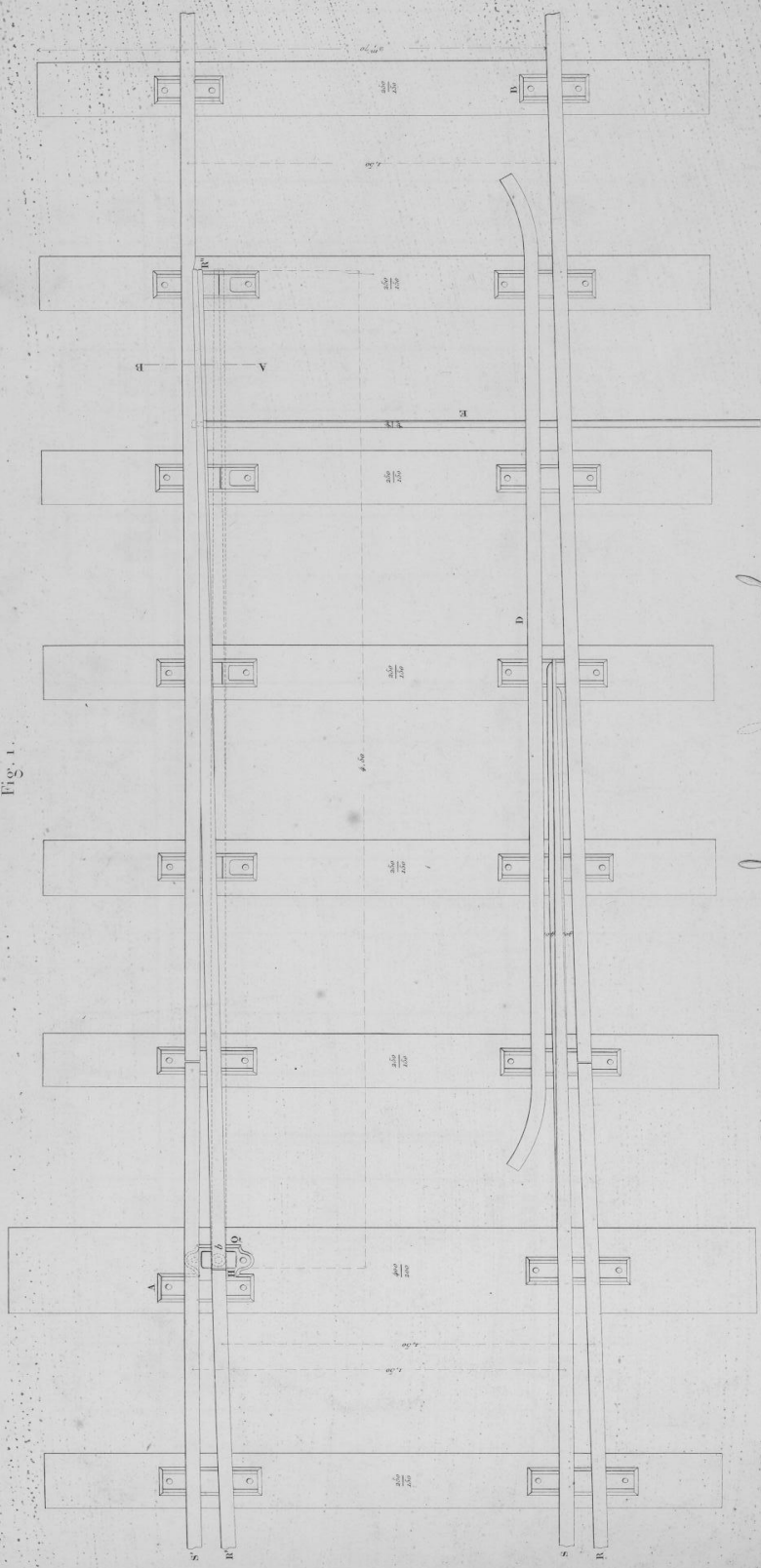

Fig. 5.

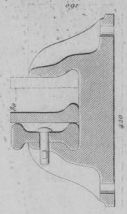

Fig. 5.

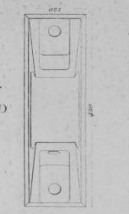

Fig. 4.

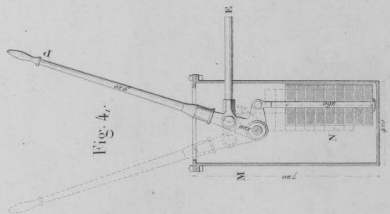

Fig. 4.

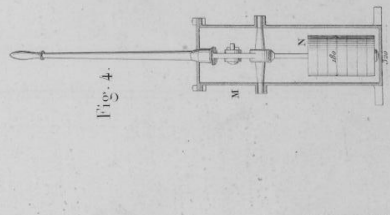

Fig. 5.

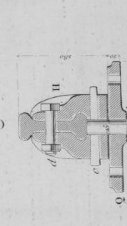

Fig. 5.

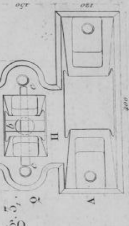

Fig. 2.

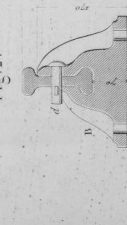
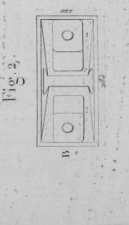

Fig. 2.



Échelle de 0,01 pour les mètres. — Les pour les fig. 1, 2 et 3.

Échelle de 0,01 pour les mètres. — Les pour les fig. 4, 5 et 6.

Échelle de 0,01 pour les mètres. — Les pour les fig. 1, 2 et 3.

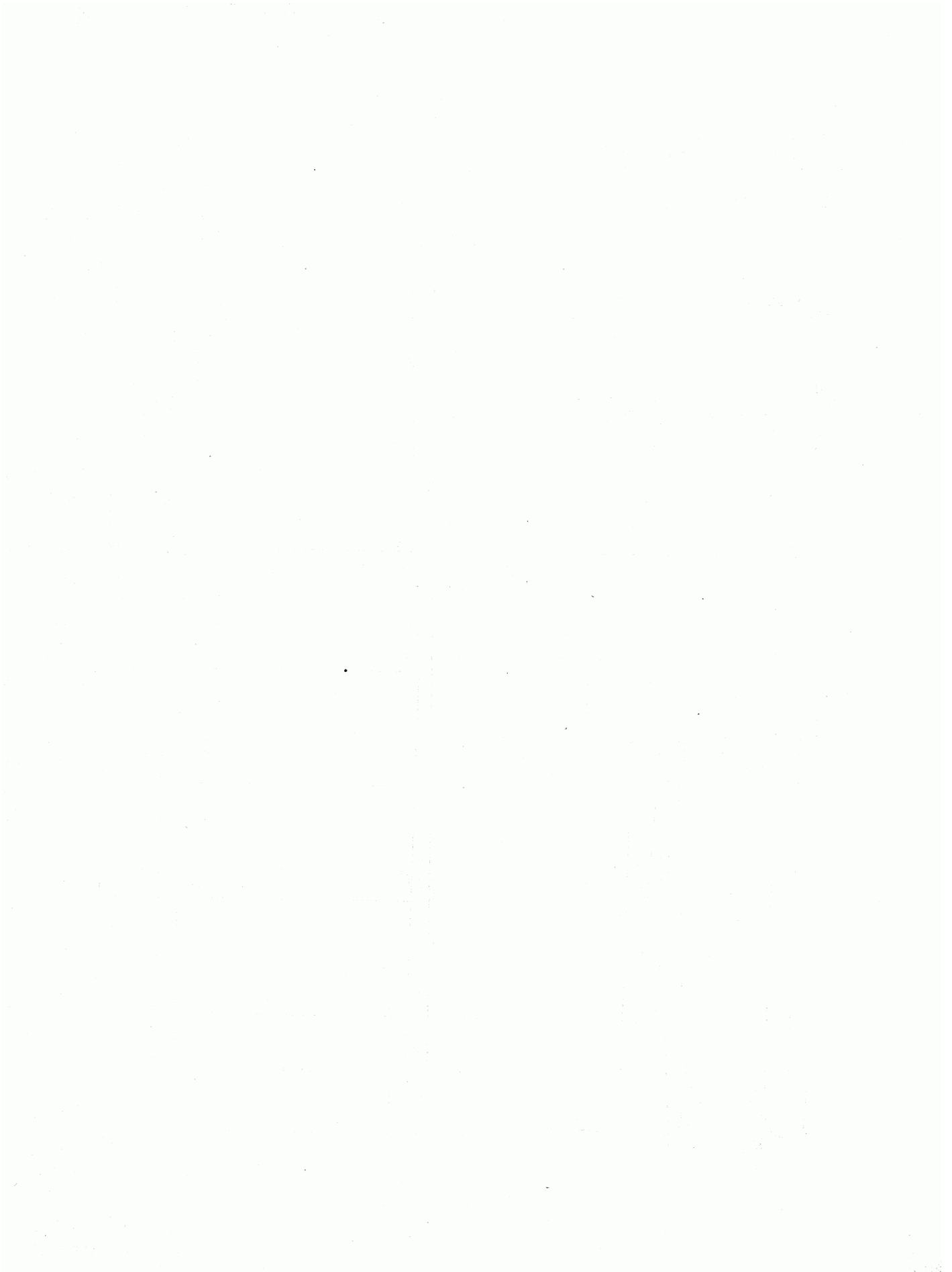

Fig. 1 (H).

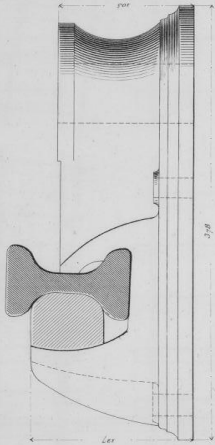

Fig. 1.

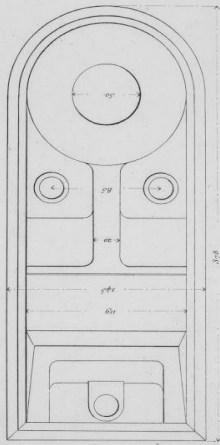

Fig. 2 (K).

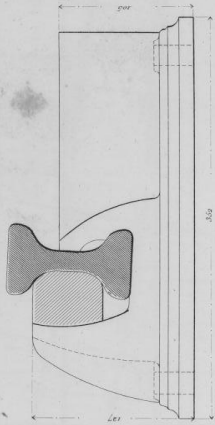

Fig. 2.

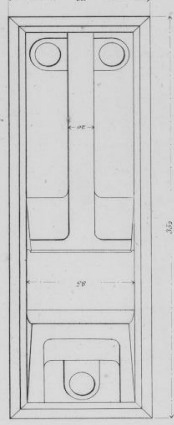

Fig. 3 (D).

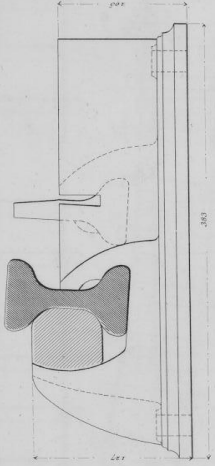

Fig. 3.

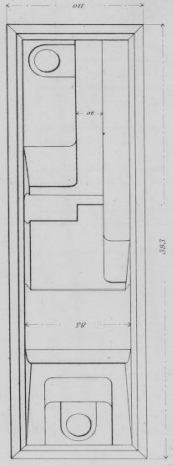

Fig. 4 (L).

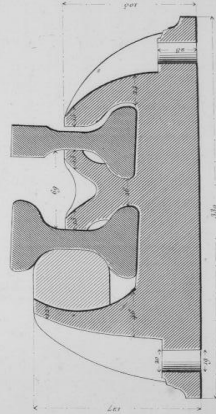

Fig. 4.

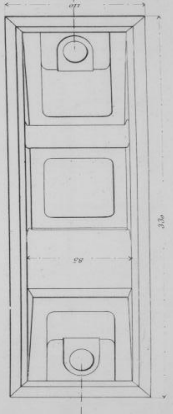

Fig. 5 (O).

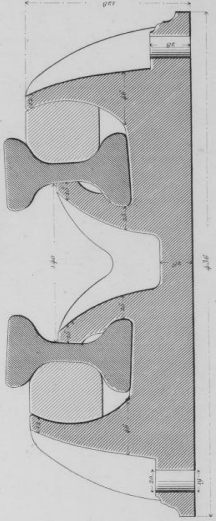

Fig. 5.

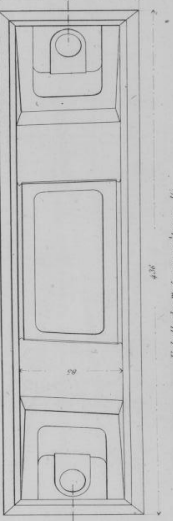

Fig. 6 (M).

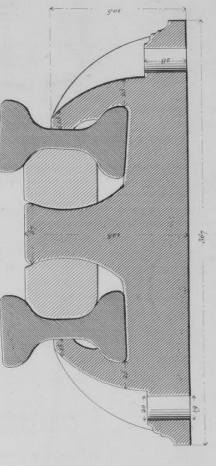
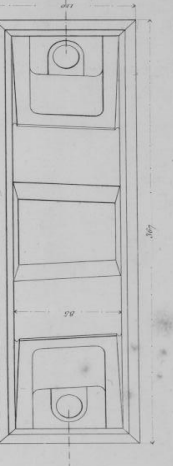
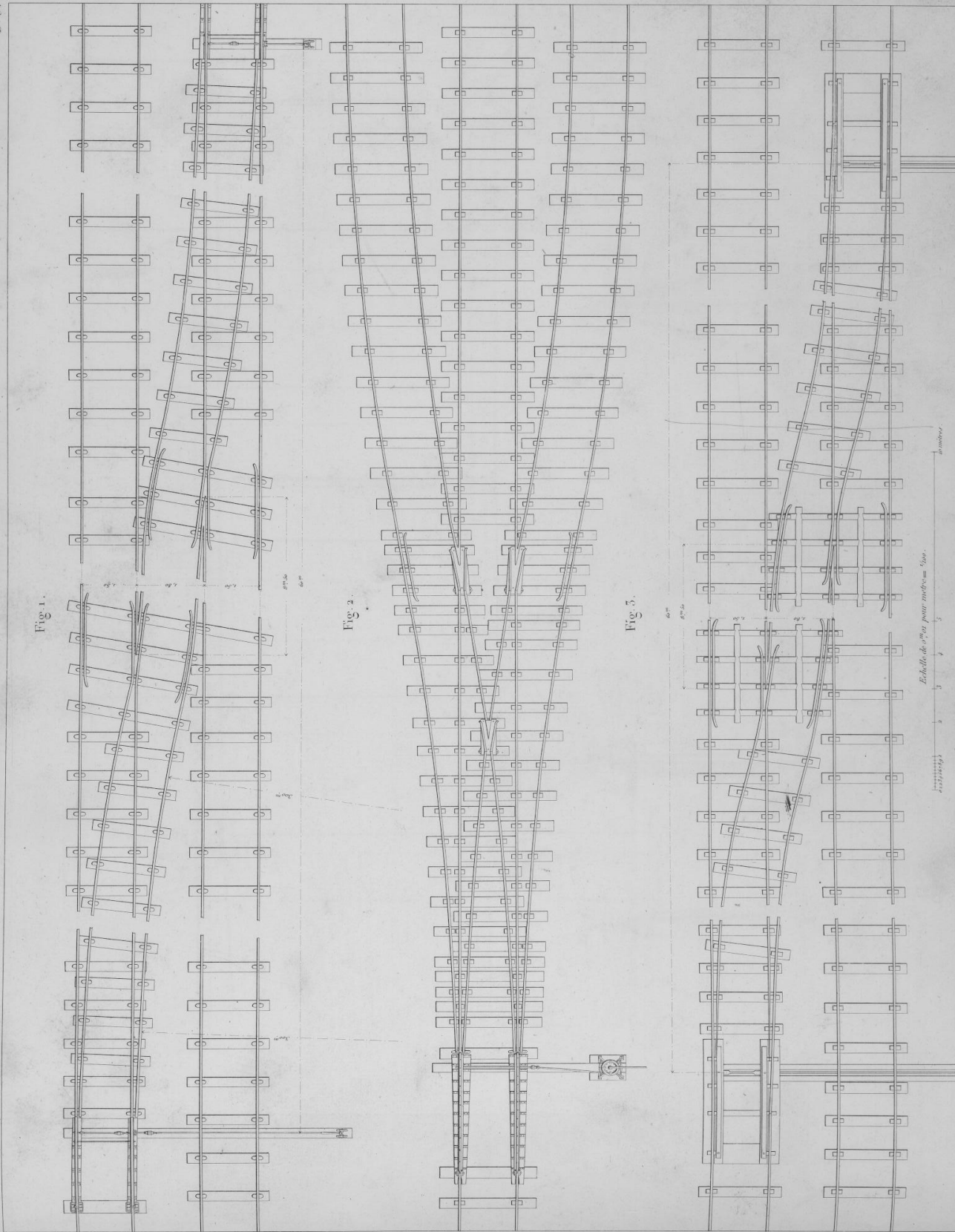

Fig. 6.



1 2 3 4 5 6 7 8 9 10 11 12 13 14 15 16 17 18 19 20 21 22 23 24 25 26 27 28 29 30 31 32 33 34 35 36 37 38 39 40 41 42 43 44 45 46 47 48 49 50 51 52 53 54 55 56 57 58 59 60 61 62 63 64 65 66 67 68 69 70 71 72 73 74 75 76 77 78 79 80 81 82 83 84 85 86 87 88 89 90 91 92 93 94 95 96 97 98 99 100
Echelle de 0^m25 pour metre = 1/4.
Indice.

Ensembles de changements de voies.





Changement de voies pour 5 voies des chemins de fer belges.

D. II.

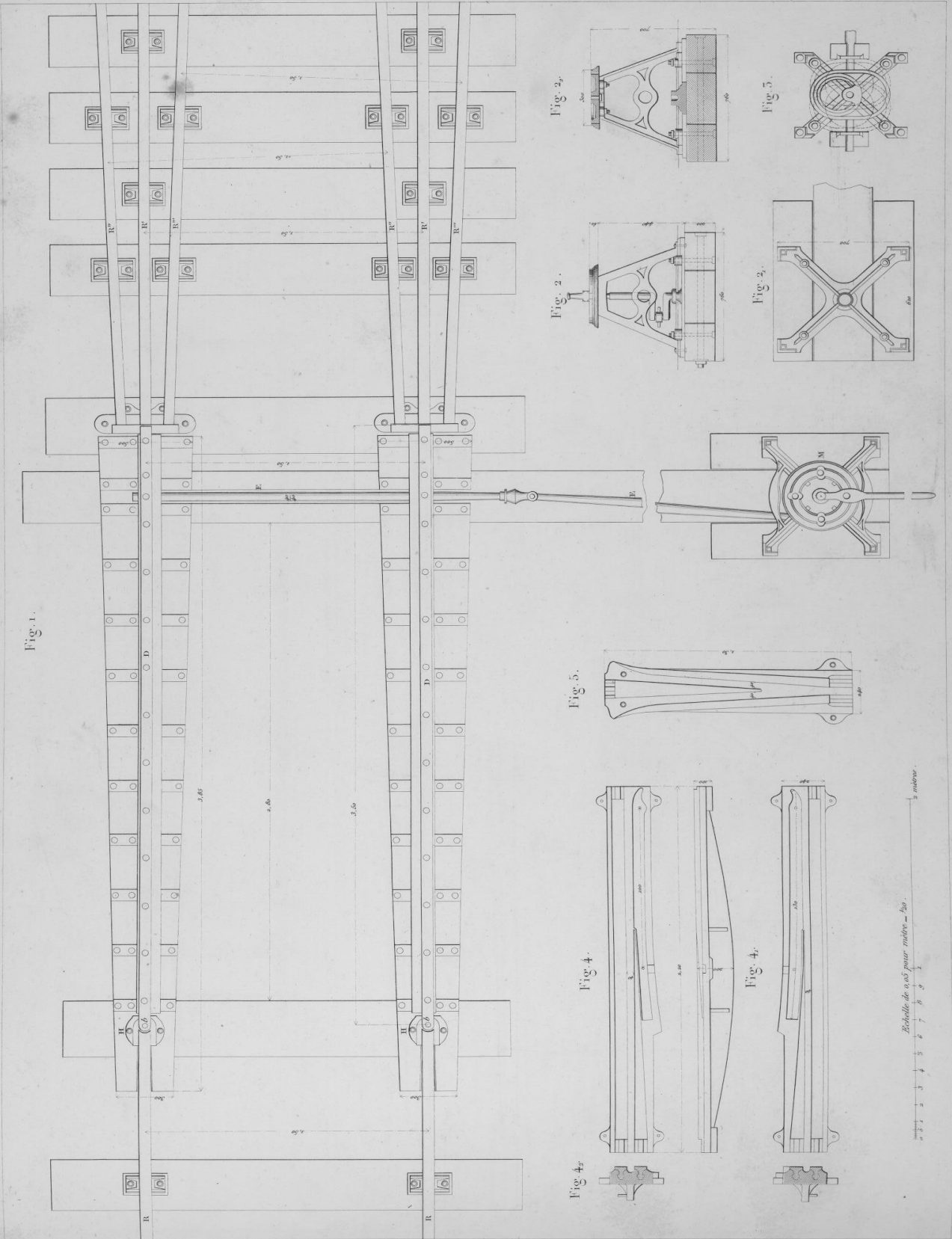

Changement de voies d'Asnières.

Embranchement des chemins de fer de St Germain et Versailles (R.D.).

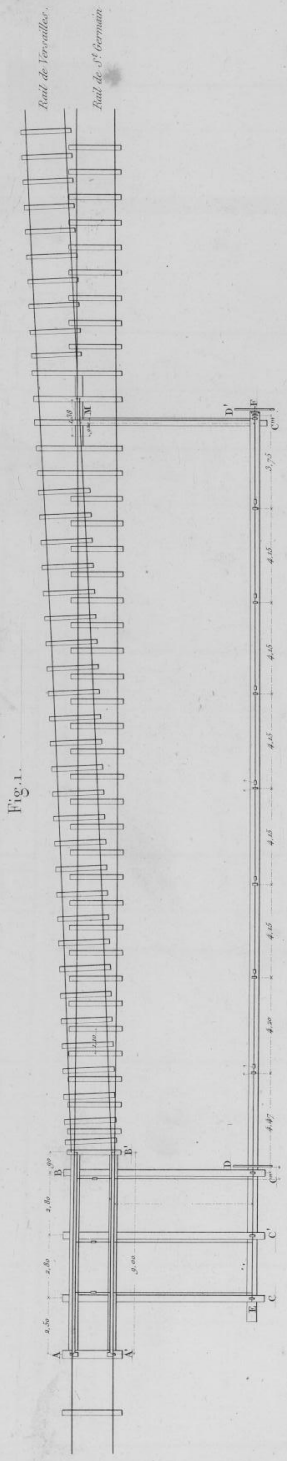

Fig. 1.

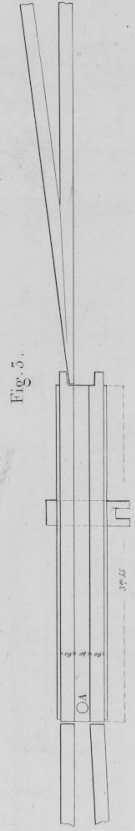

Fig. 5.

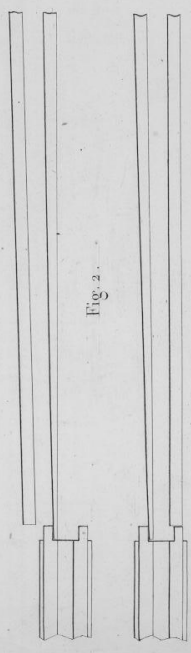

Fig. 2.

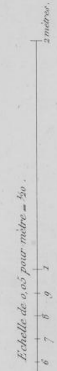

Fig. 4.

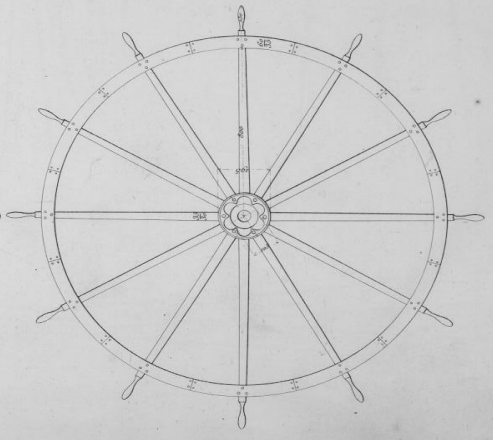
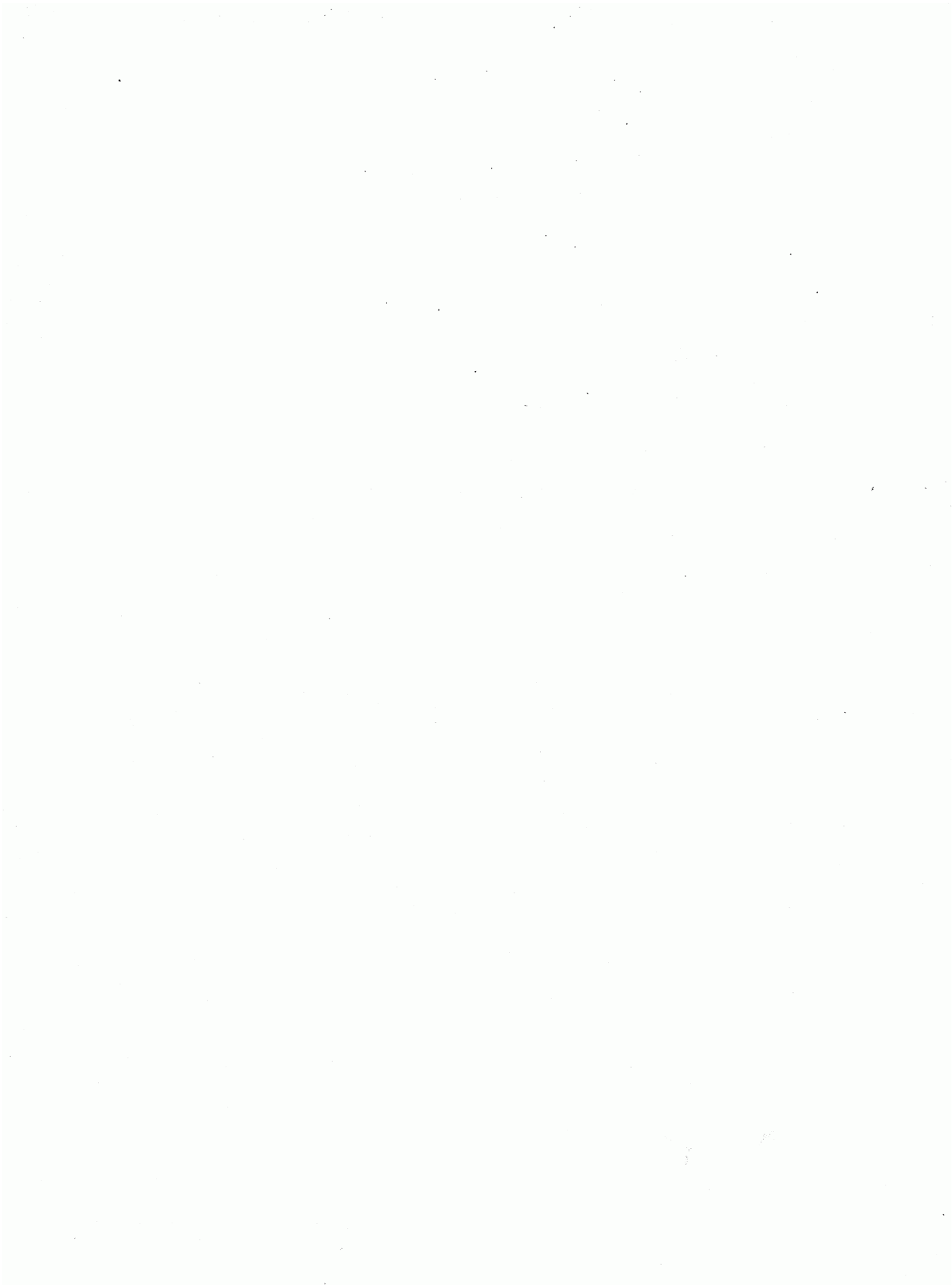

Fig. 5.



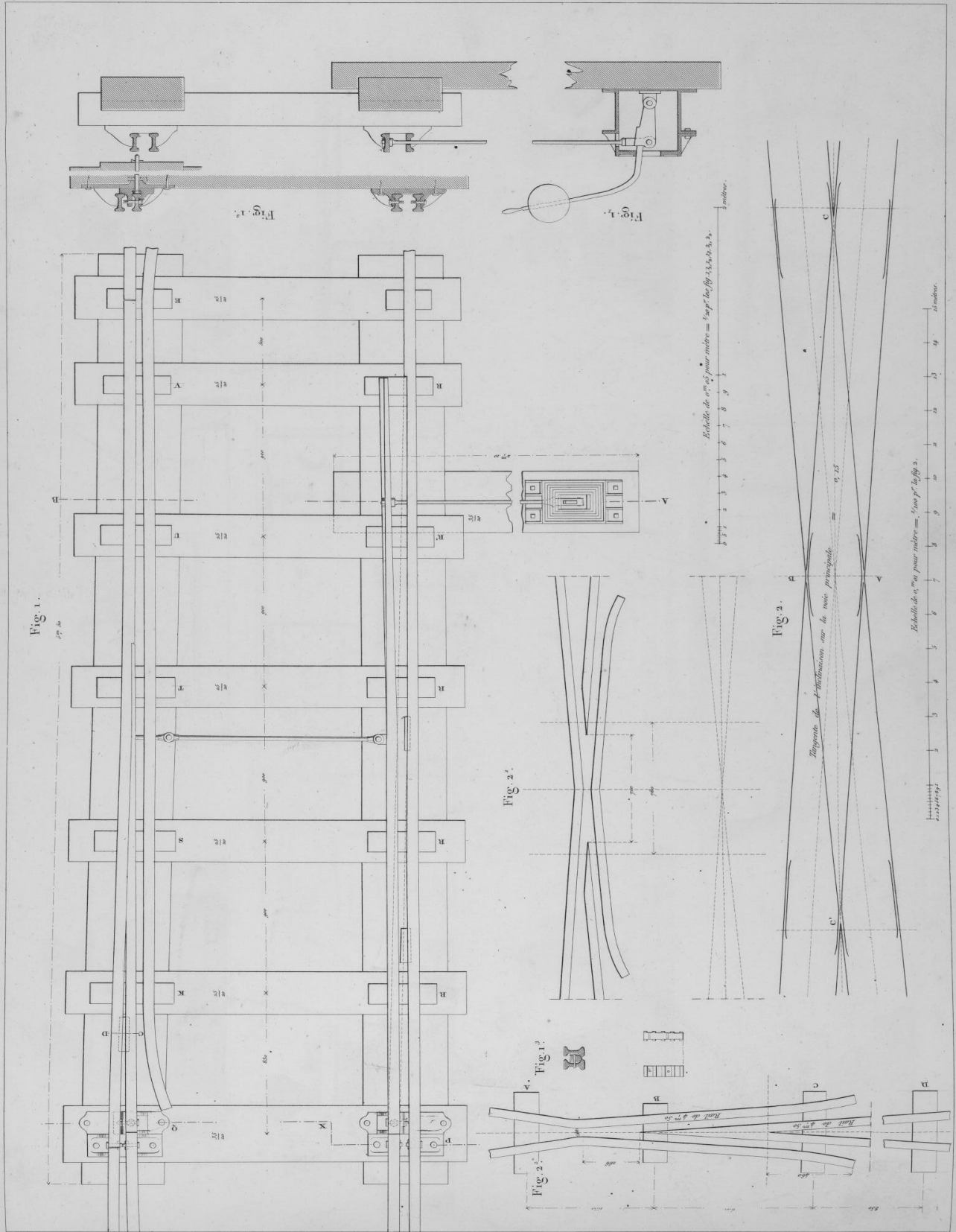

Fig. 1^a.

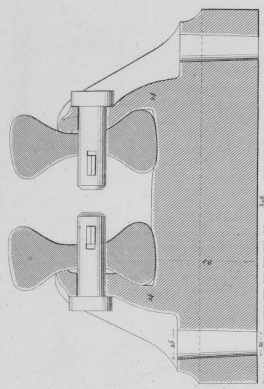

Fig. 1^b.

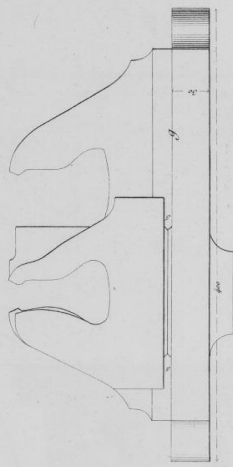

Fig. 1^c.

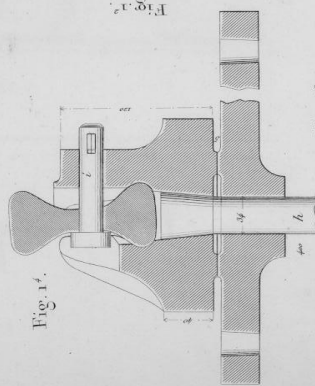

Fig. 1^d.

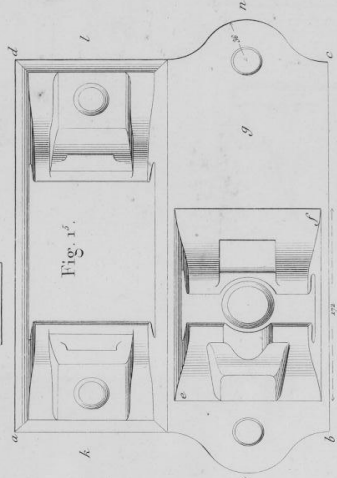

Fig. 2^a.

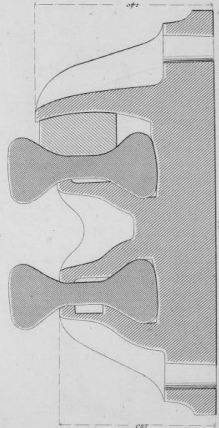

Fig. 2^b.

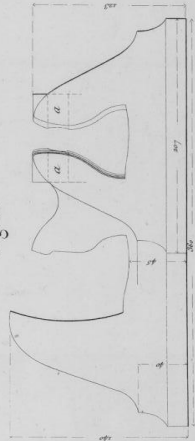

Fig. 2^c.

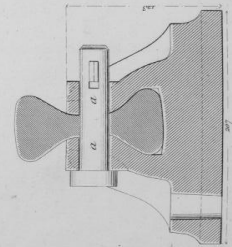

Fig. 2^d.

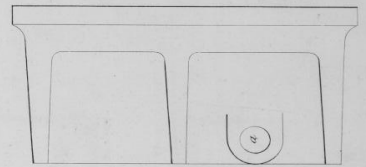

Fig. 2^e.

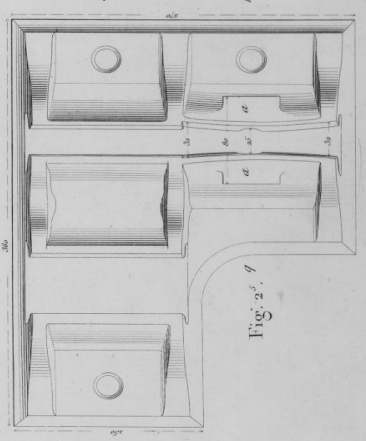

Fig. 3^a.

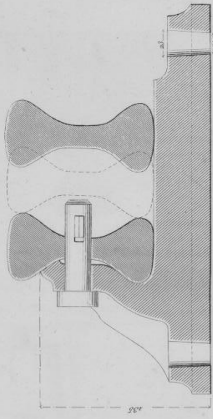

Fig. 3^b.

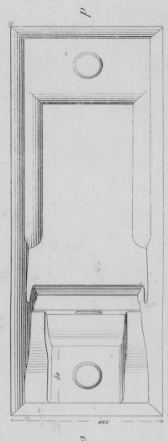

Fig. 4.

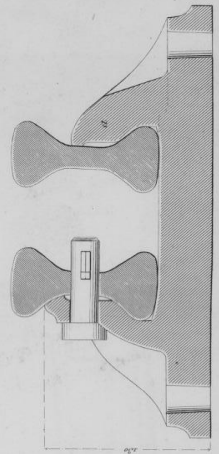
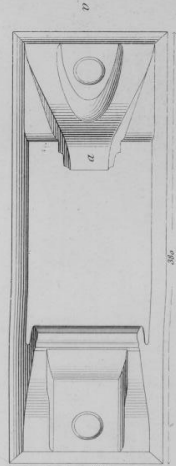

Fig. 4^a.



Échelle de 0,25 pour mètre = 1/4.

0 1 2 3 4 5 6 7 8 9 10

centimètres.

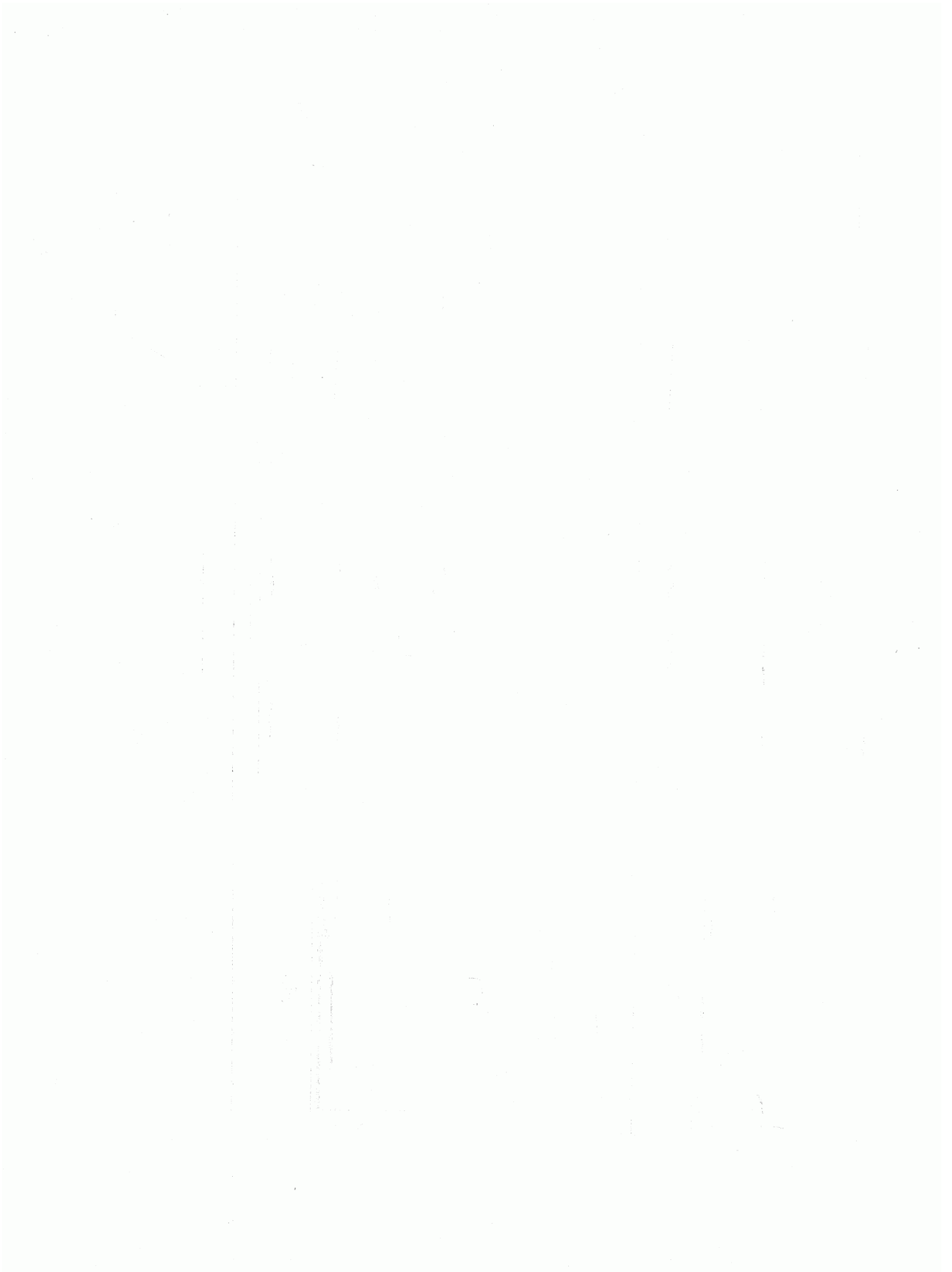

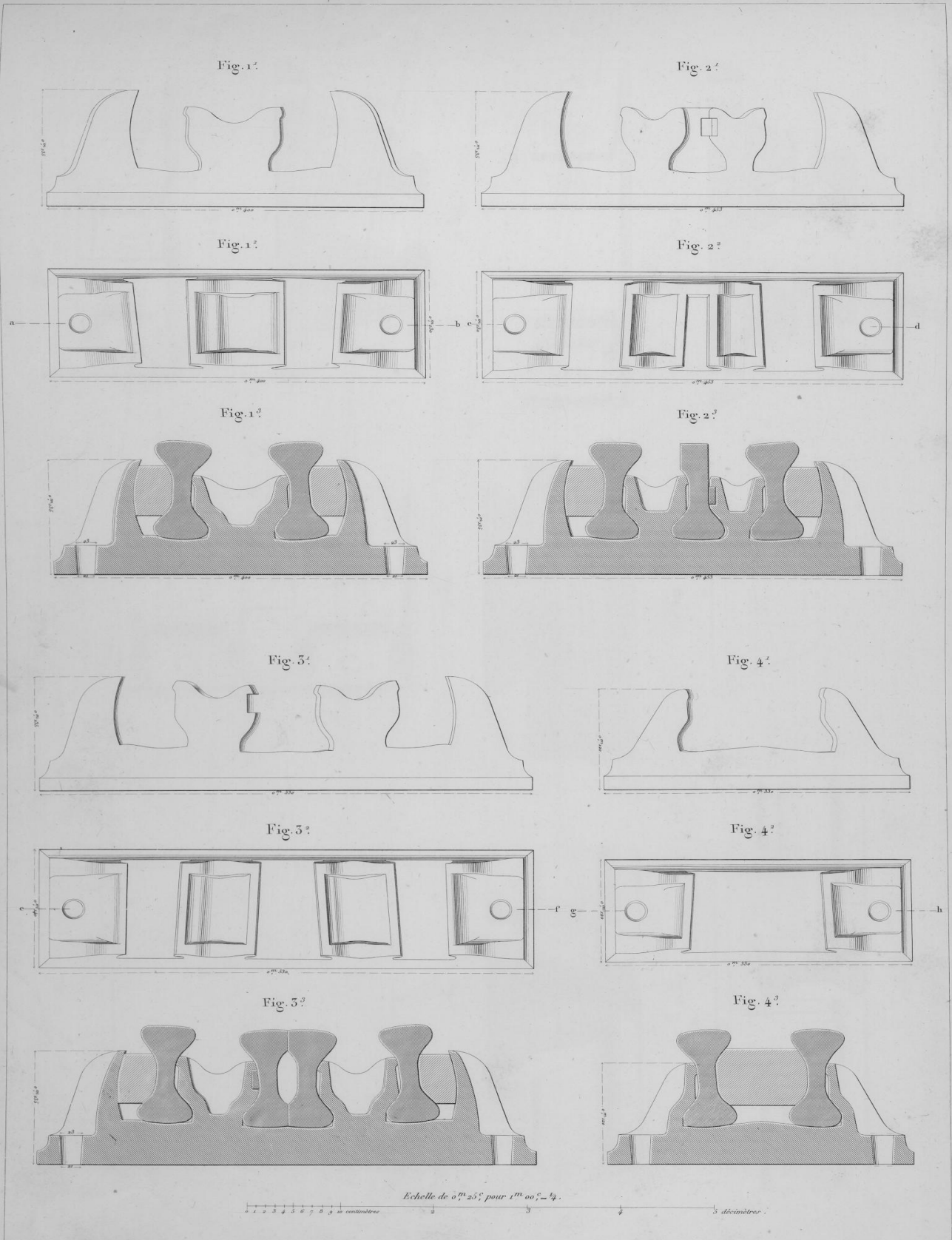

Fig. 1^r.

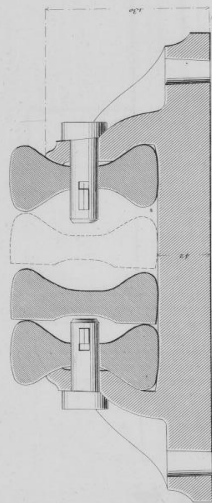

Fig. 2^r.

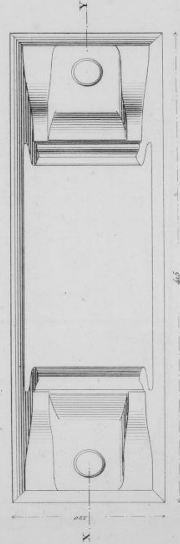

Fig. 3^r.

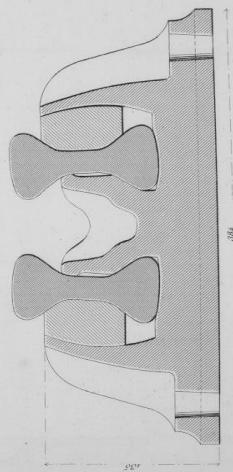

Fig. 4^r.

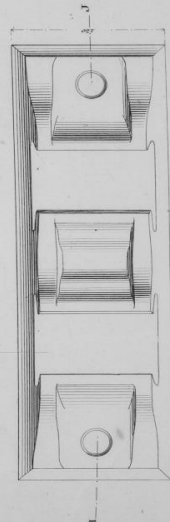

Fig. 5^r.

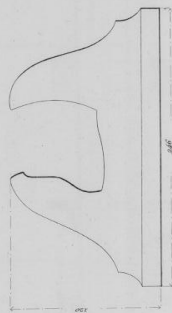

Fig. 6^r.

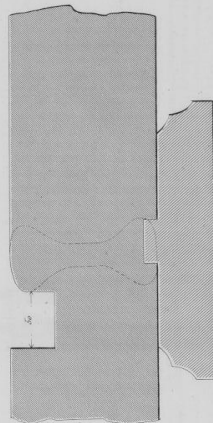
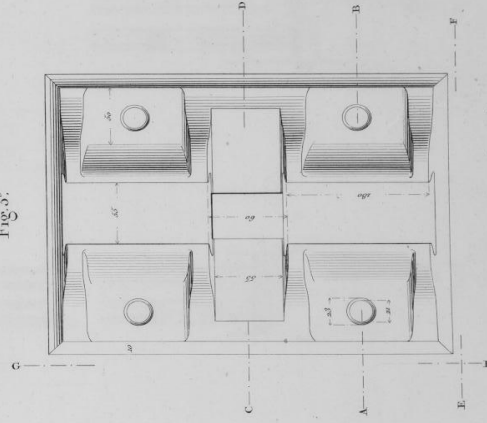

Fig. 7^r.



Echelle de 0^m,5 pour mètre = 1/4.

Echelle de 0^m,5 pour mètre = 1/20.

Fig. 8^r.

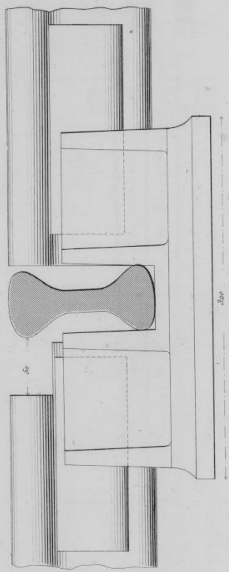

Fig. 9^r.

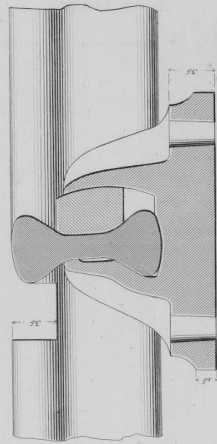

Fig. 10^r.

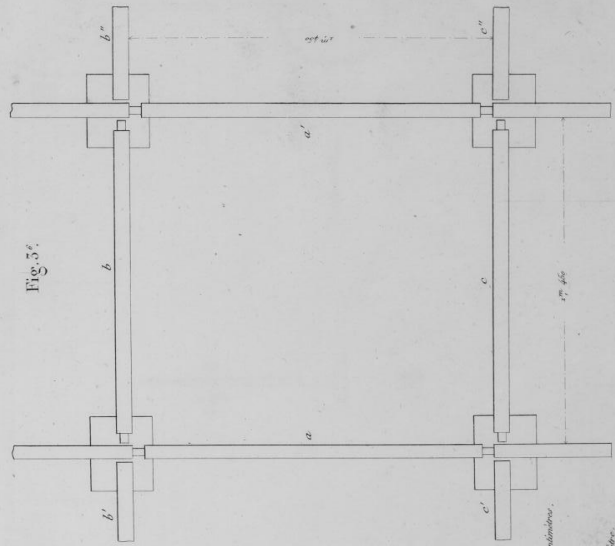

Fig. 1.

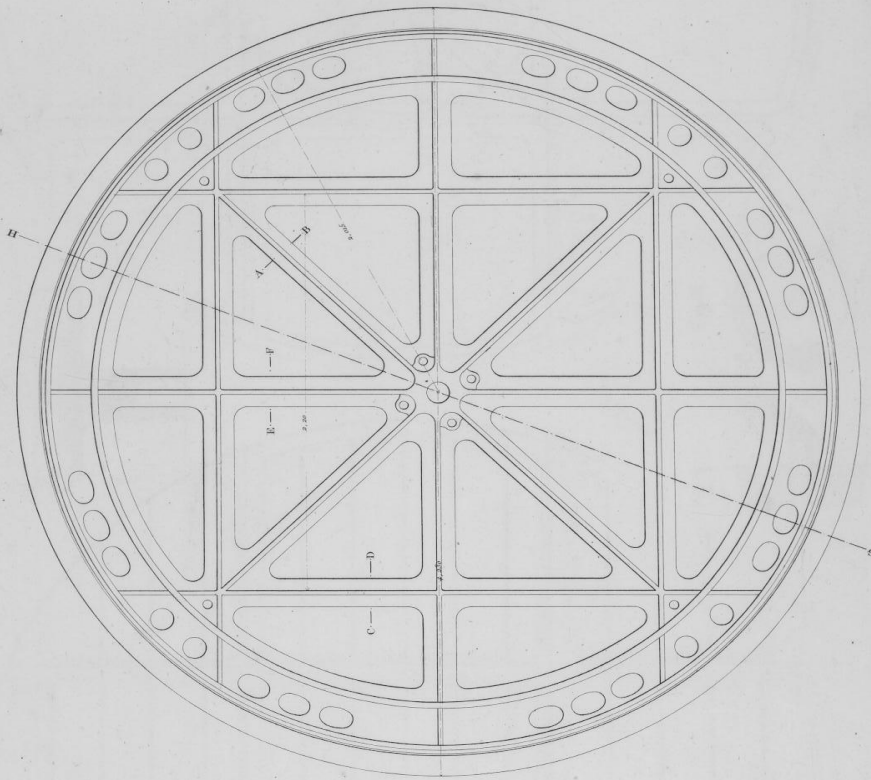

Fig. 5.

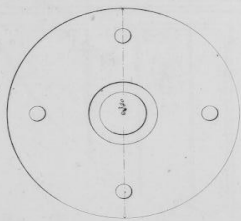

Fig. 5.

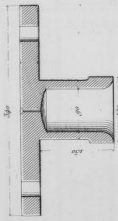

Fig. 4.

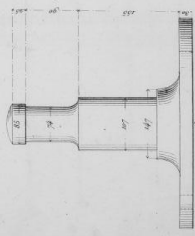
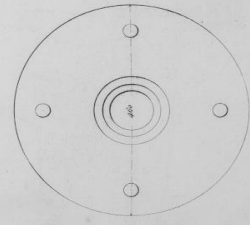

Fig. 4.



Echelle de 0,01 pour mètre = 55.

1/2 mètre

Fig. 6.

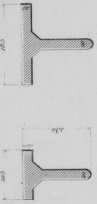

Fig. 8.

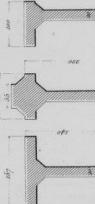

Fig. 9.

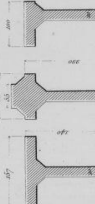

Fig. 10.

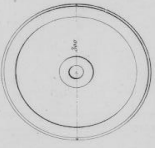

Fig. 10.

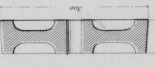

Fig. 11.



Fig. 11.

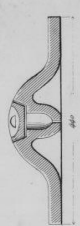

Fig. 13.

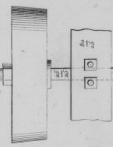

Fig. 13.

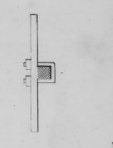
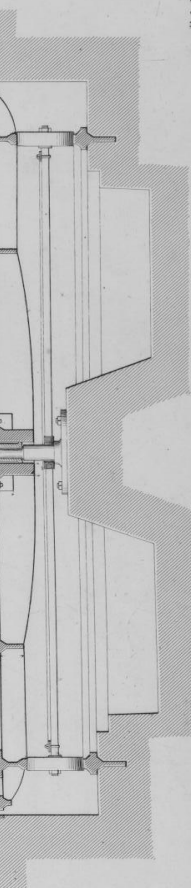

Fig. 2.



Echelle de 0,01 pour mètre pour les détails.

1/2 mètre

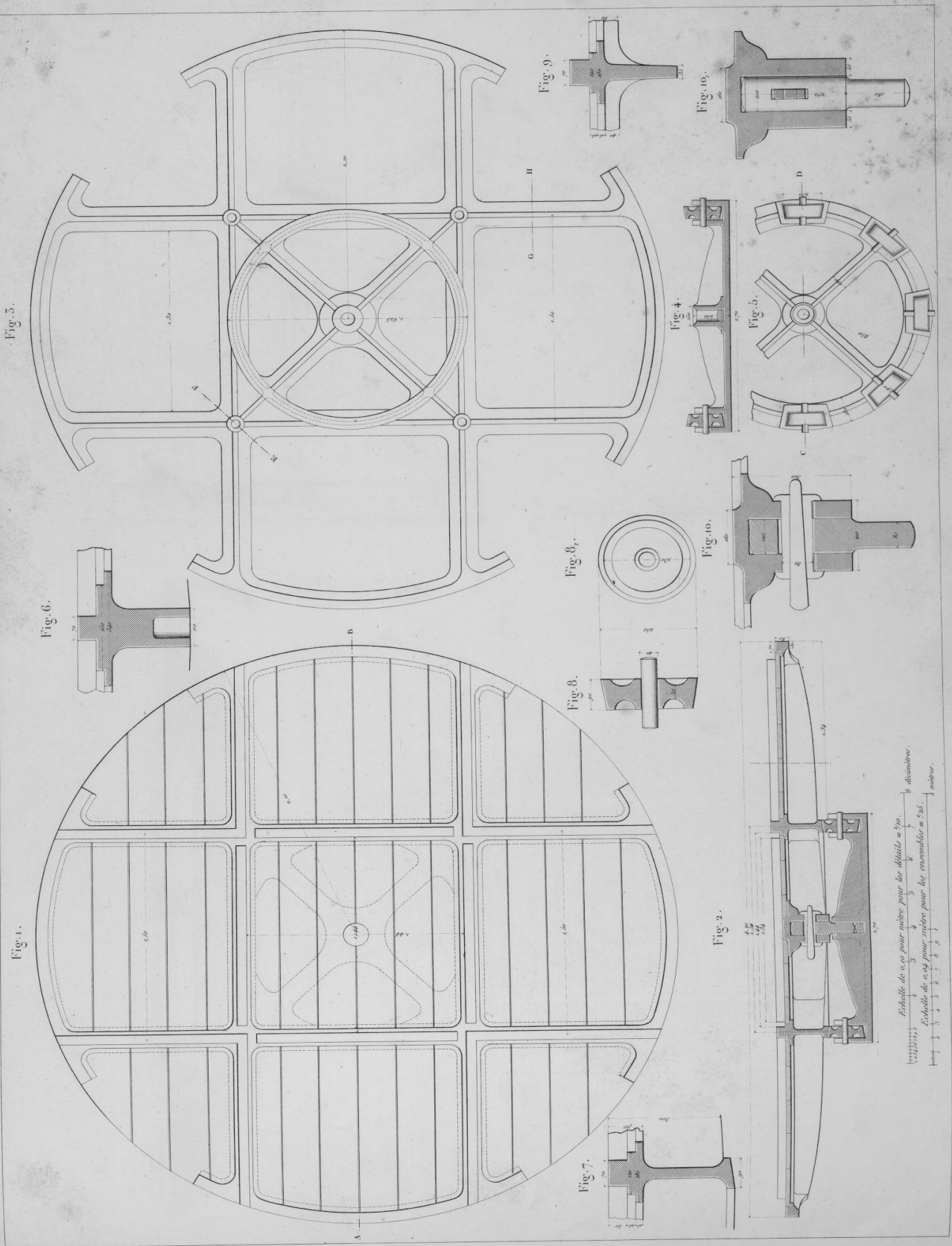

Fig. 1.

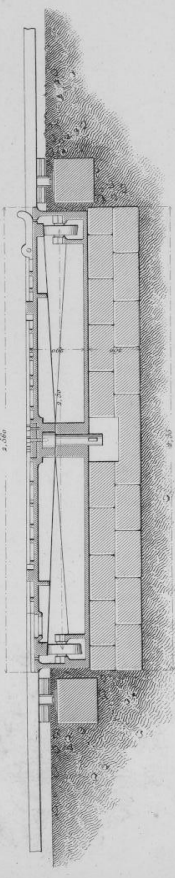

Fig. 2.

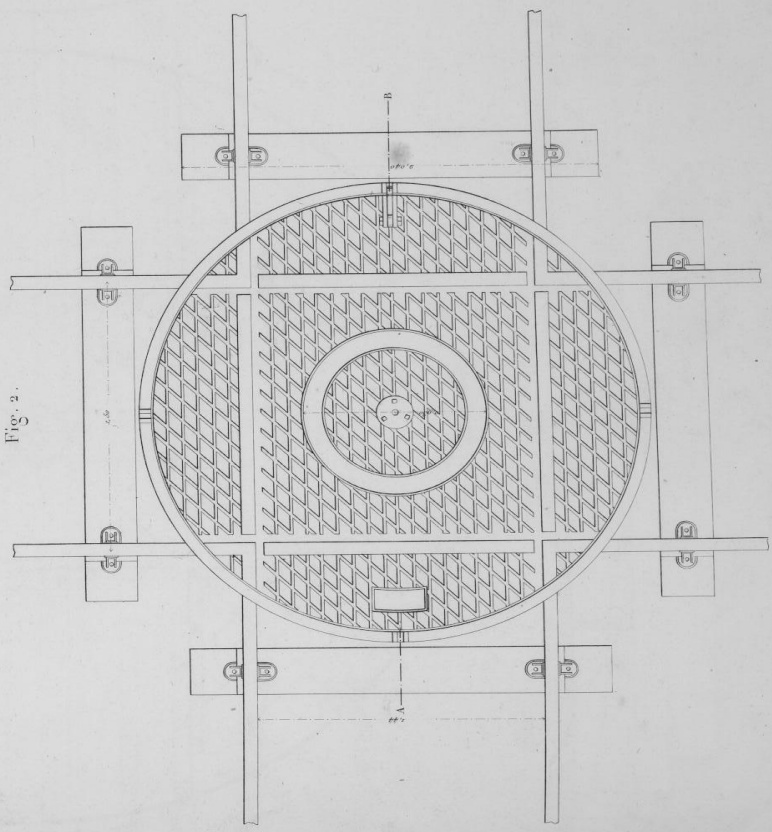

Fig. 3.

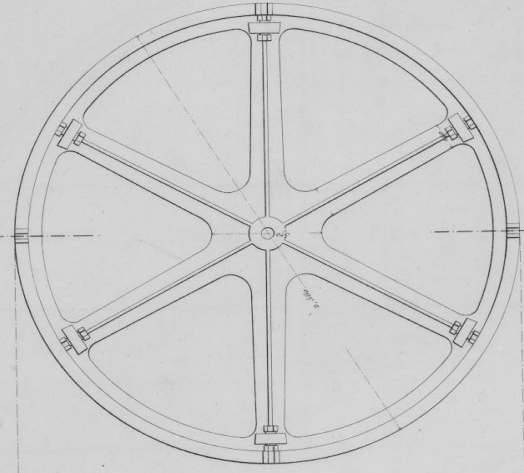

Fig. 5.

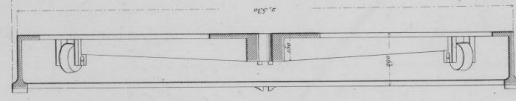

Fig. 4.

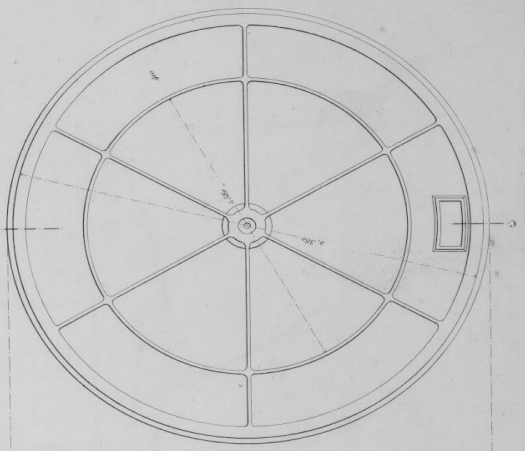
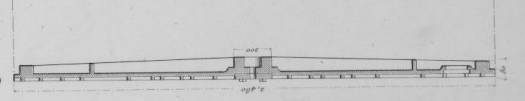
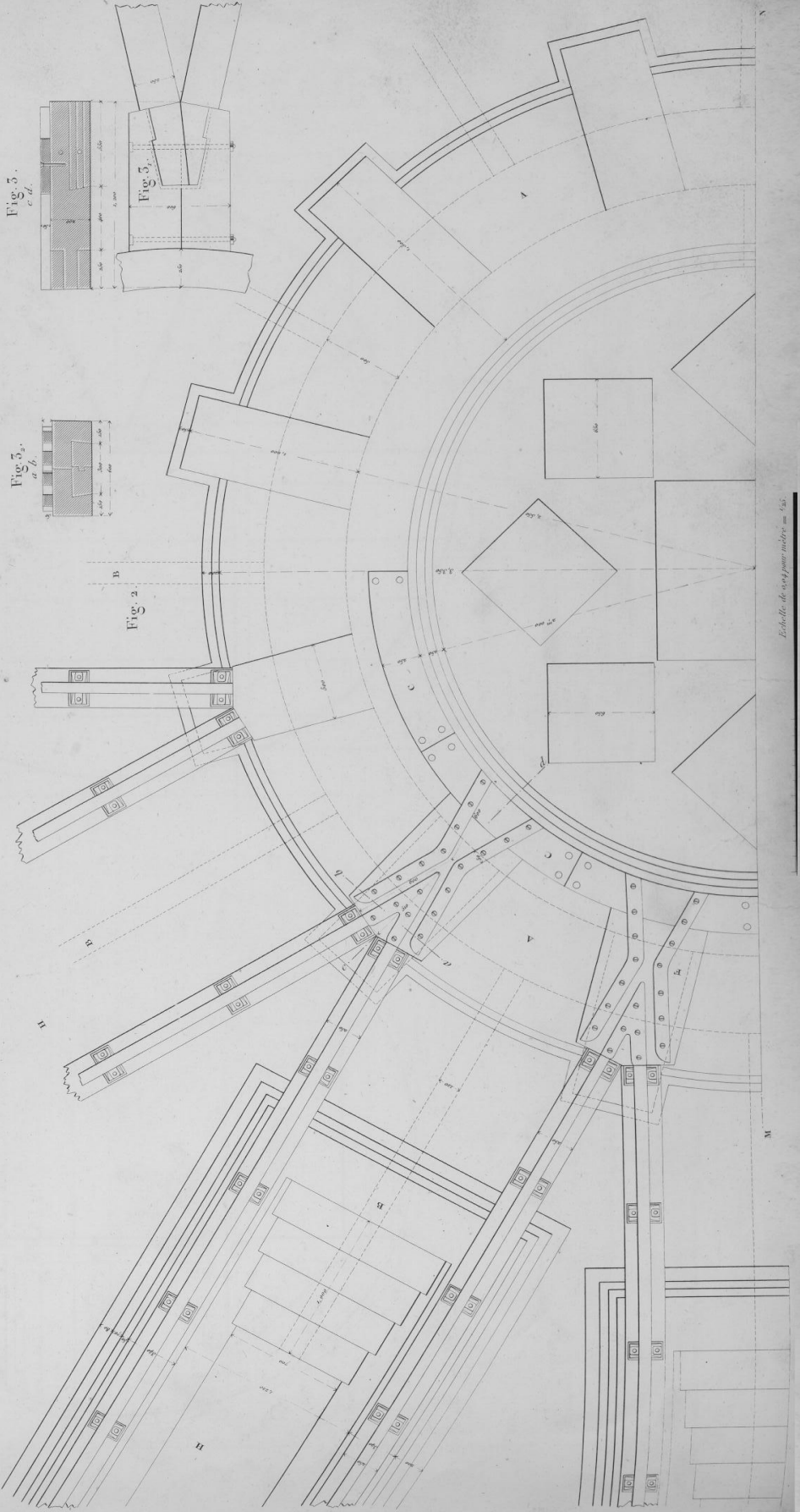
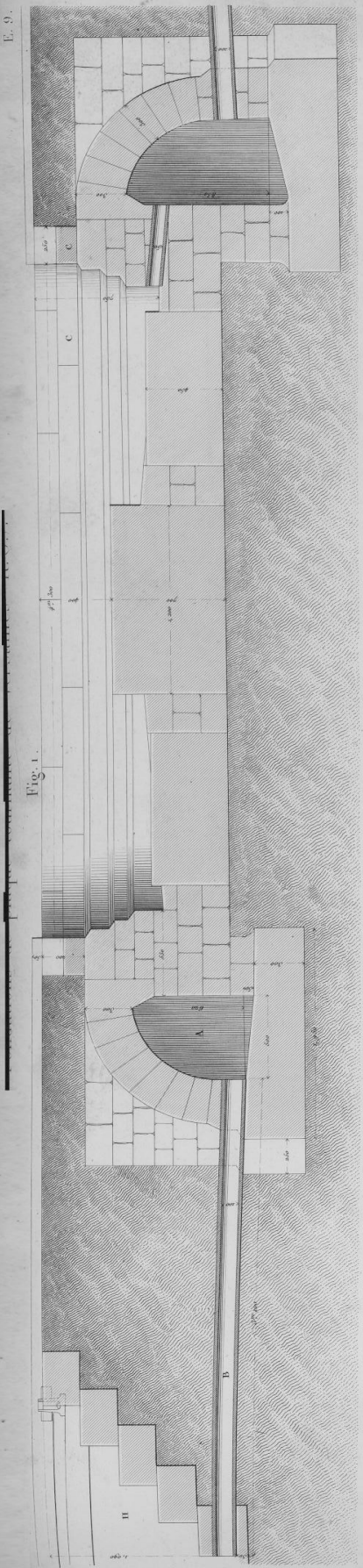

Fig. 4.









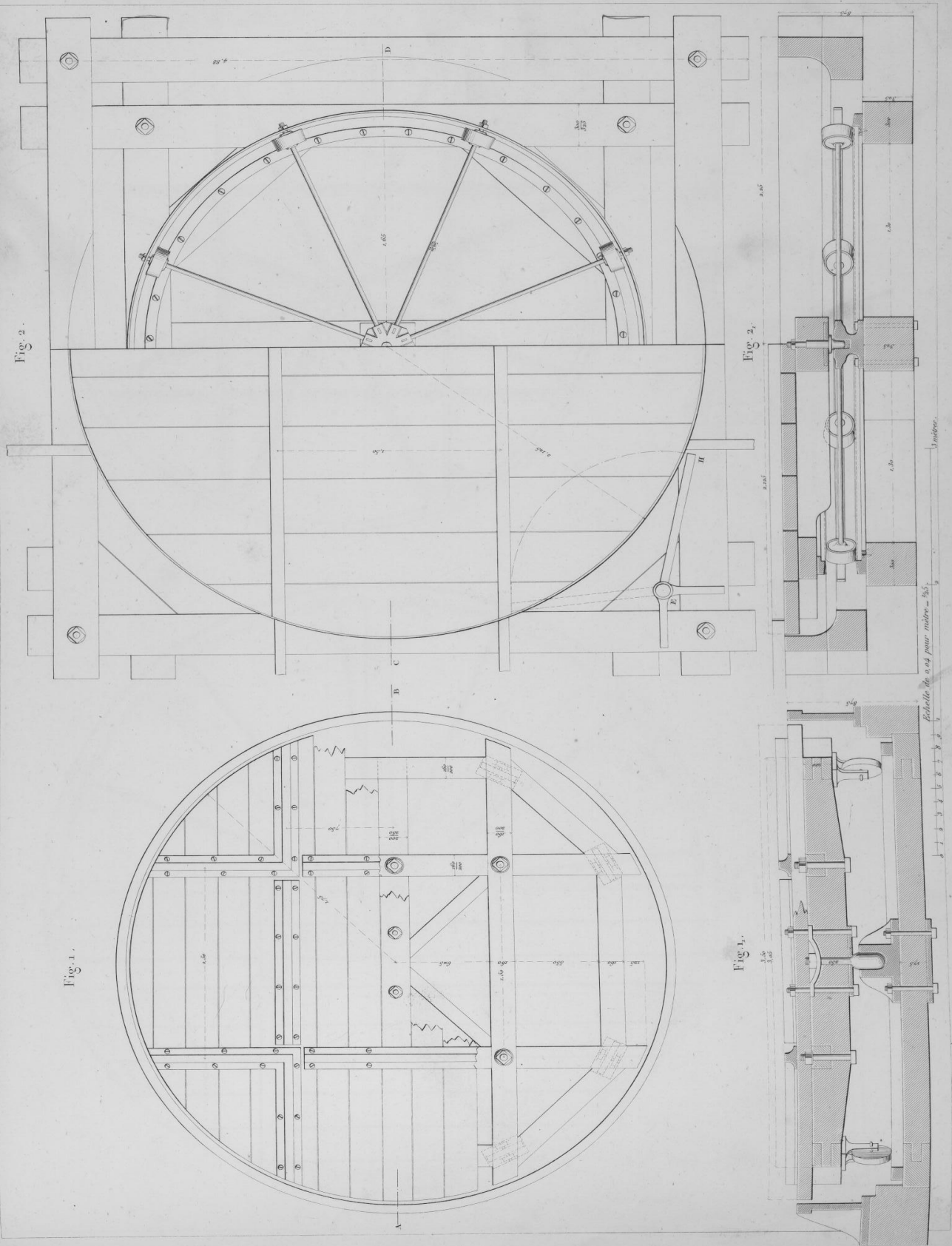

Plaques tournantes en fonte des chemins du Gard et de Liverpool.

Fig. 1.

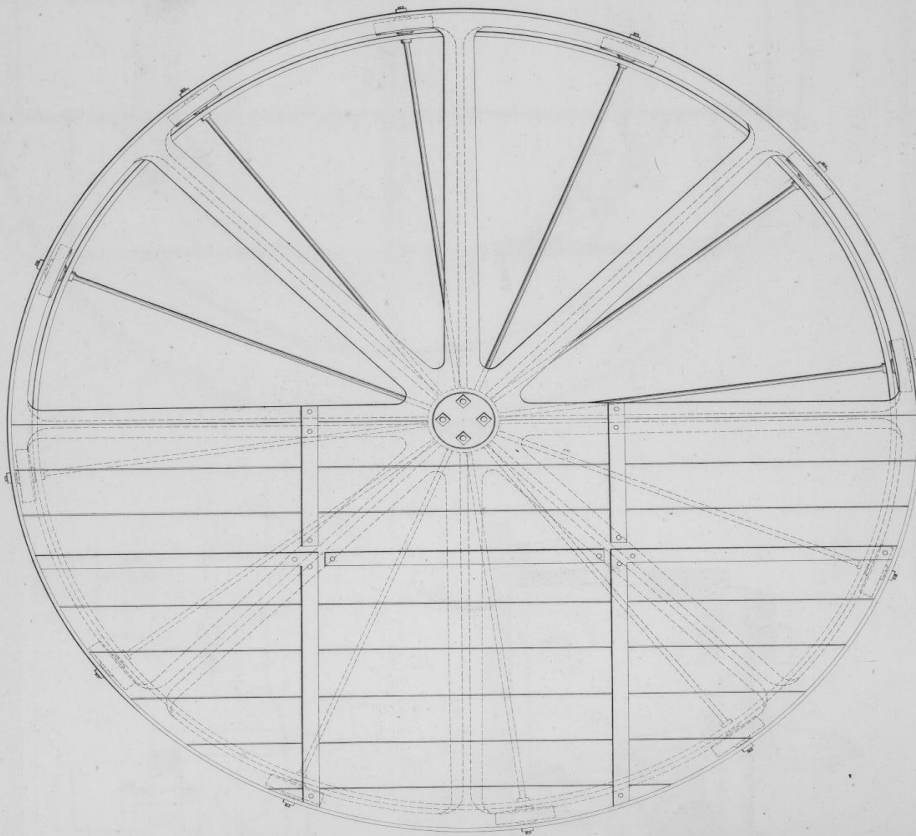

Fig. 2.

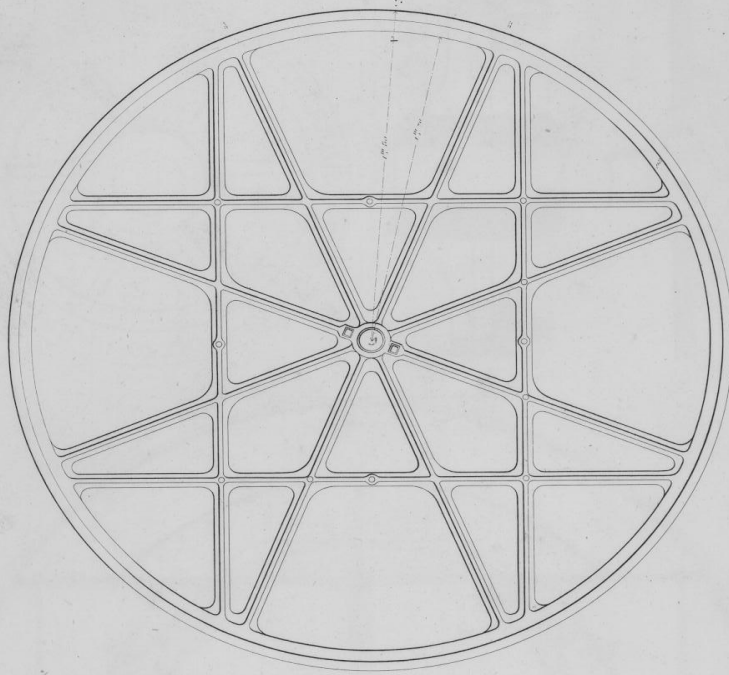

Fig. 1₂.

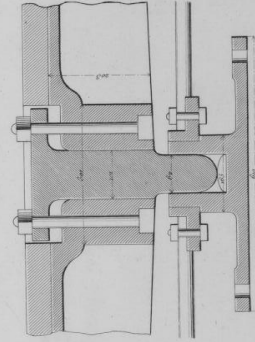

Fig. 2.

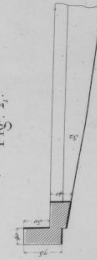
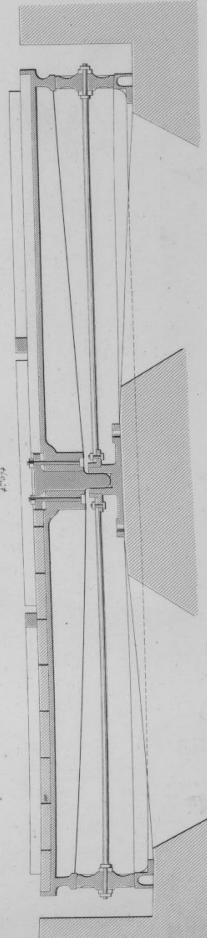

Fig. 2₂.



Fig. 1₂.



Echelle de 1/20 pour les parties en fonte et de 1/10 pour les parties en fer.

Echelle de 1/20 pour les parties en fonte et de 1/10 pour les parties en fer.

Echelle de 1/20 pour les parties en fonte et de 1/10 pour les parties en fer.

Plaque tournante pour locomotive et tender.

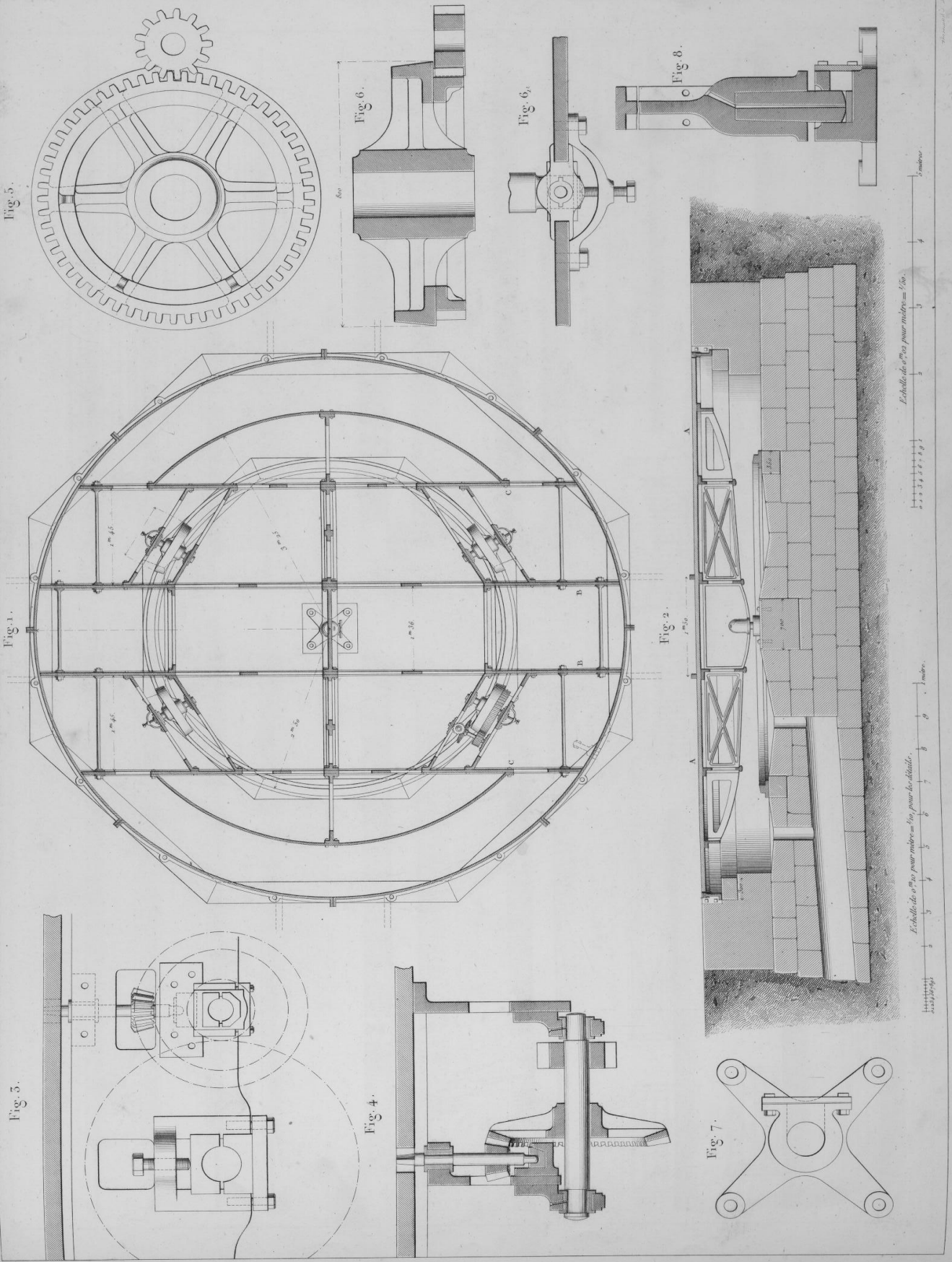

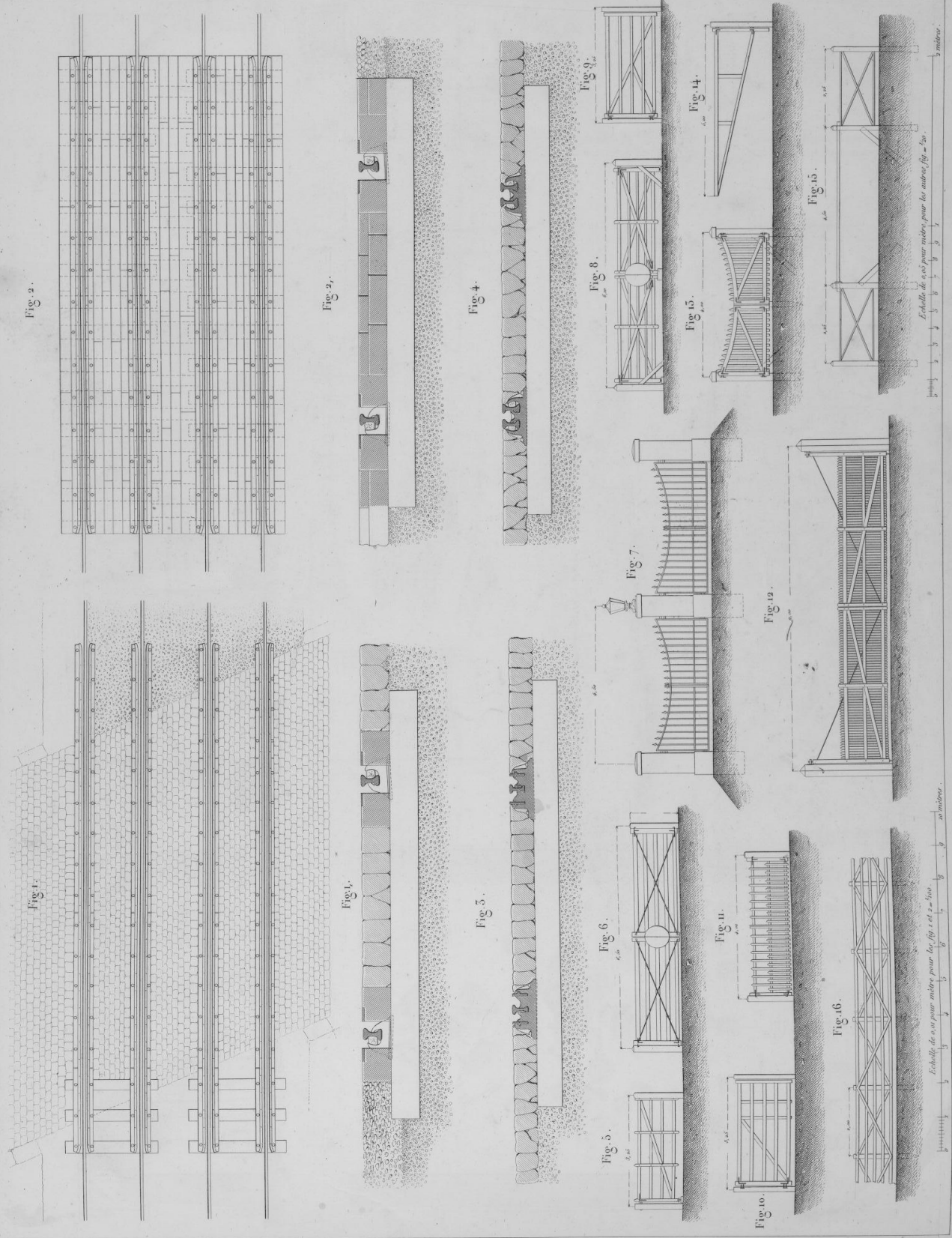

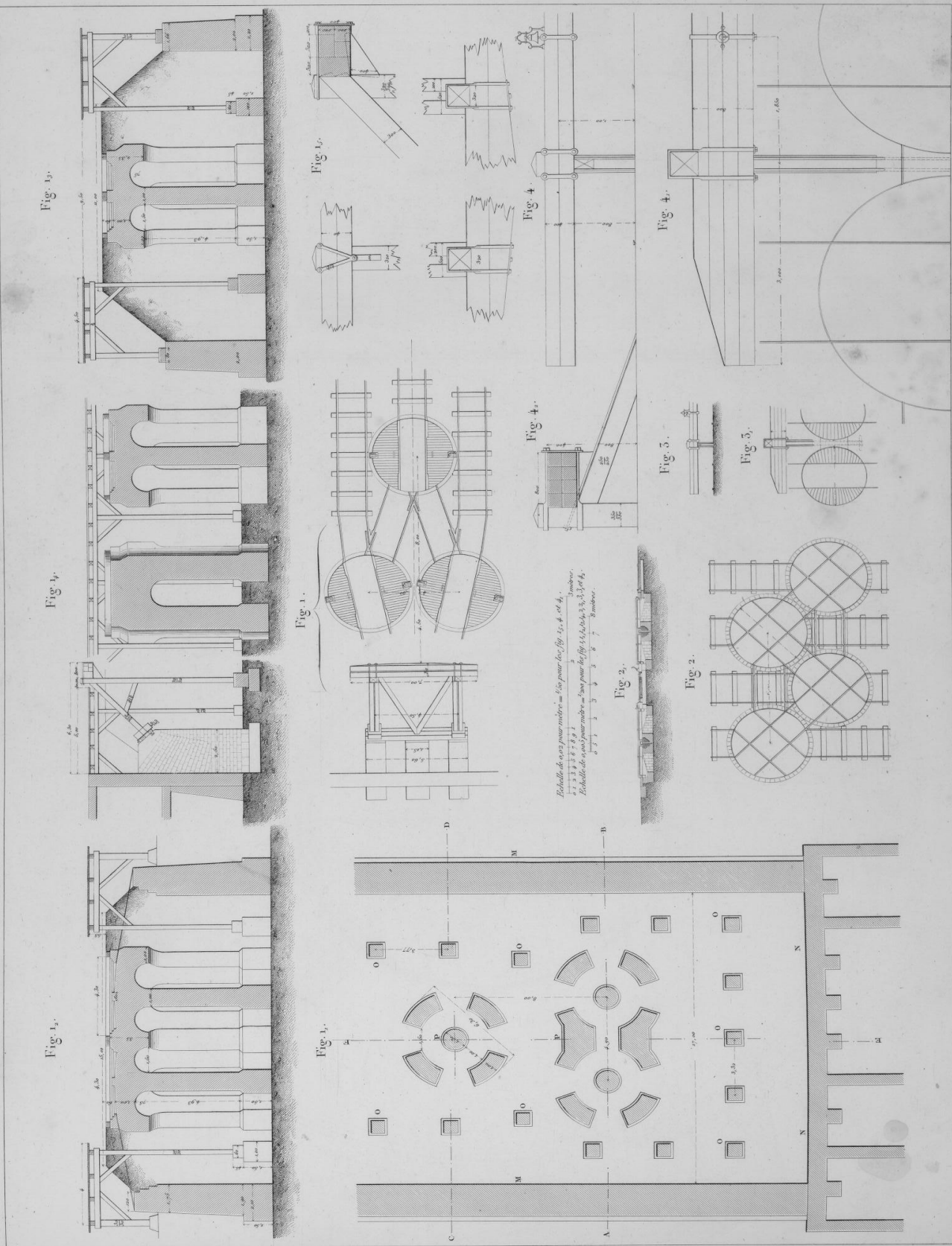

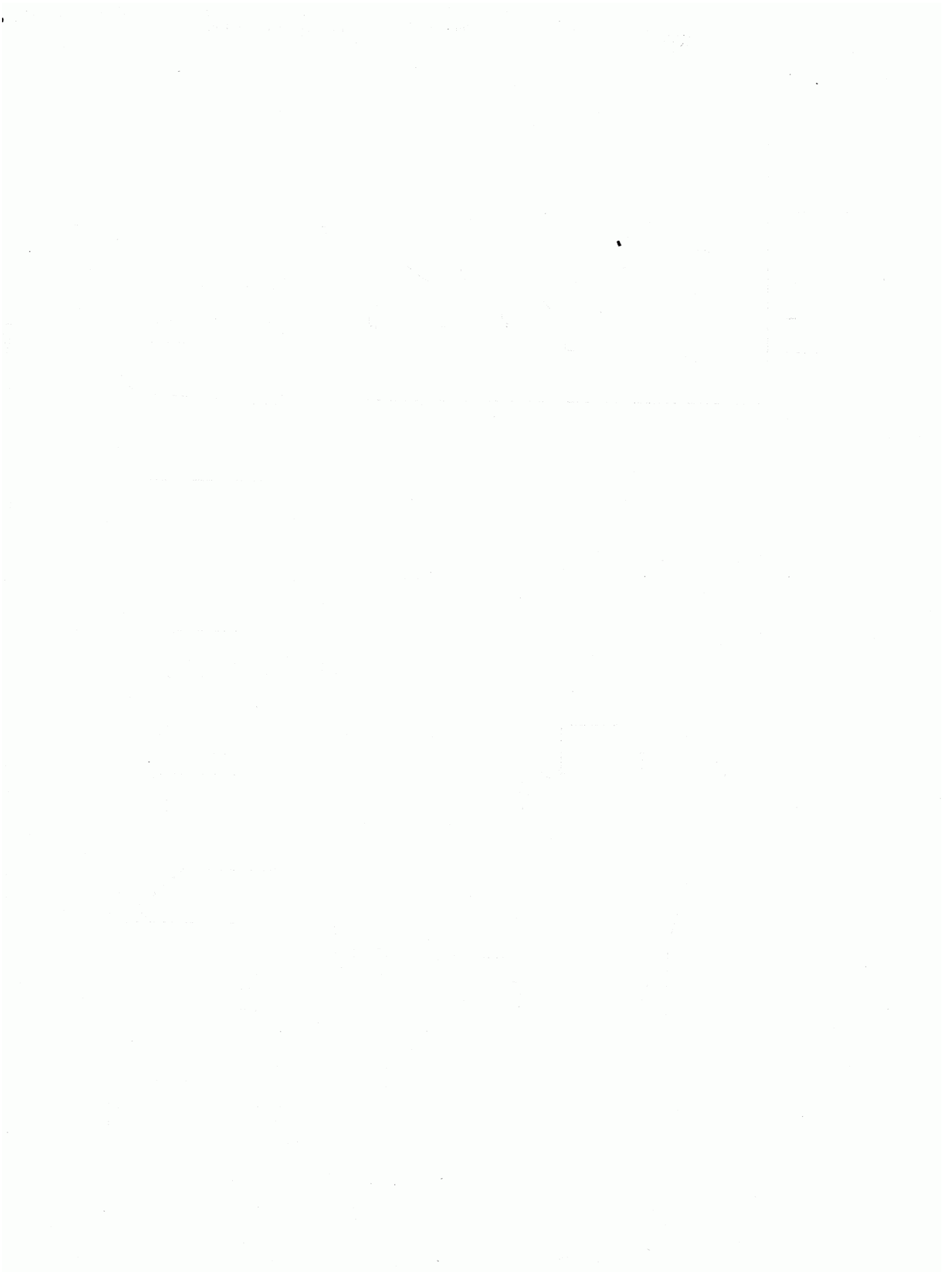

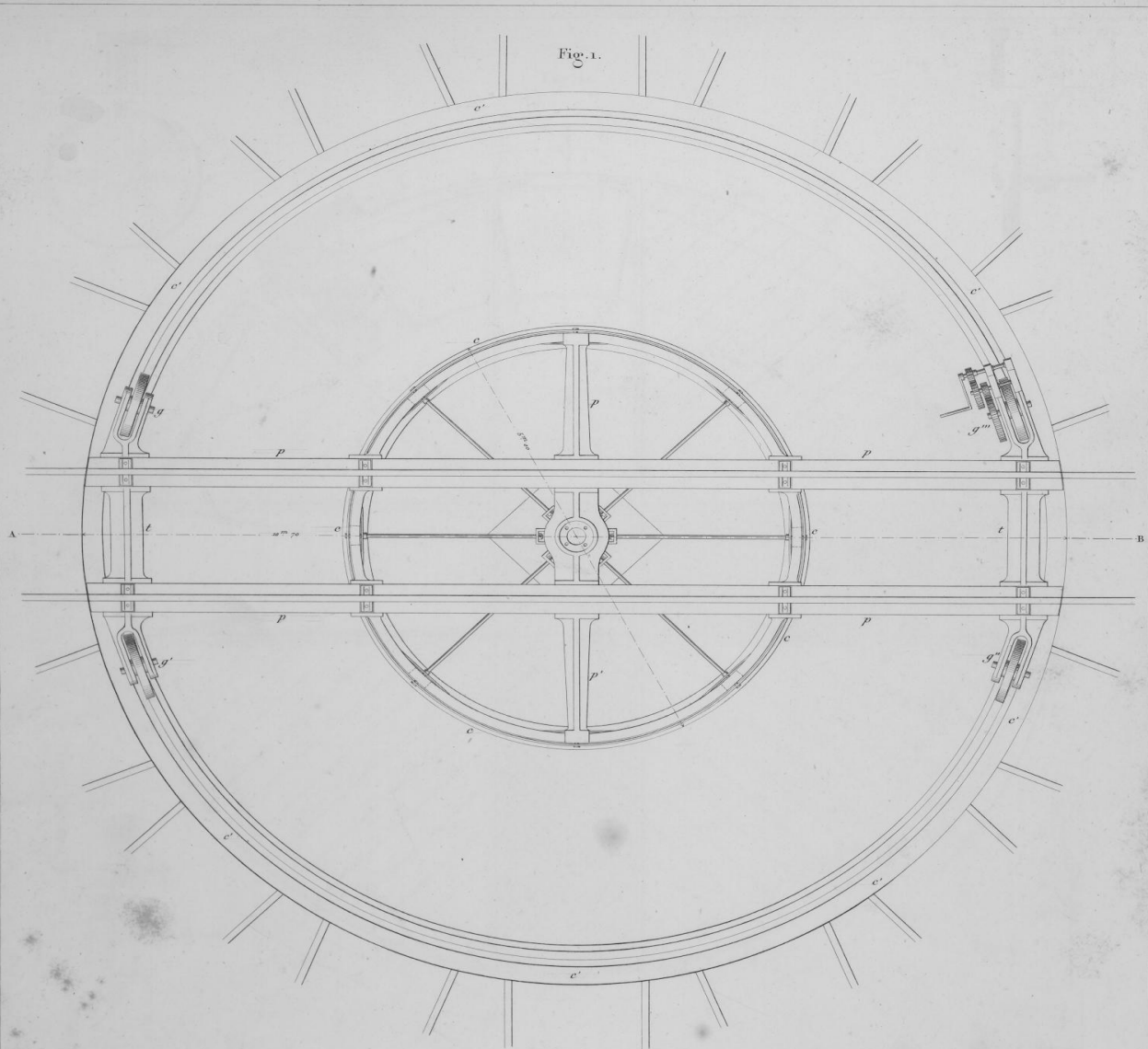

Fig. 1.

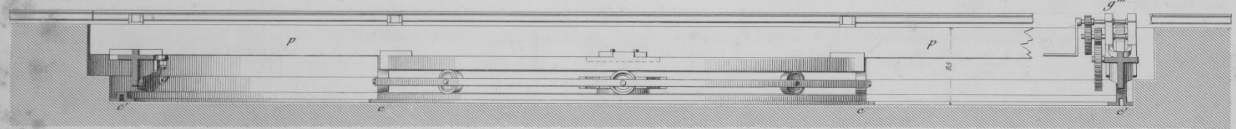

Fig. 2.

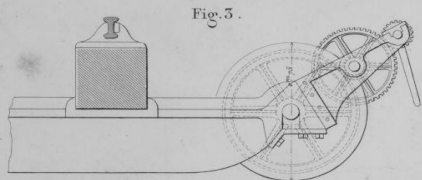

Fig. 3.

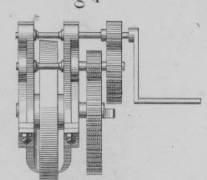

Fig. 4.

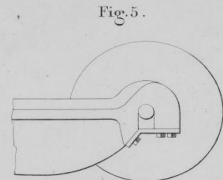

Fig. 5.

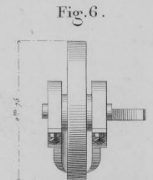

Fig. 6.

Echelle de 0^m 02 pour mètre = 1/50 pour les fig. 1 et 2.

Echelle de 0^m 04 pour mètre = 1/25 pour les détails.

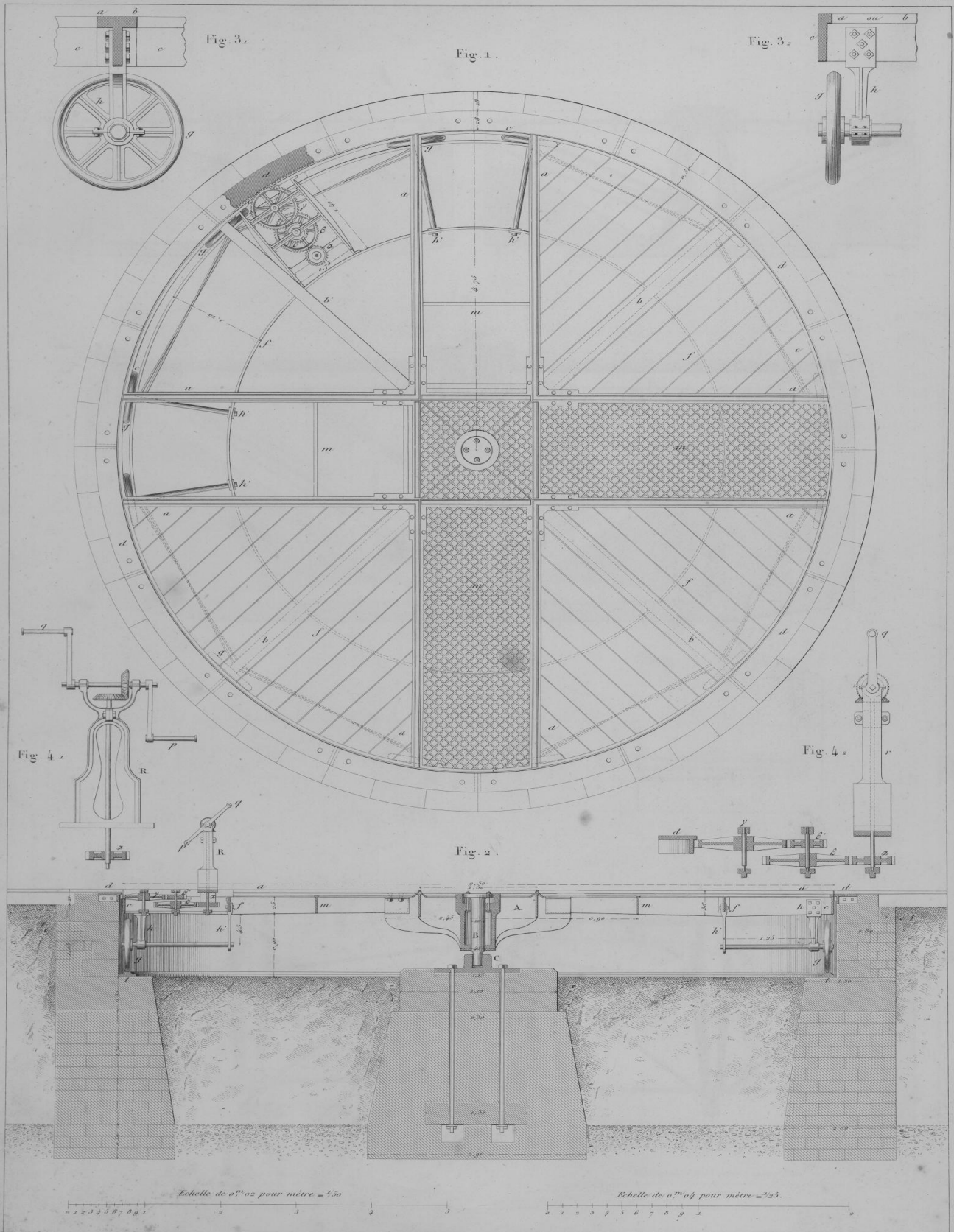

Fig. 1.

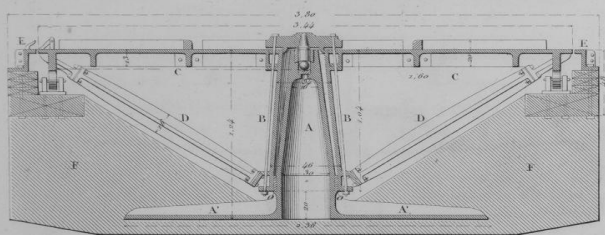

Fig. 2.

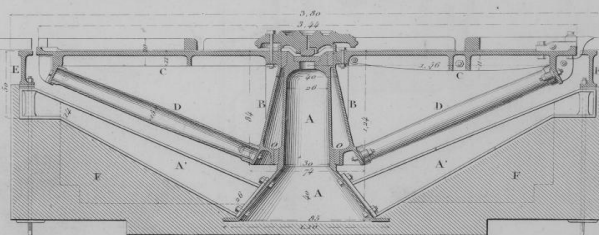

Fig. 3.

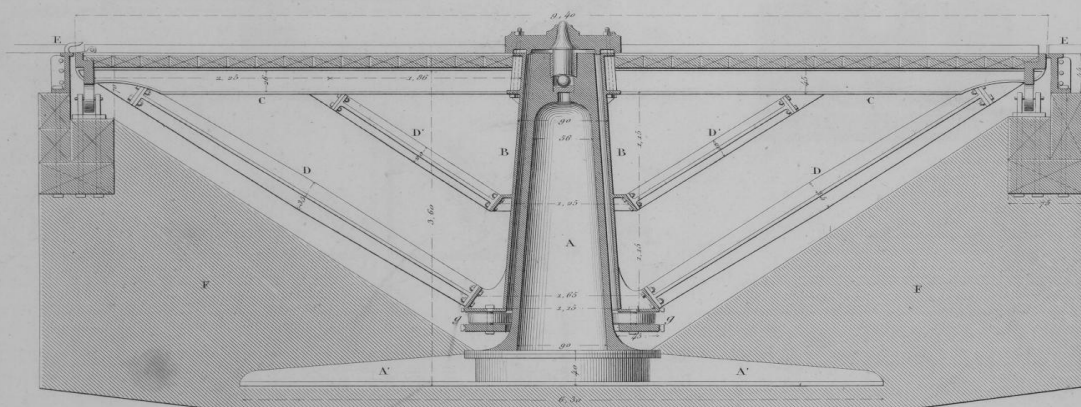

Fig. 4.

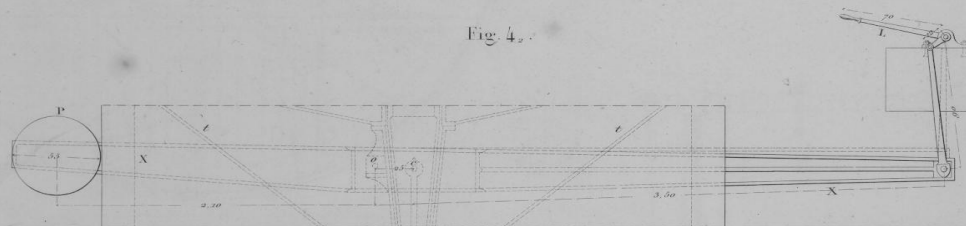

Fig. 4.

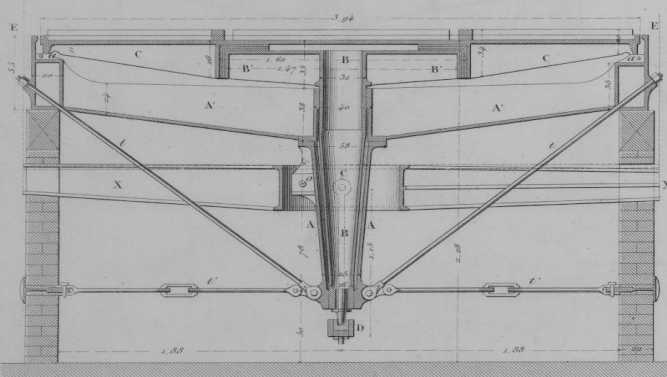
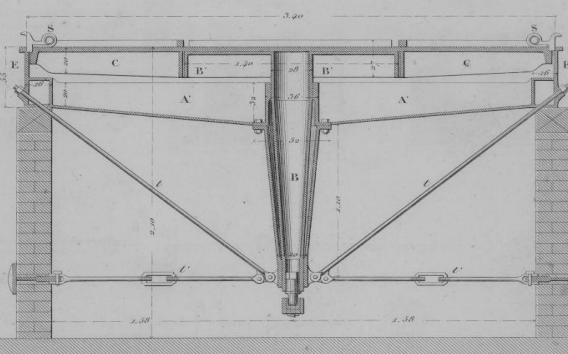

Fig. 5.



Echelle de 0^m02 pour 1 mètre 450.



Echelle de 0^m03 pour 1 mètre 50000.

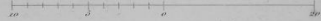

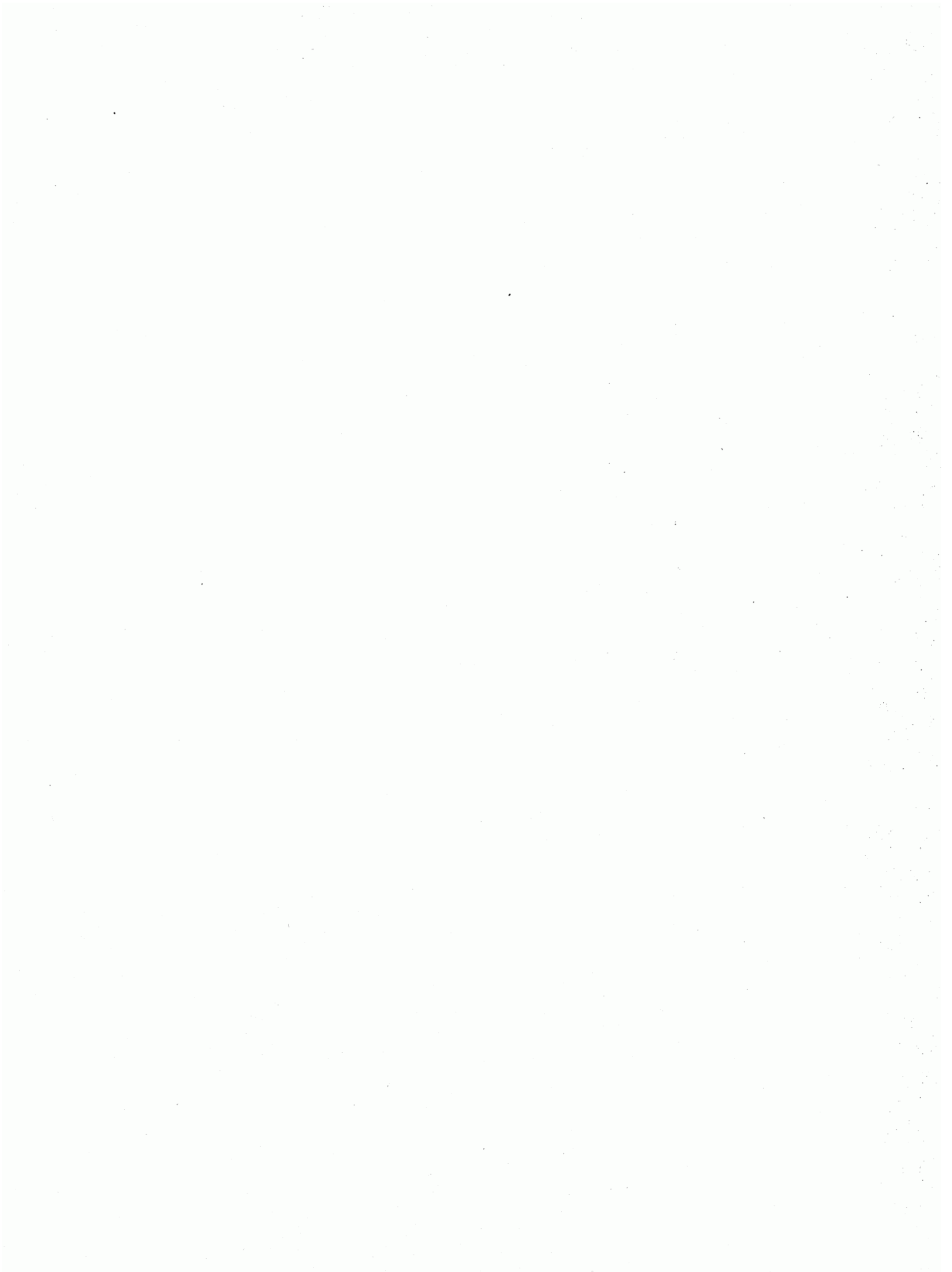

Fig. 1.

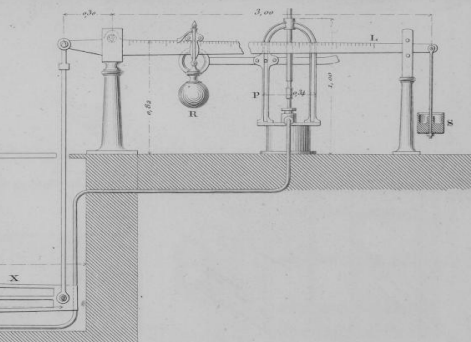
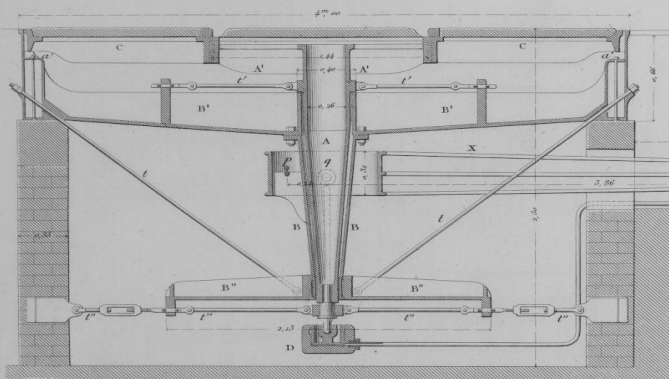

Fig. 1.

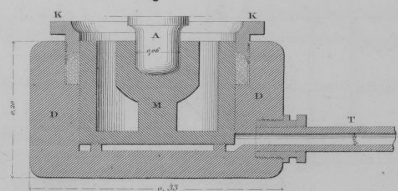

Fig. 1.

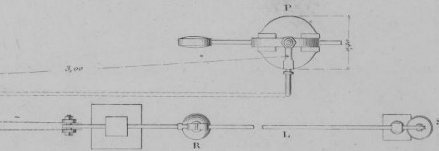
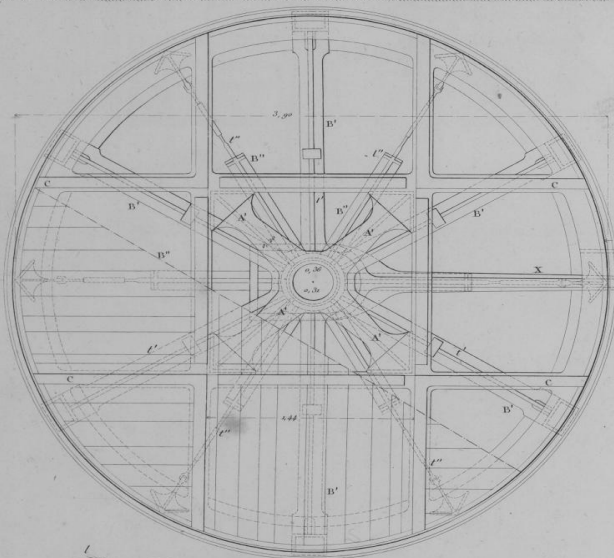

Fig. 2.

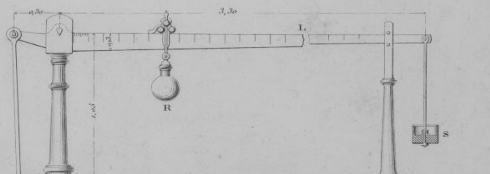
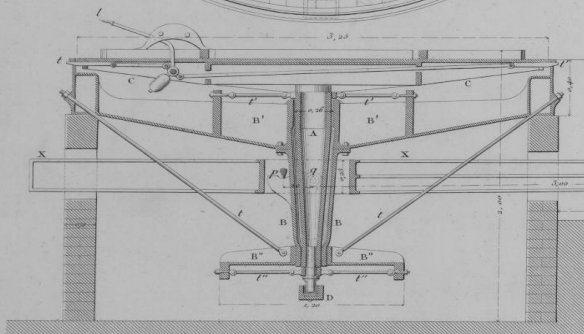

Fig. 2.

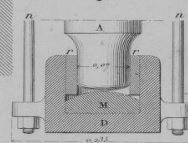

Fig. 2.

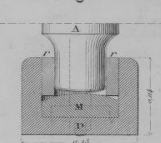
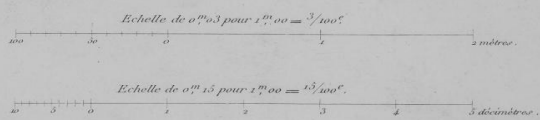
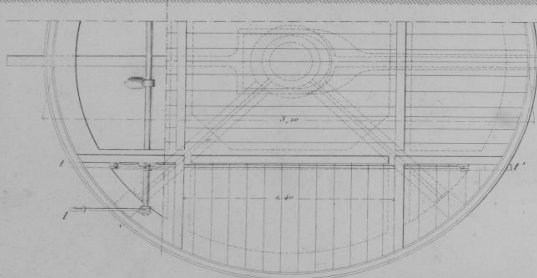

Fig. 2.



Diligences belges.

Fig. 1.

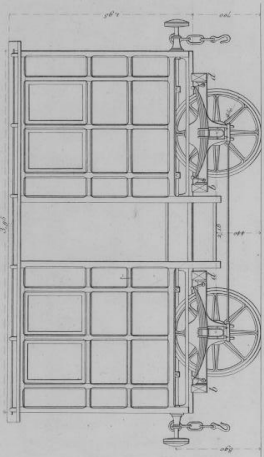

Fig. 2.

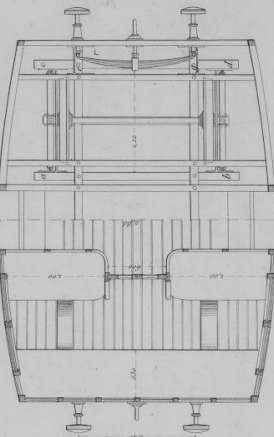

Fig. 3.

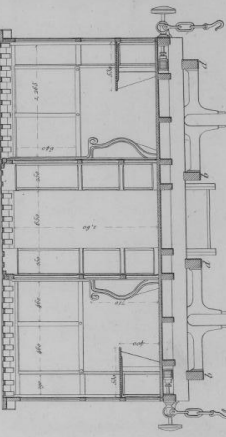

Fig. 5.

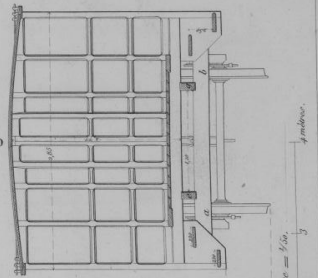
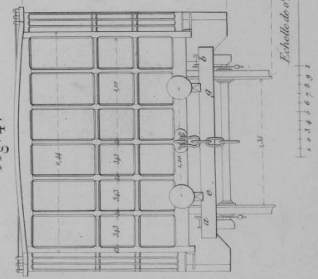

Fig. 4.



Echelle de 0,100 pour metre = 1/10.
1 2 3 4 5 6 7 8 9 10

Fils Mathias direct.

Waggons belges.

T. 1.

Fig. 6.

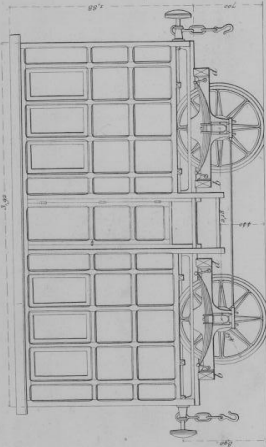

Fig. 7.

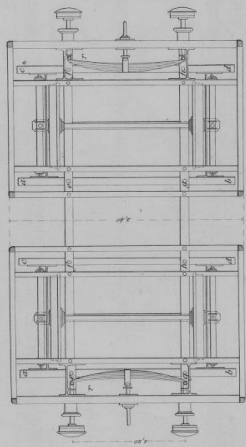

Fig. 8.

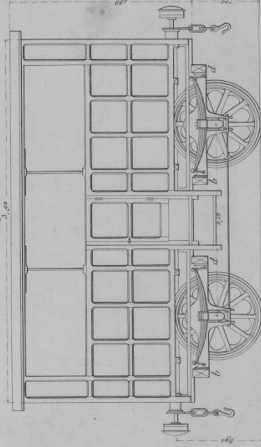

Fig. 9.

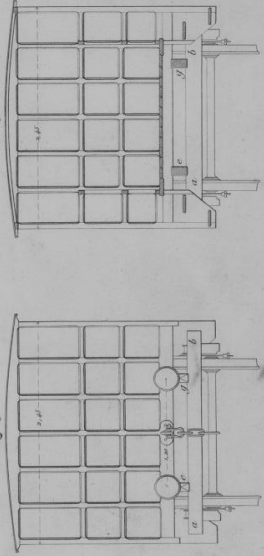
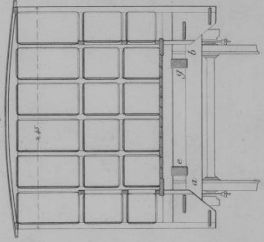

Fig. 10.



Echelle de 0,100 pour metre = 1/10.
1 2 3 4 5 6 7 8 9 10

Fils Mathias sculp.

Fils Mathias, Editeur, quai Malgouais, 15.

Fig. 1.

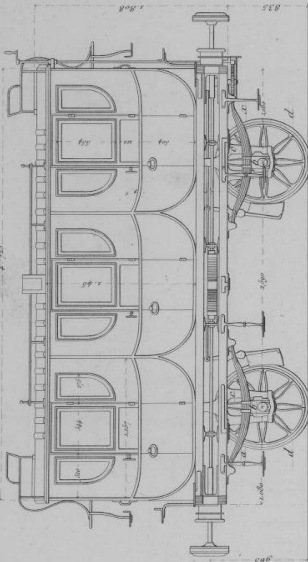

Fig. 2.

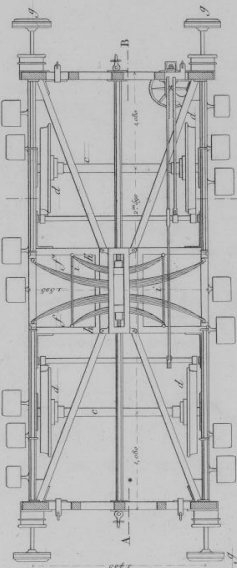

Fig. 3.

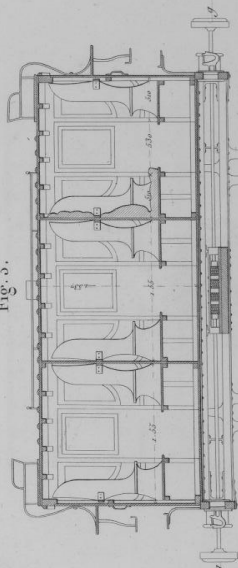

Fig. 4.

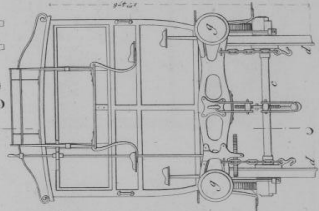

Fig. 5.

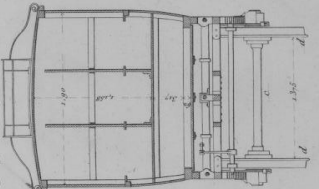

Fig. 6.

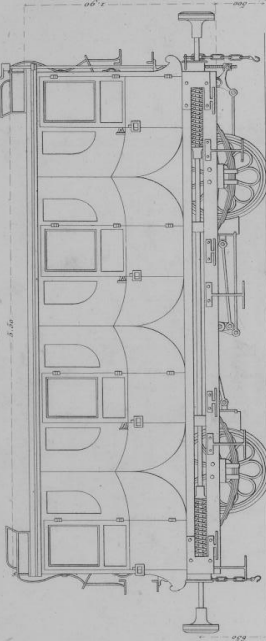

Fig. 7.

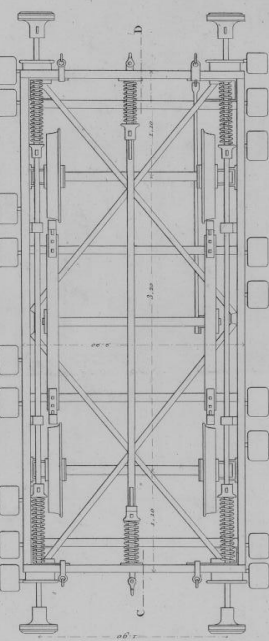

Fig. 8.

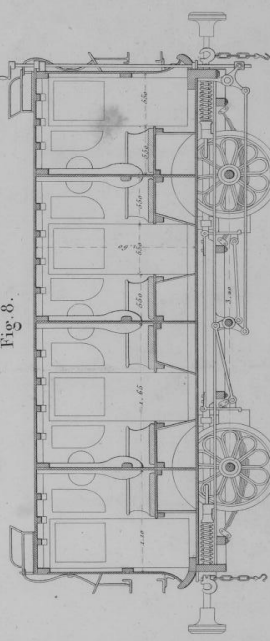

Fig. 9.

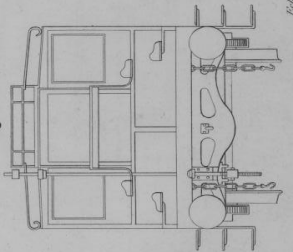
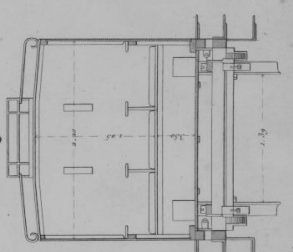

Fig. 10.



Echelle de 6^{tes} pour 1 mètre.

Echelle de 6^{tes} pour 1 mètre.

Waggon de 2^e classe (L. à Birmingham).

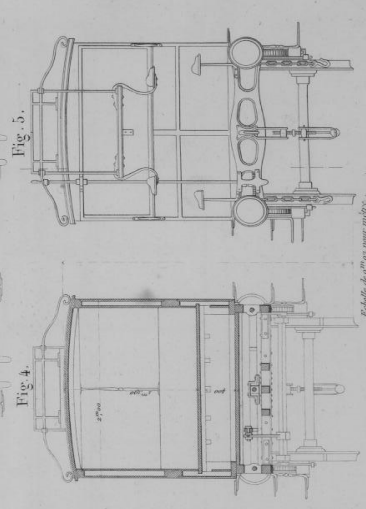
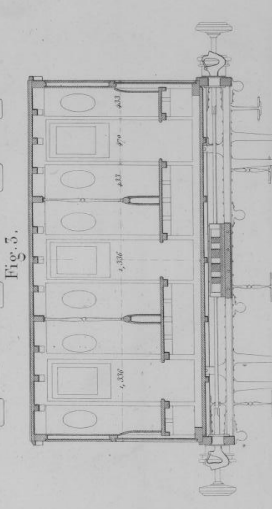
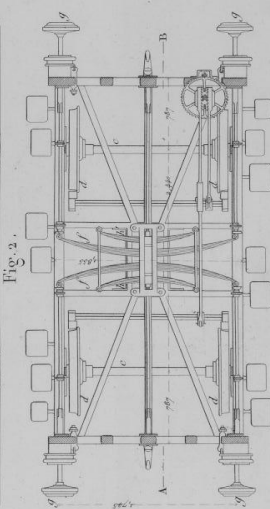
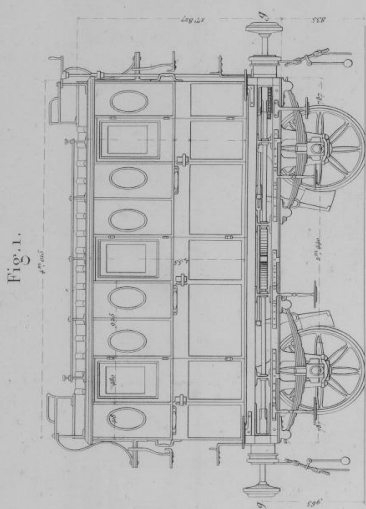

Waggon de 3^e classe (L. à Birmingham).

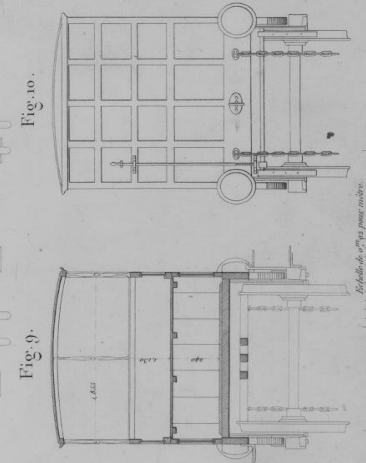
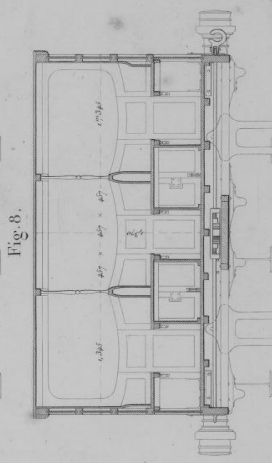
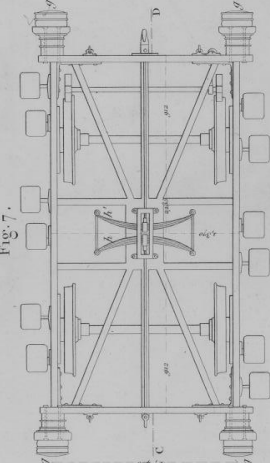
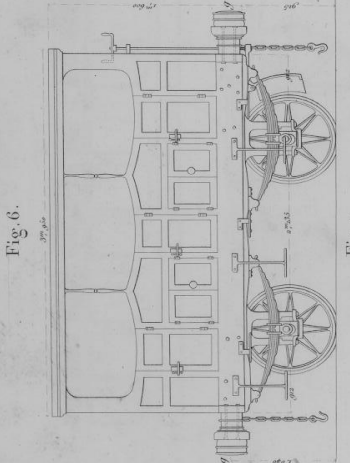

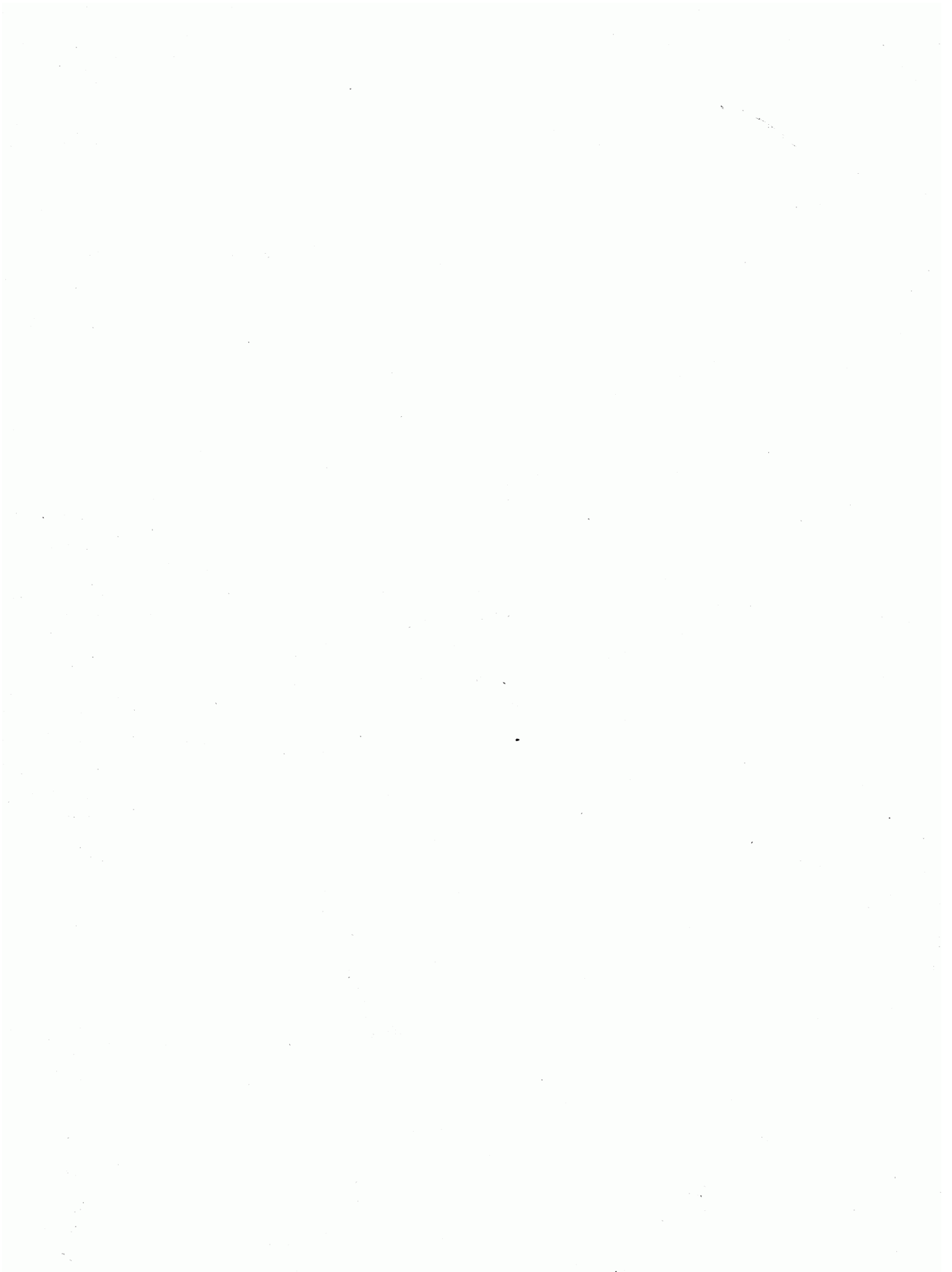

Fig. 1.

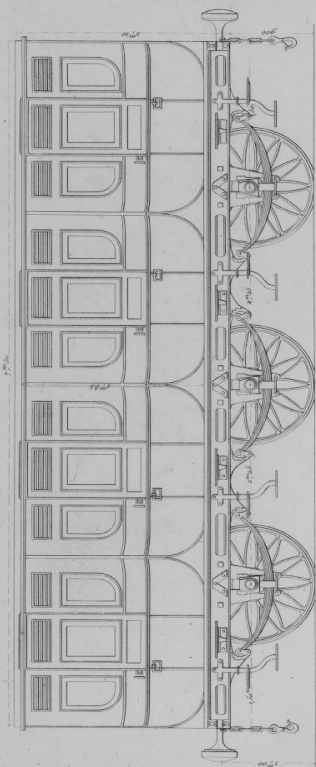

Fig. 5.

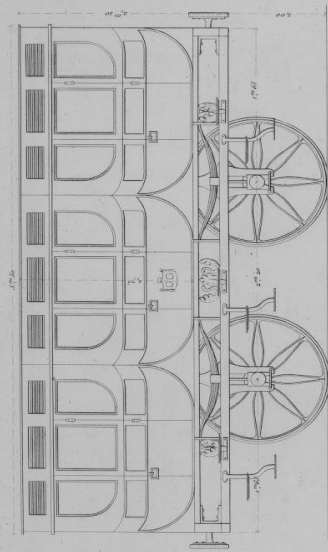

Fig. 4.

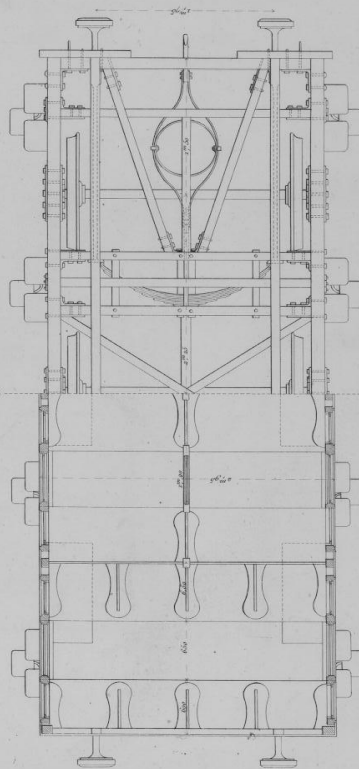

Fig. 3.

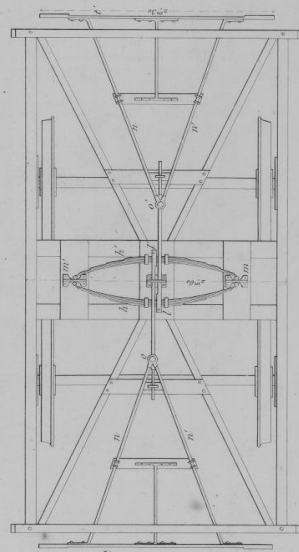

Fig. 2.

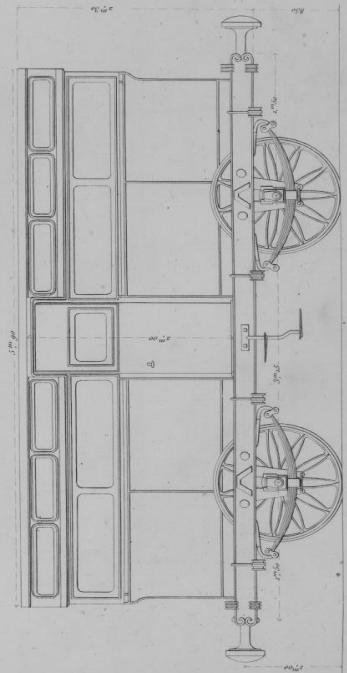

Fig. 2.

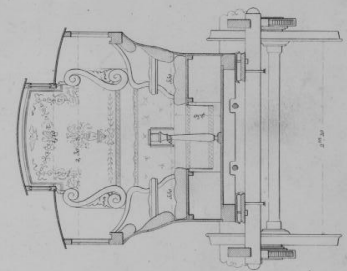
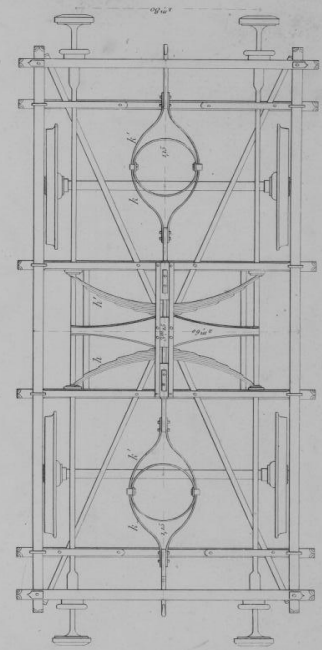

Fig. 2.



Echelle de 0^m125 pour mètres = 1/50
1 2 3 4 5 6 7 8 9 10

Fig. 1.

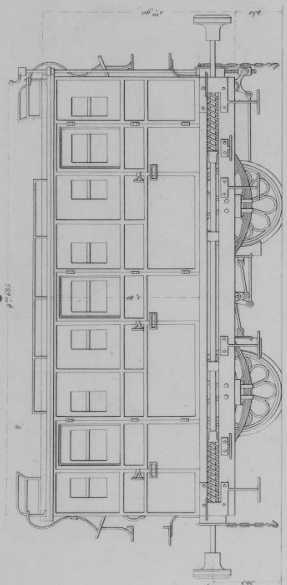

Fig. 2.

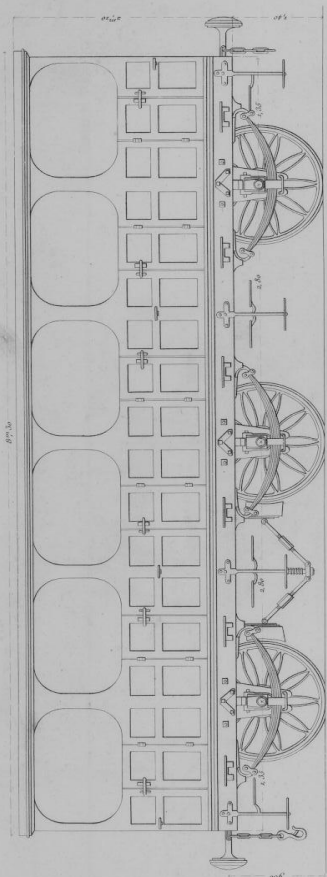

Fig. 1.

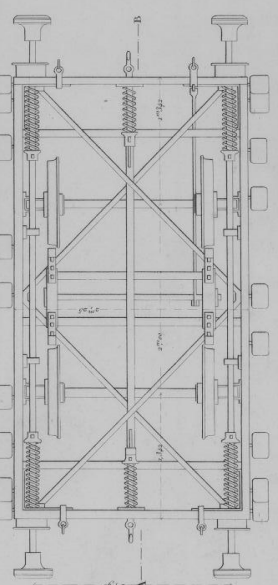

Fig. 2.

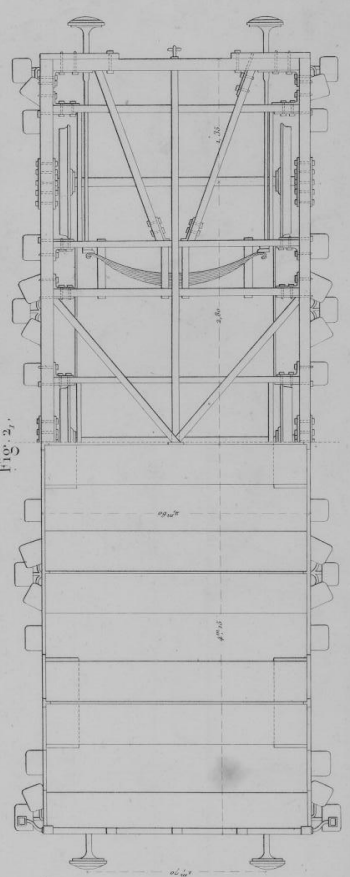

Fig. 1.

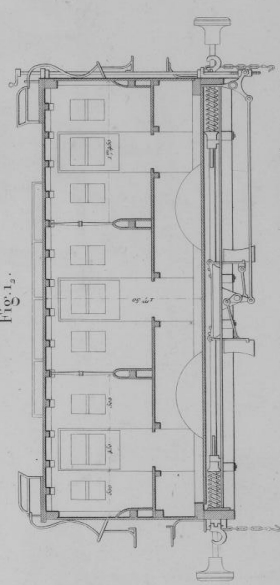

Fig. 5.

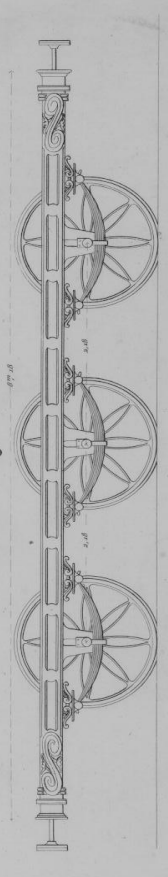

Fig. 4.

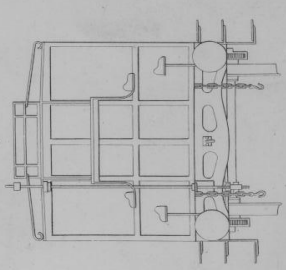
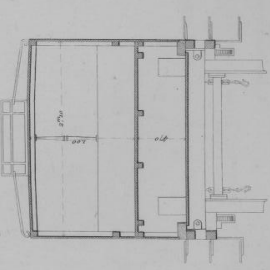

Fig. 3.



Échelle de 0,001 m pour les parties en 1/50
0 1 2 3 4 5 6 7 8 9 10
Mètres



Freins de Wagons de Versailles (R.G.).

F. 6.

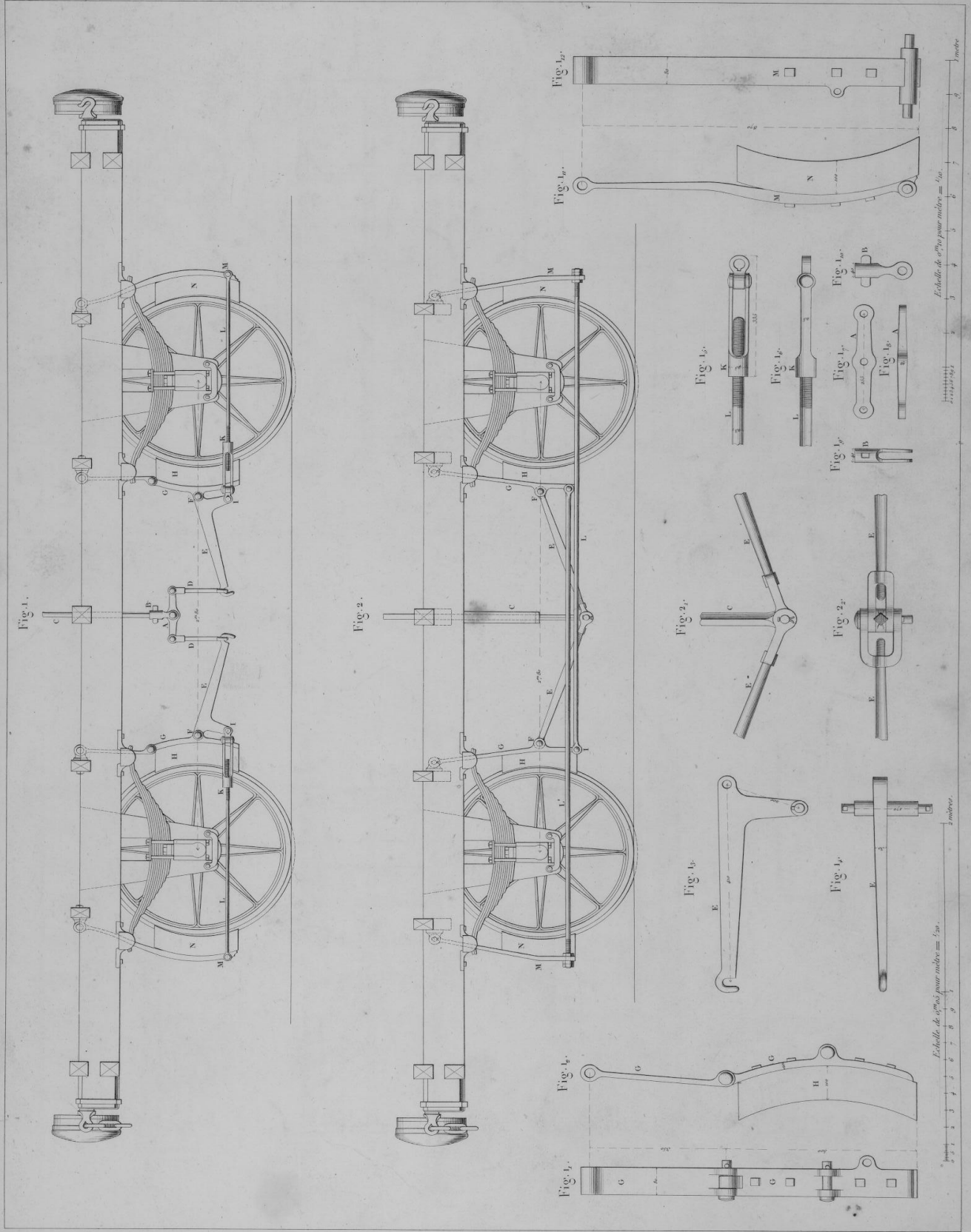

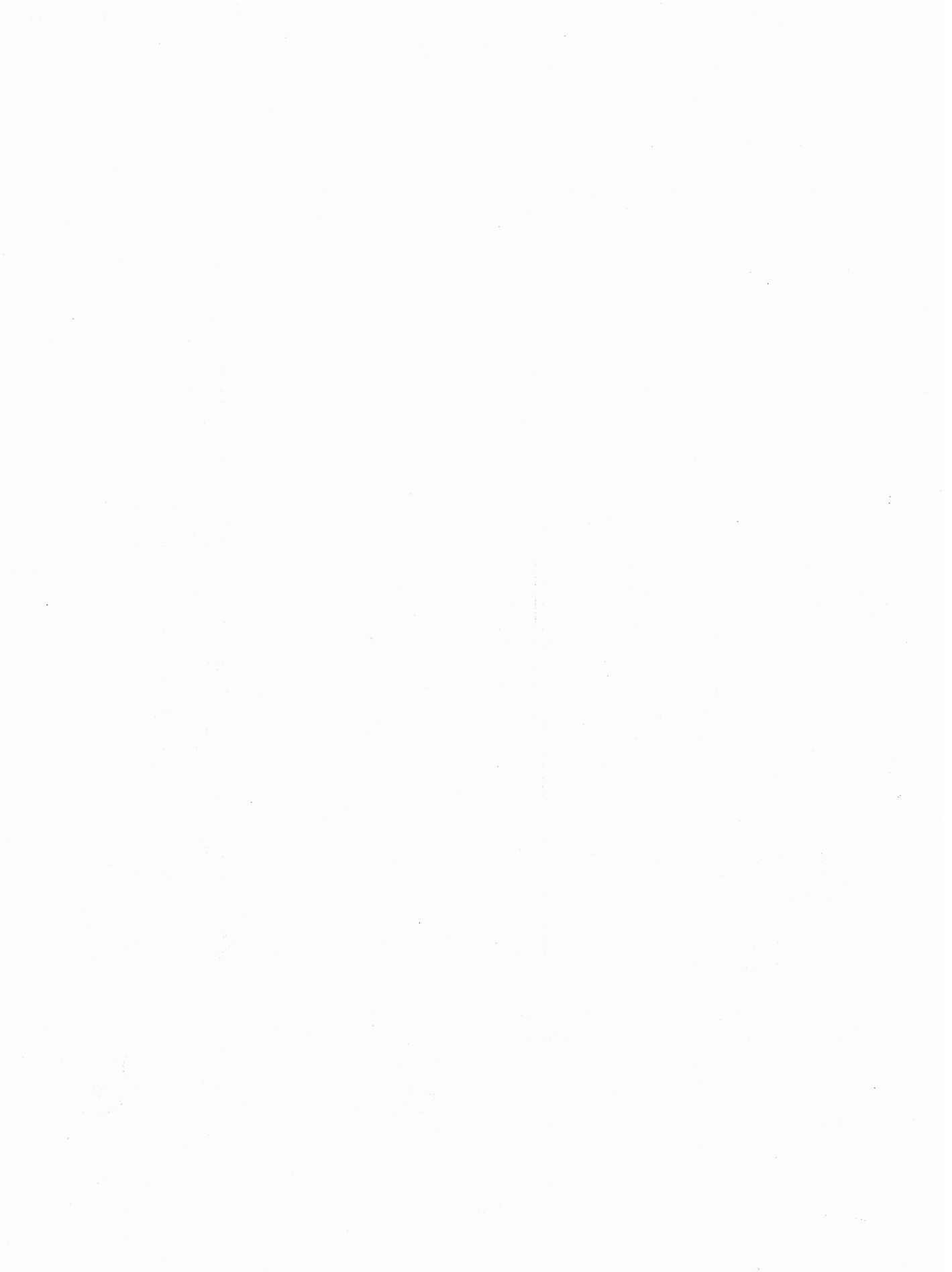

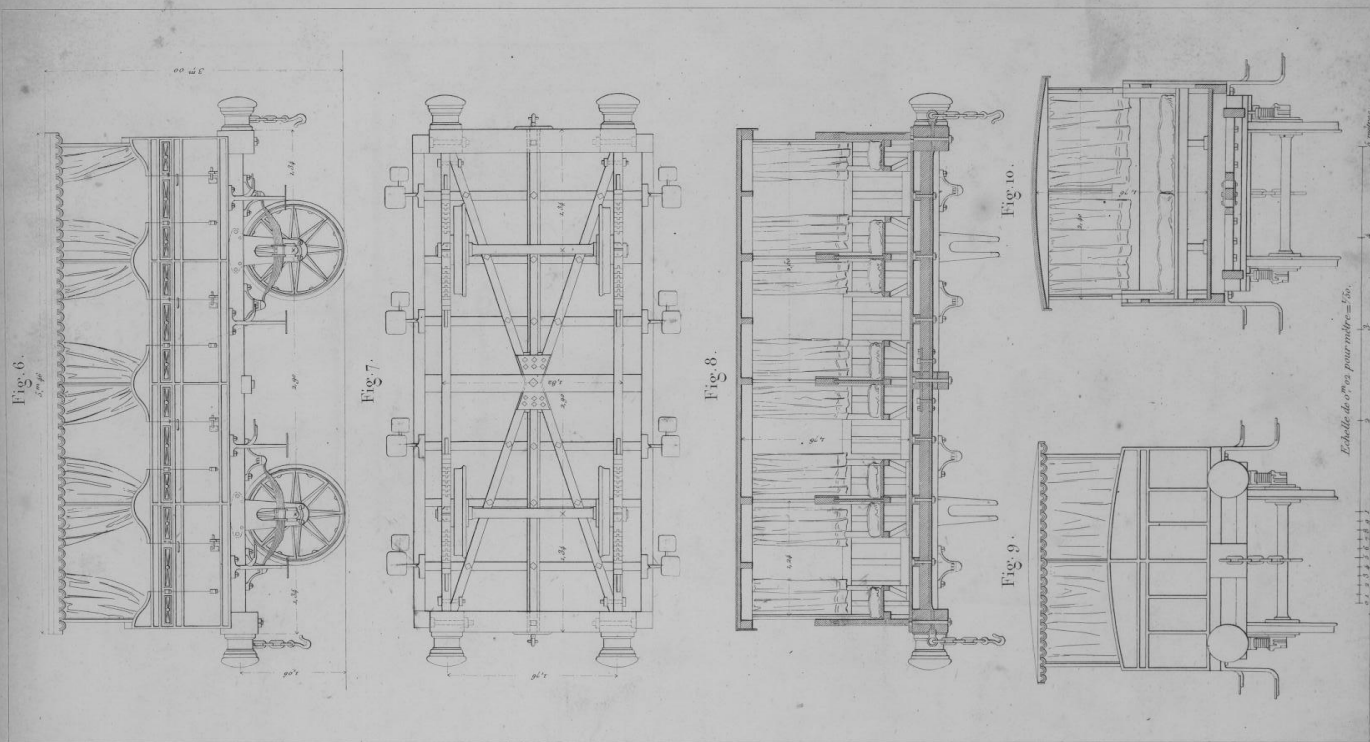
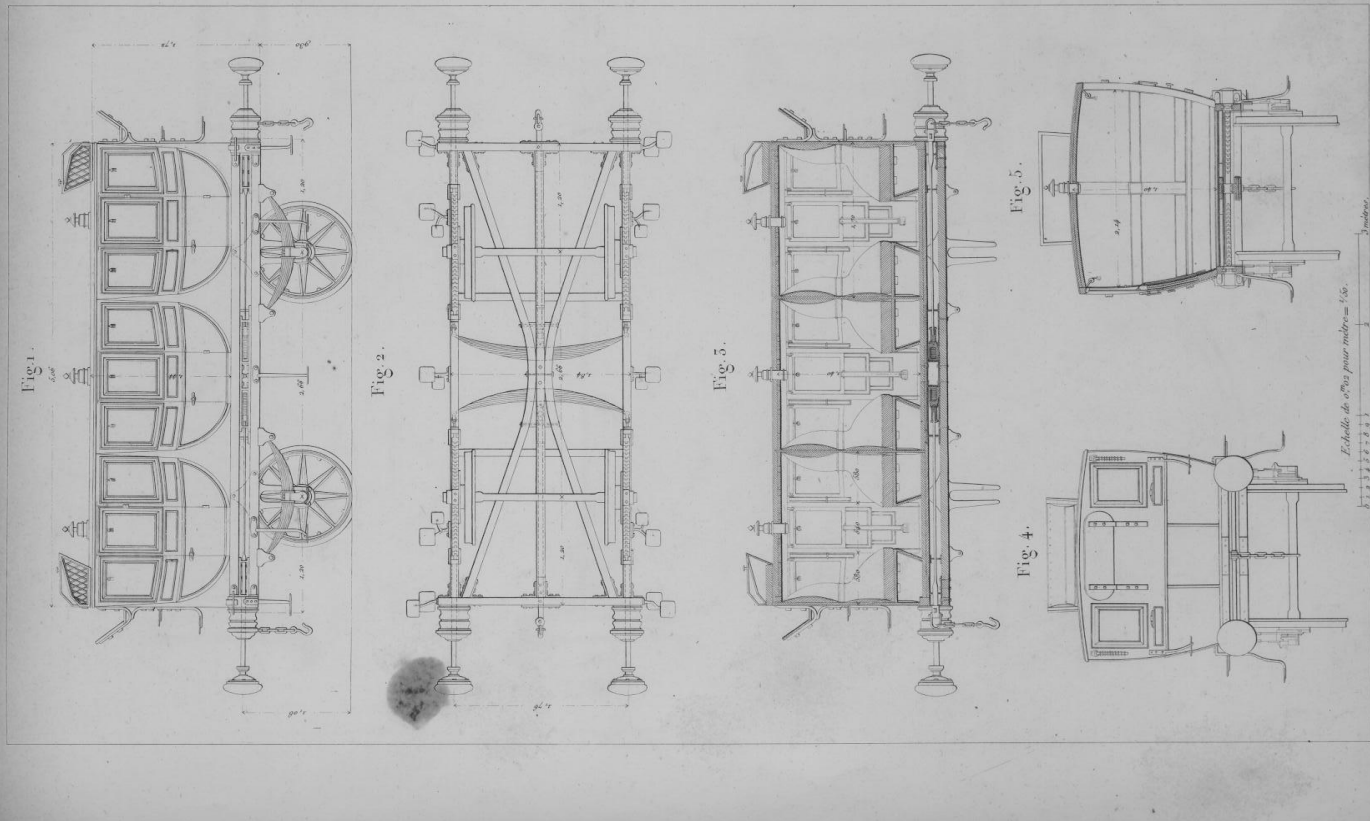

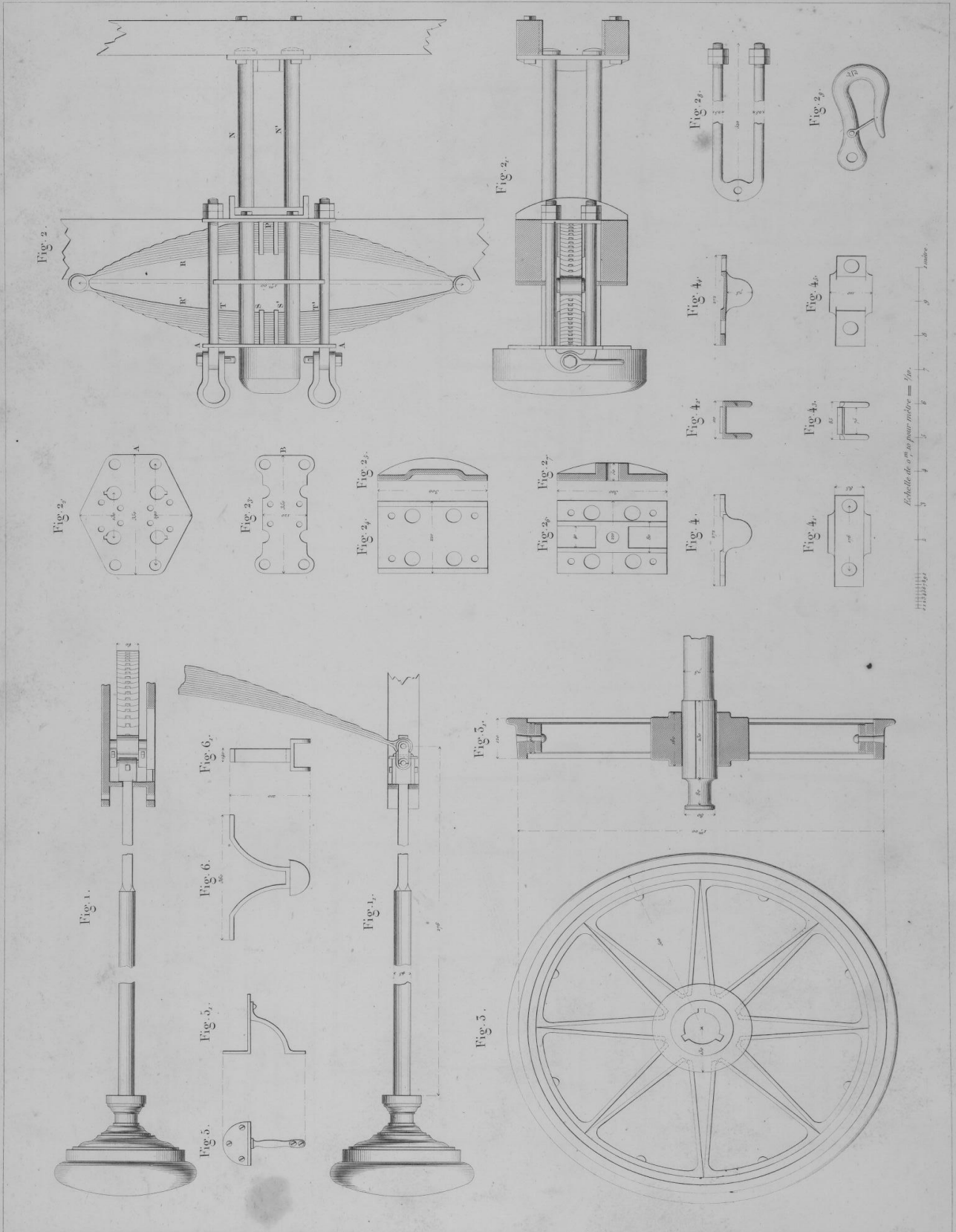

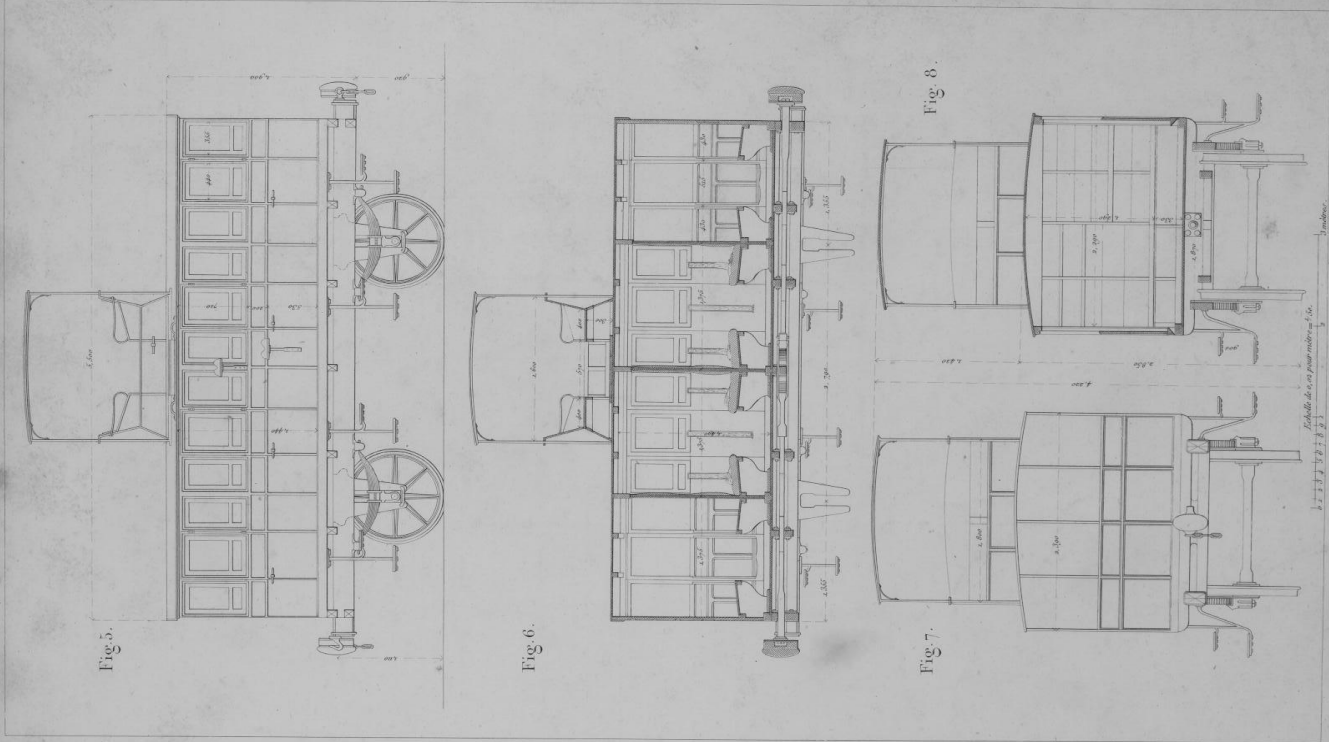
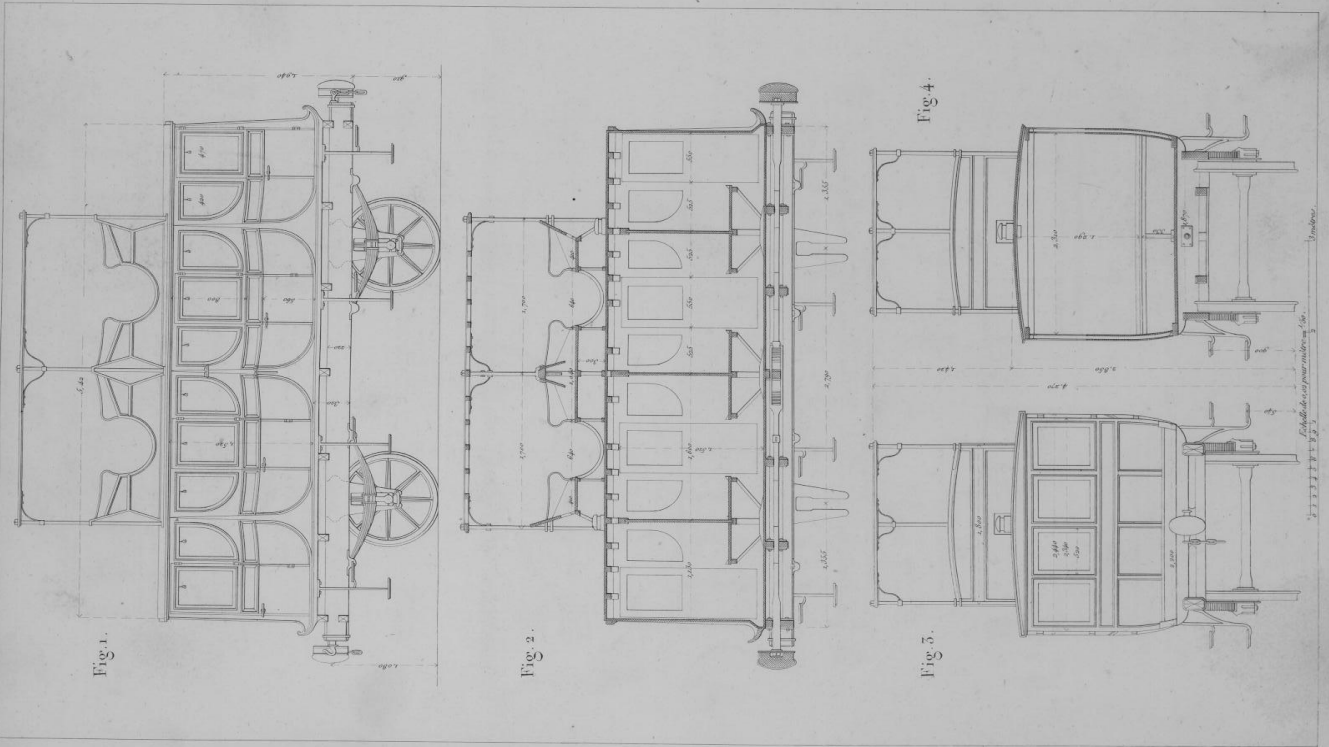

Voiture mixte de Versailles (R.G).

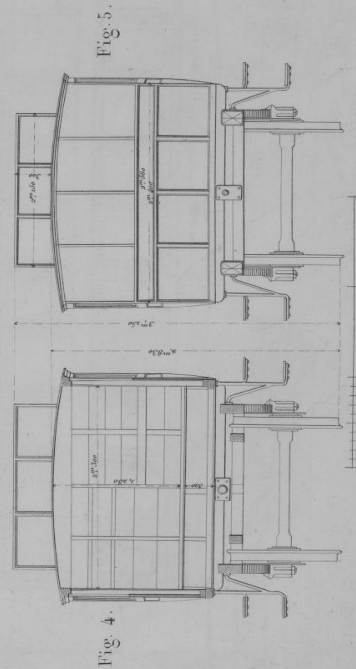
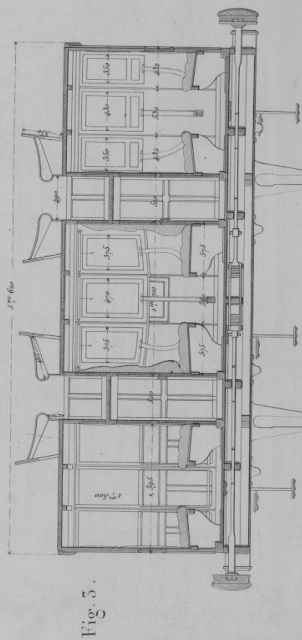
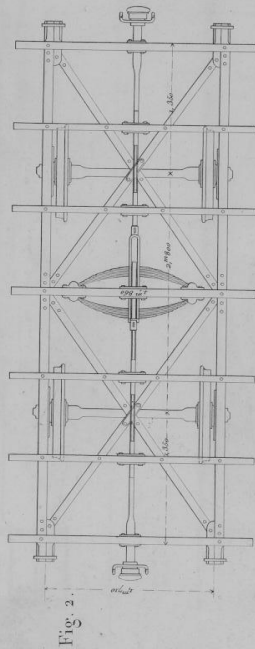
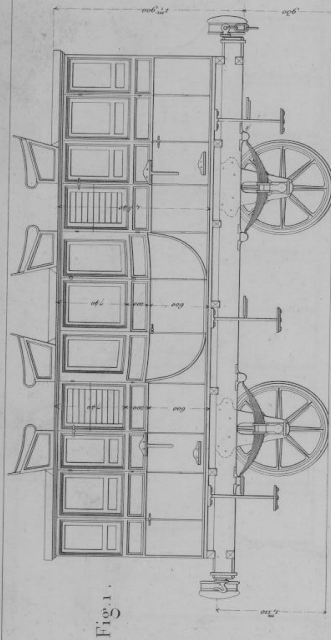

Waggon de Versailles (R.G).

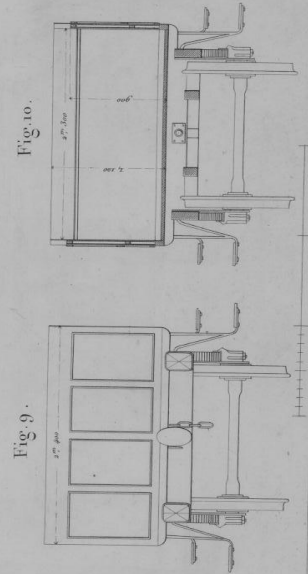
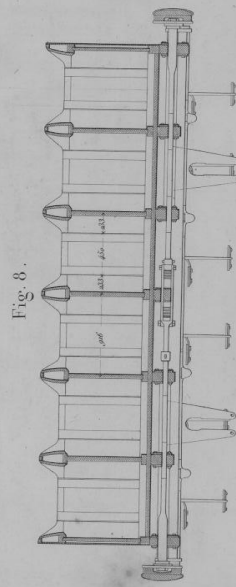
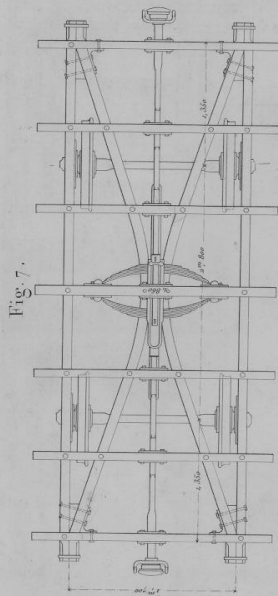
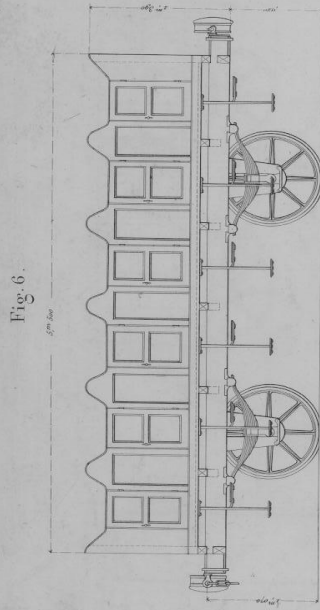



Voitures du chemin dit Nordbahn (à Vienne) et du chemin de Bâle à Strasbourg.

F. II.

Fig. 1.

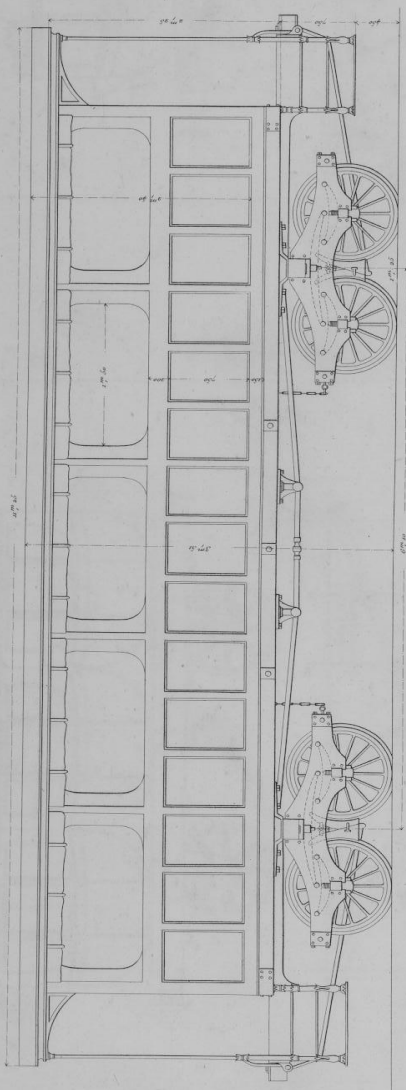

Fig. 2.

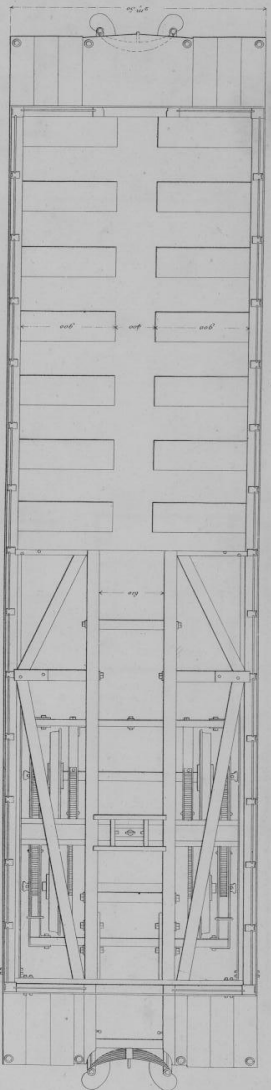

Fig. 3.

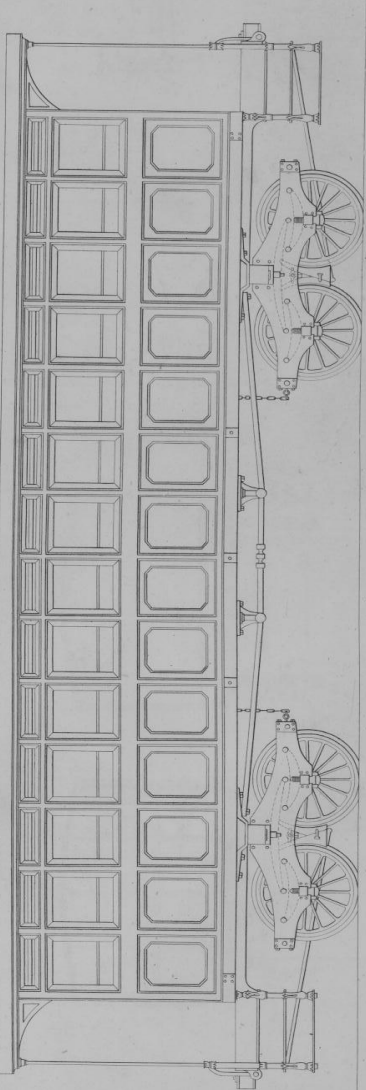

Fig. 4.

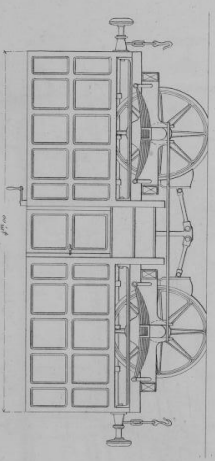

Fig. 5.

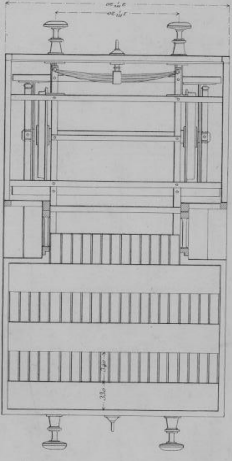

Fig. 6.

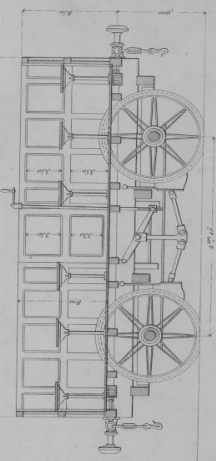

Fig. 7.

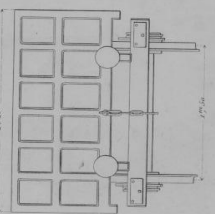
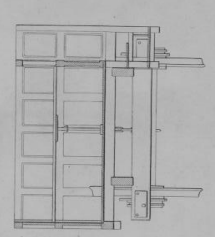

Fig. 8.



Échelle de 0^m25 pour mètres = 1/10.
0 1 2 3 4 5 6 7 8 9 10
1 mètre.



Berlines, chemin de fer de Versailles (R.G.).

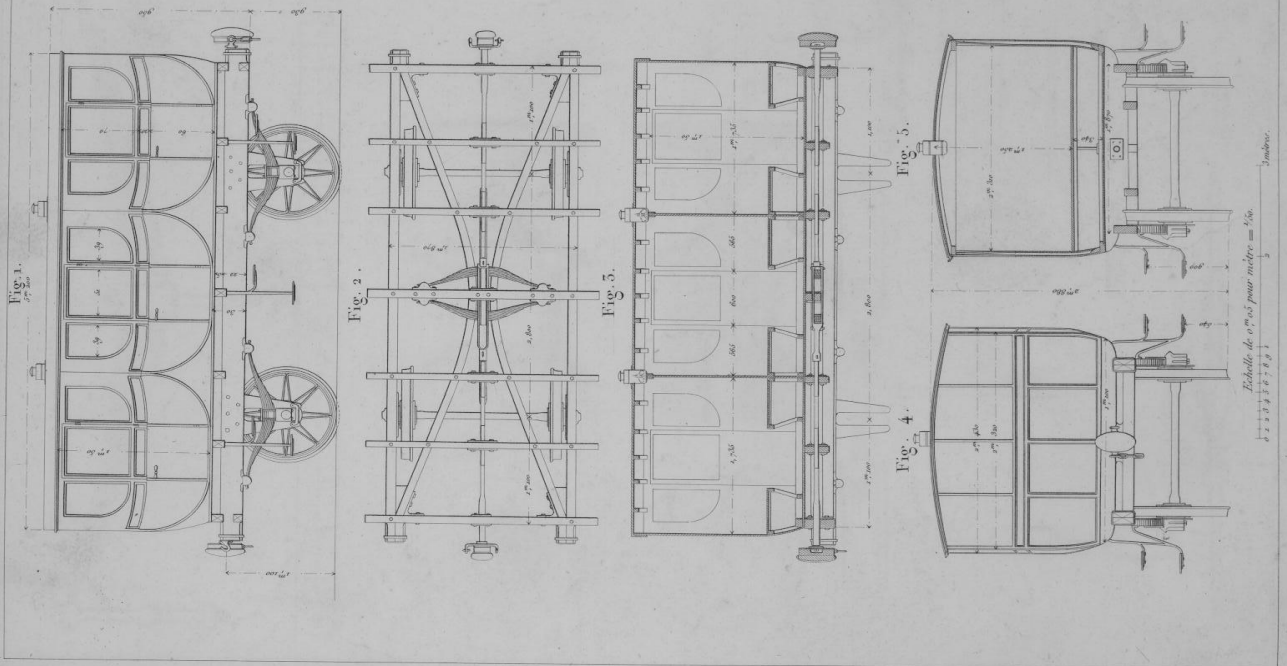

Voiture de luxe.

F. 12.

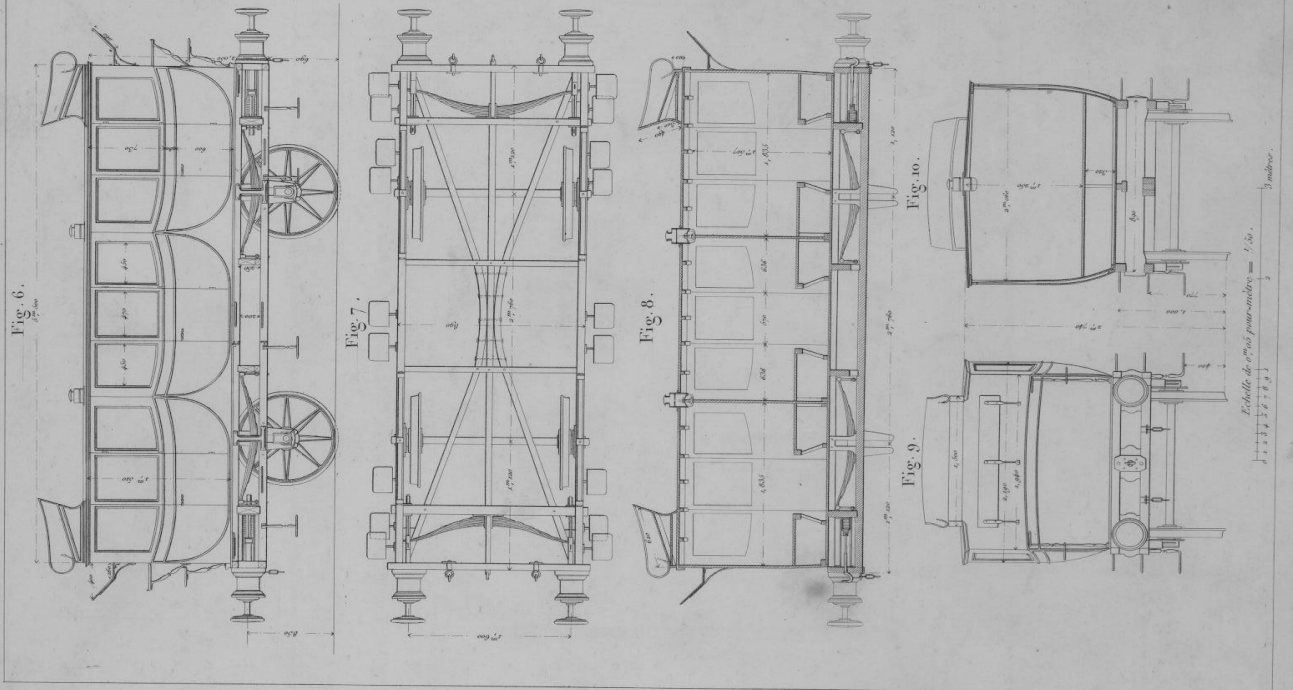



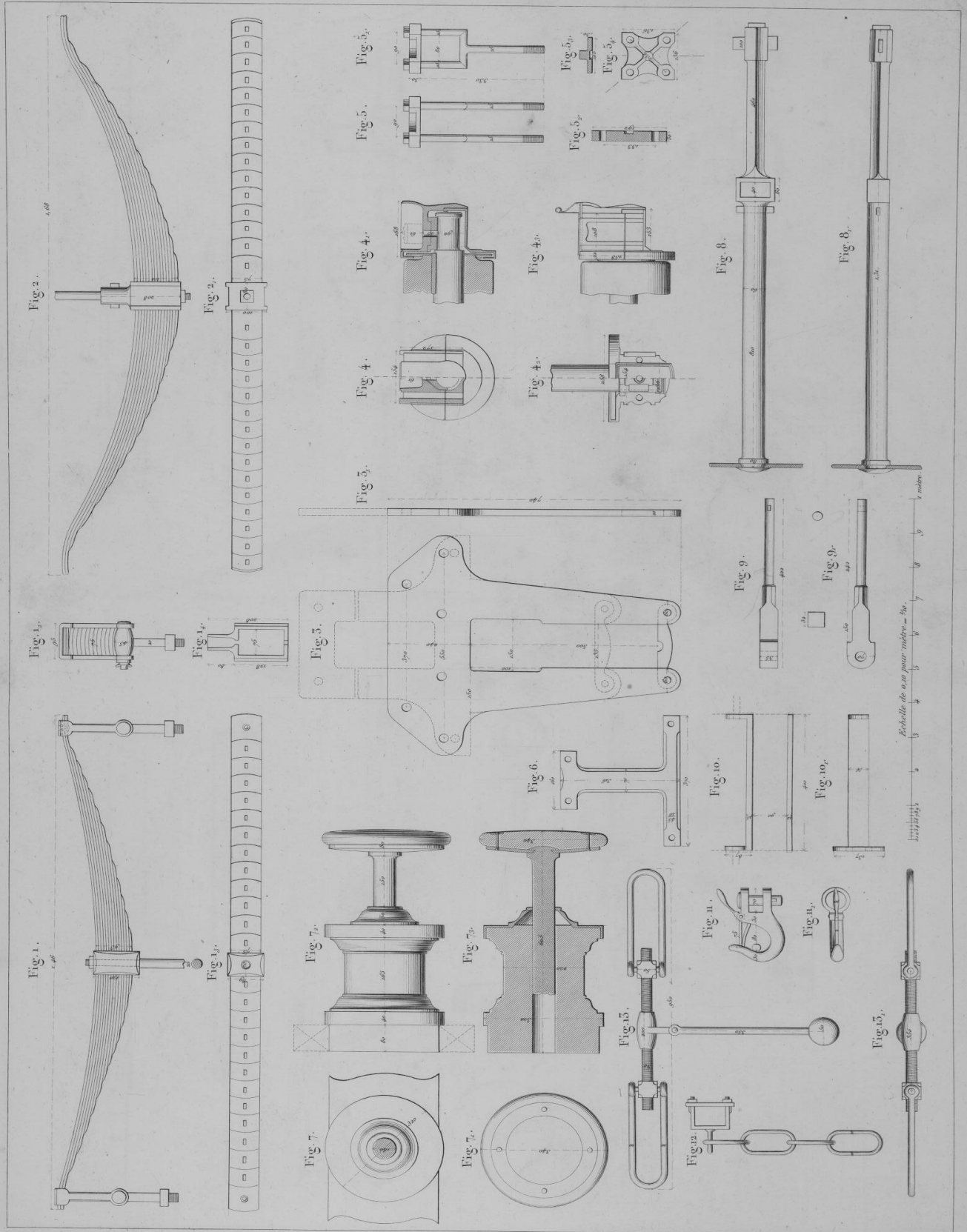

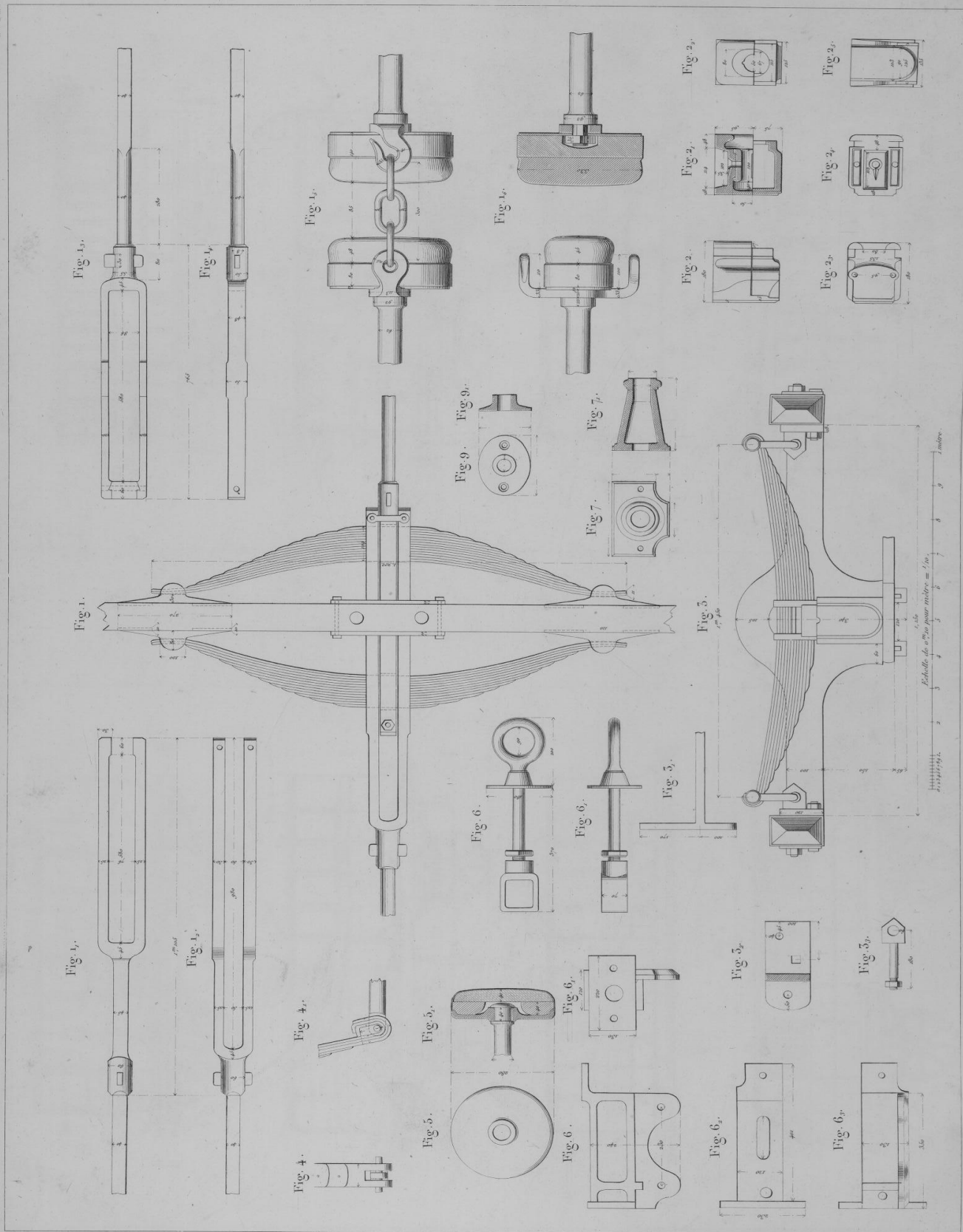

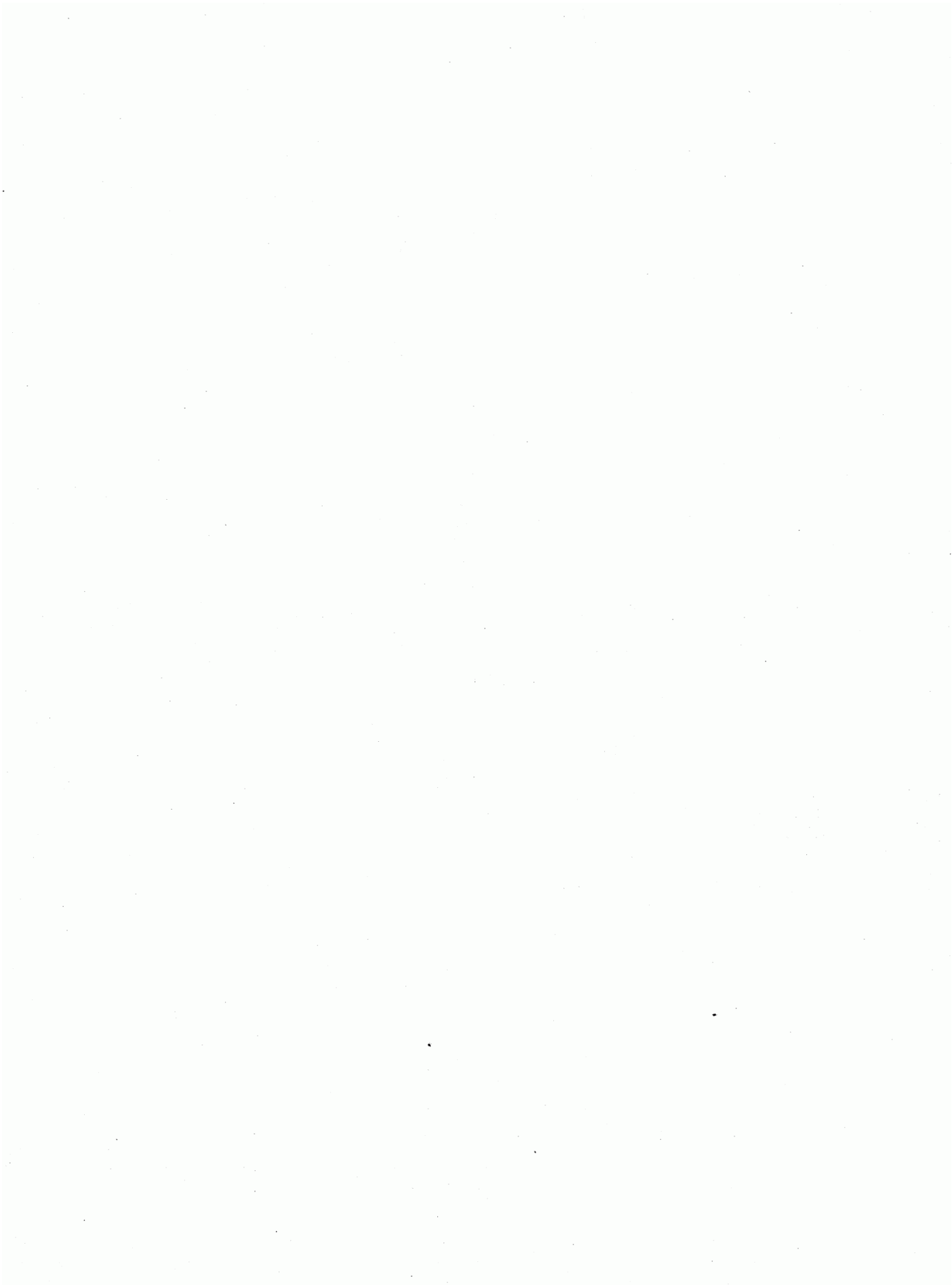

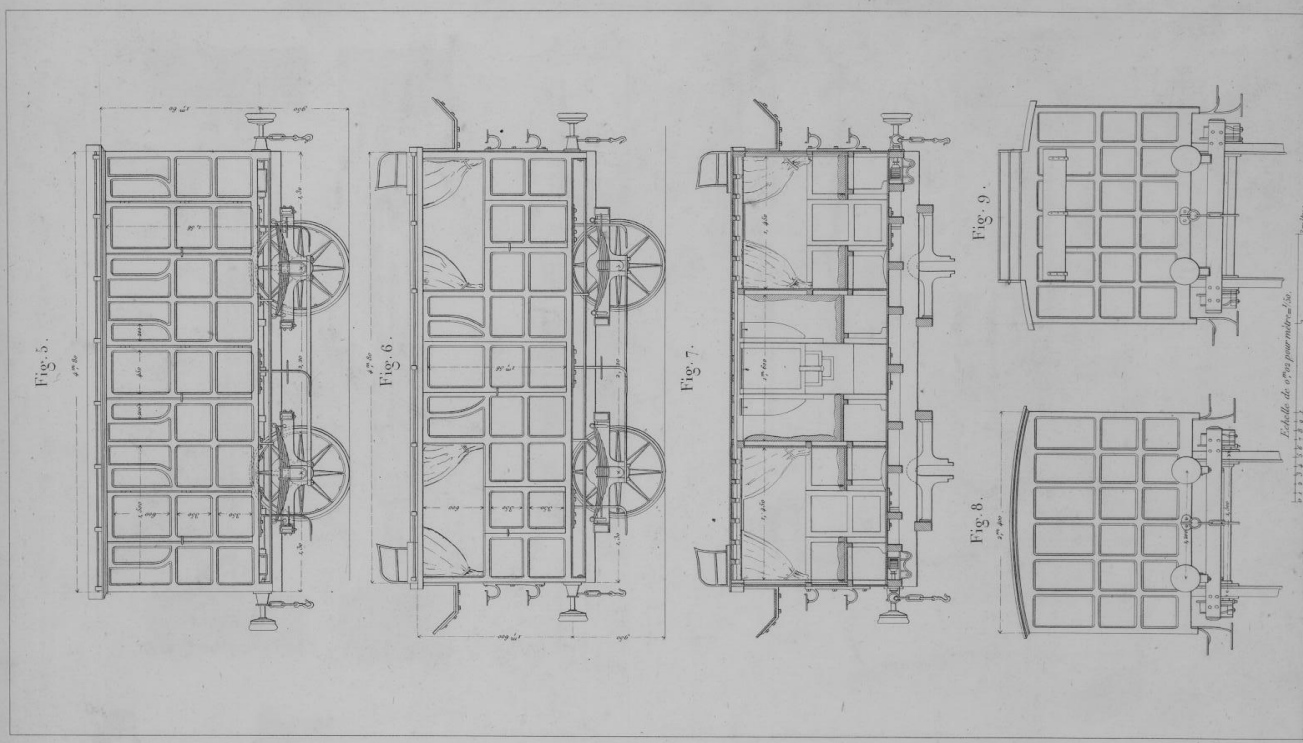
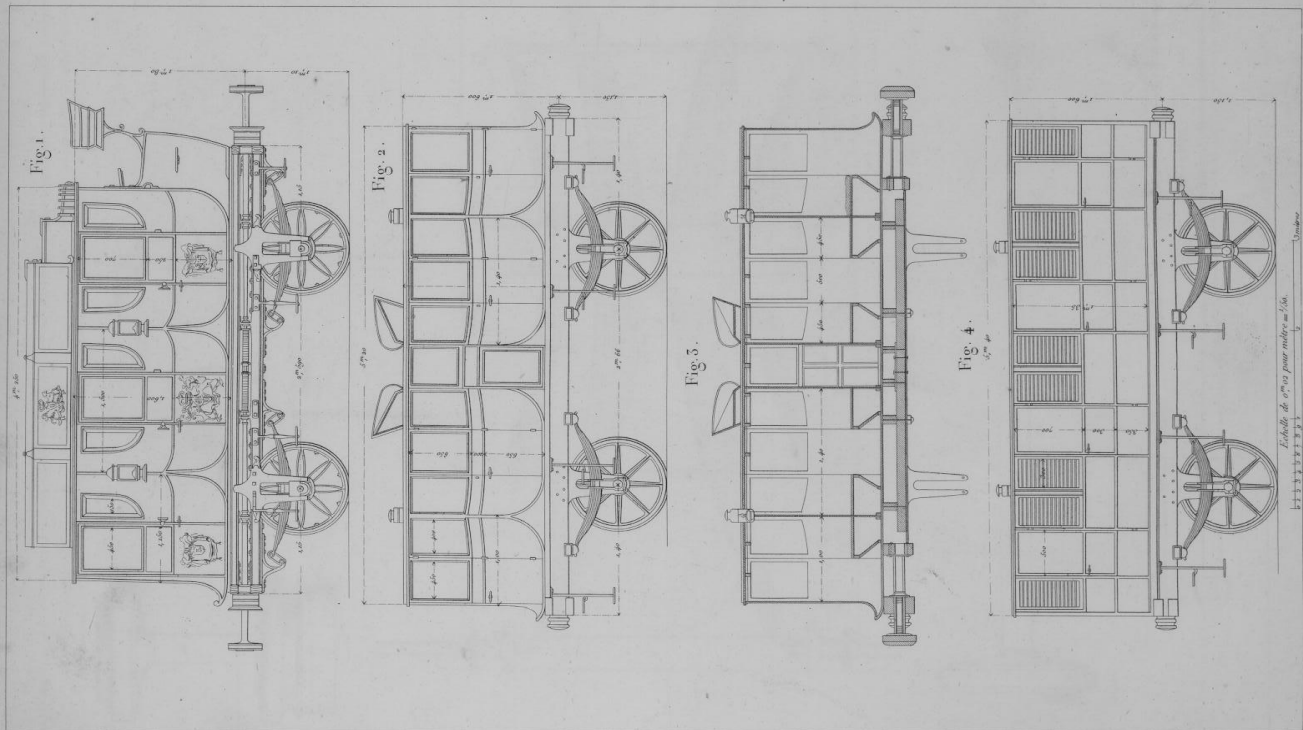

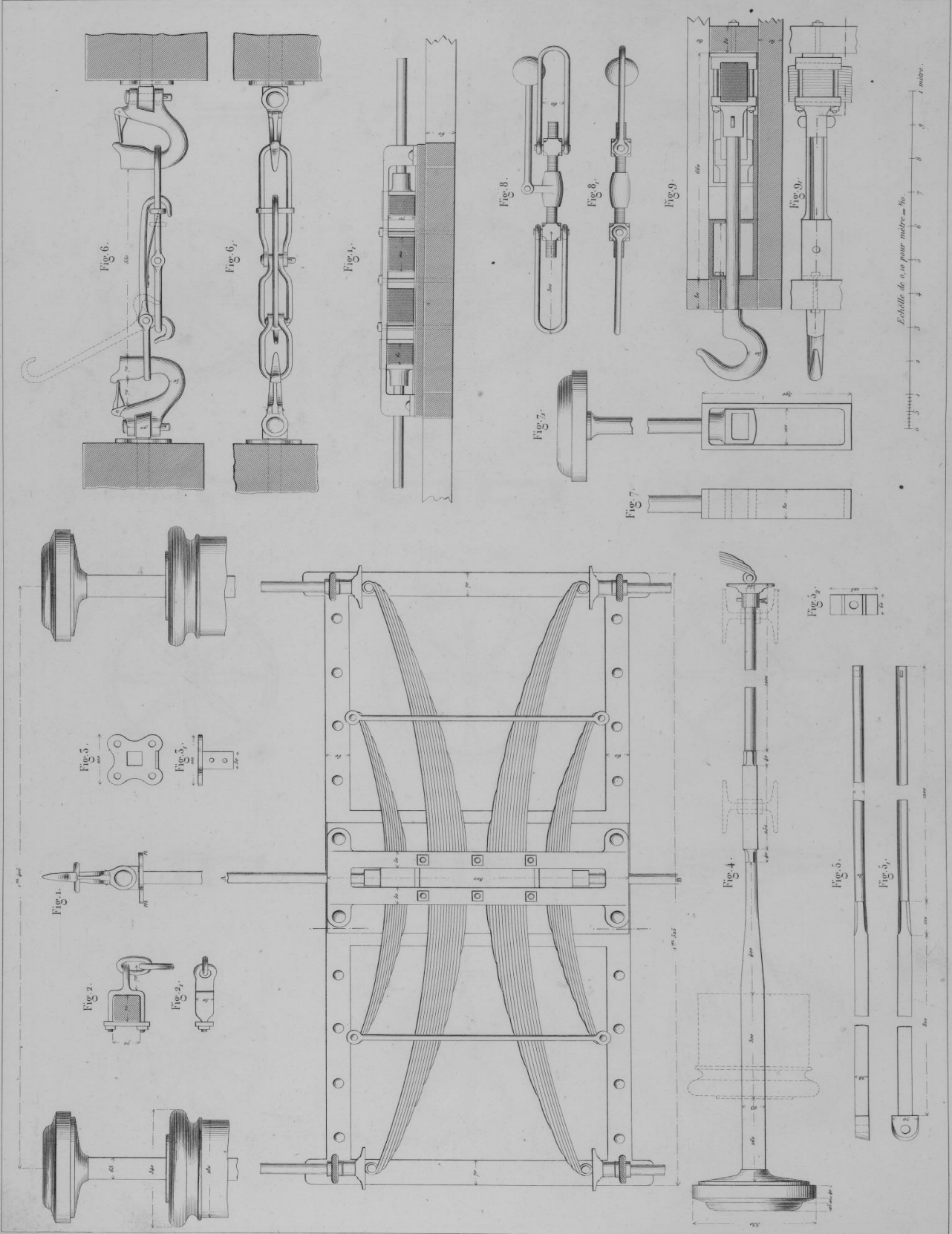

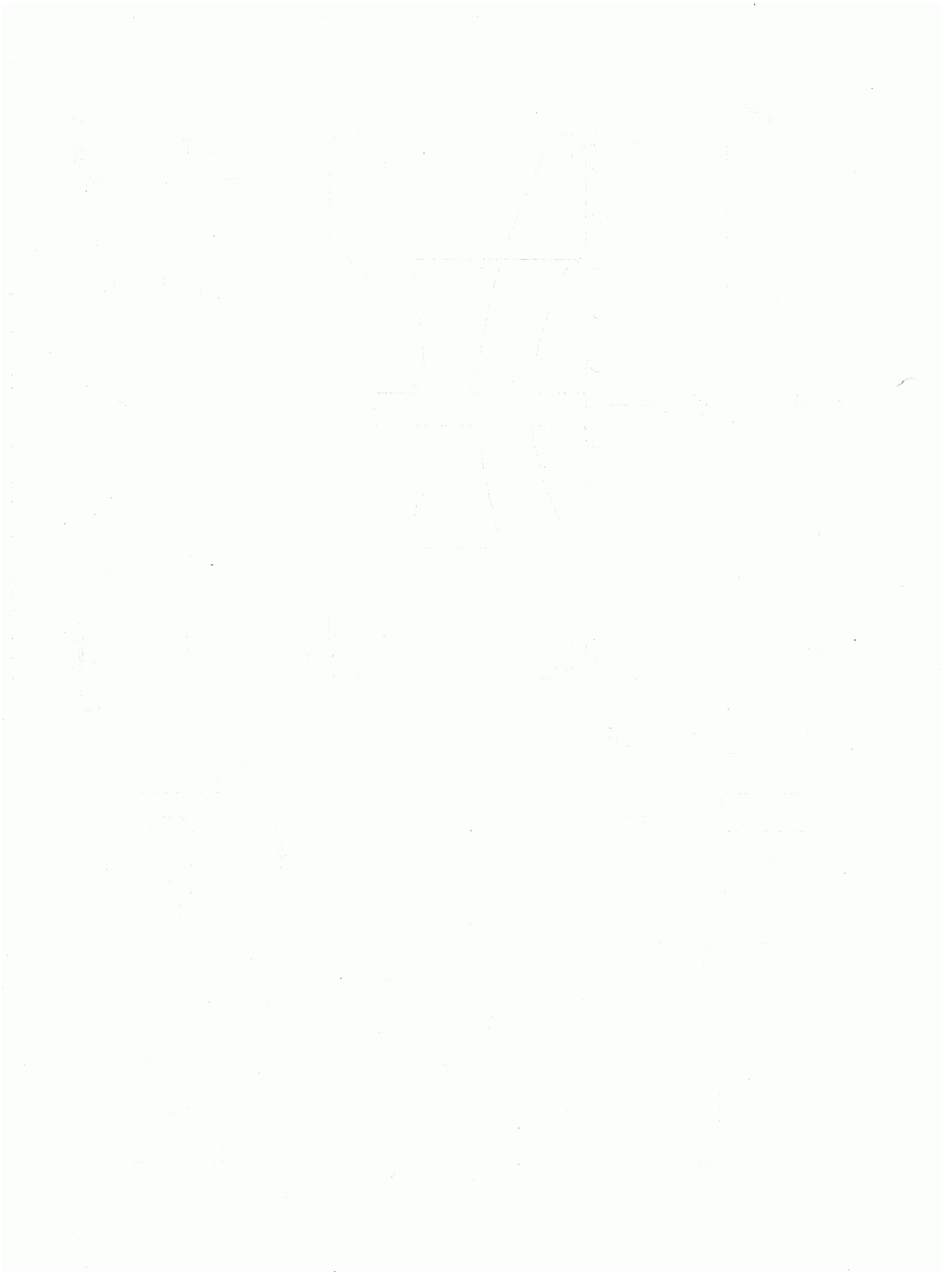

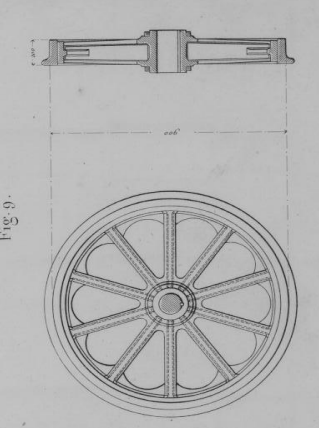
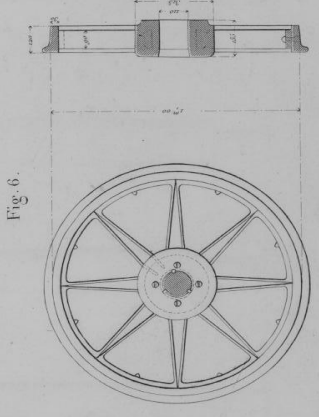
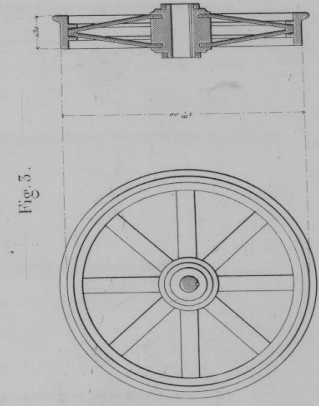
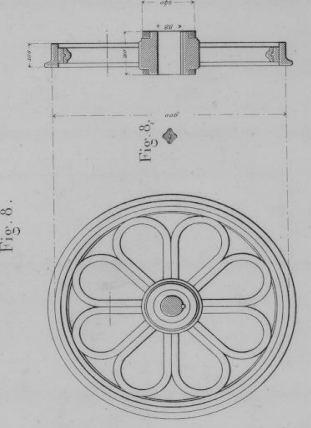
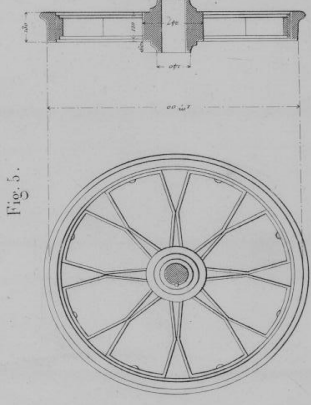
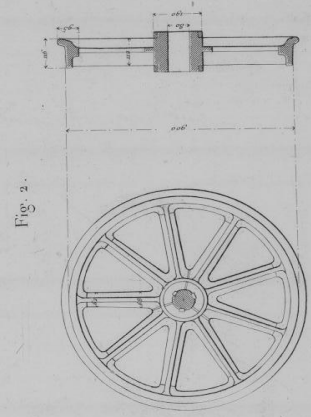
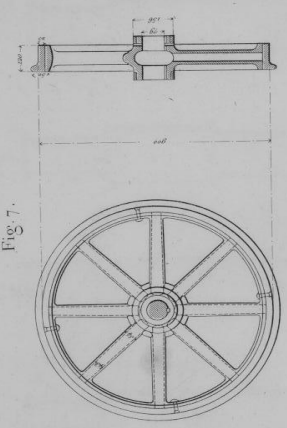
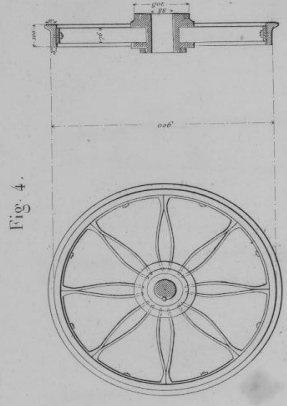
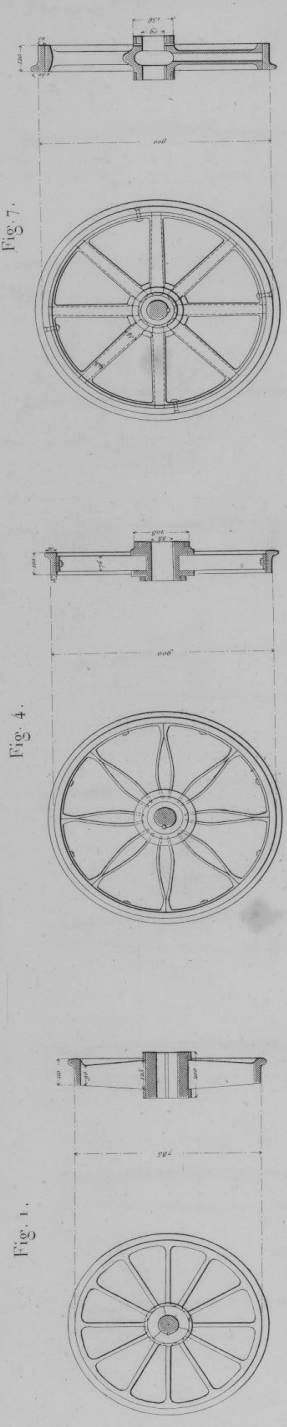

Echelle de 0,01 pour metre = 1/100.
1 2 3 4 5 6 7 8 9 10

© 2015 Cnam - Tous droits réservés

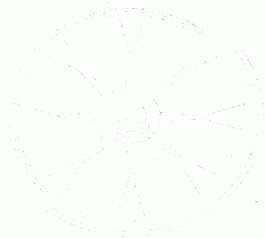

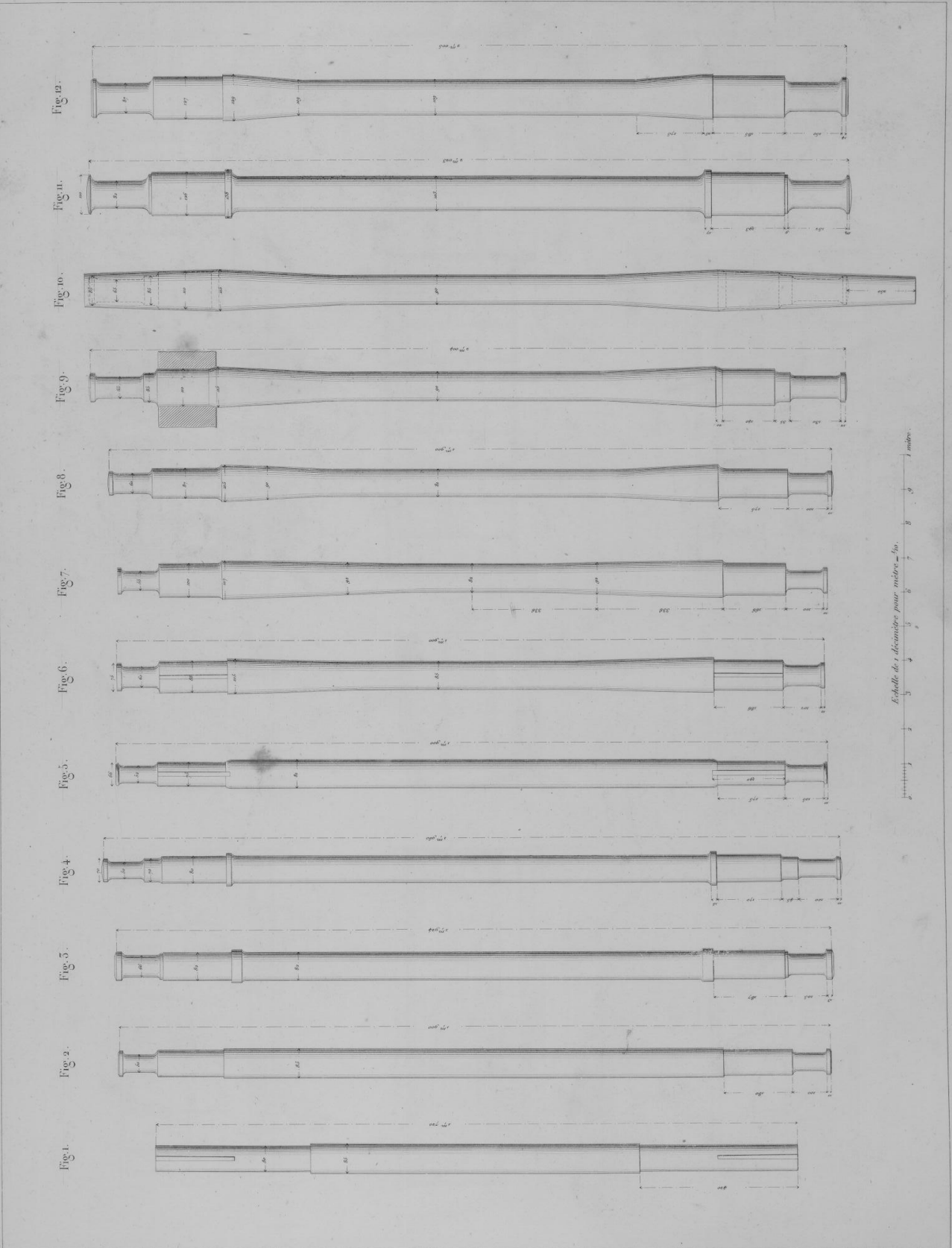

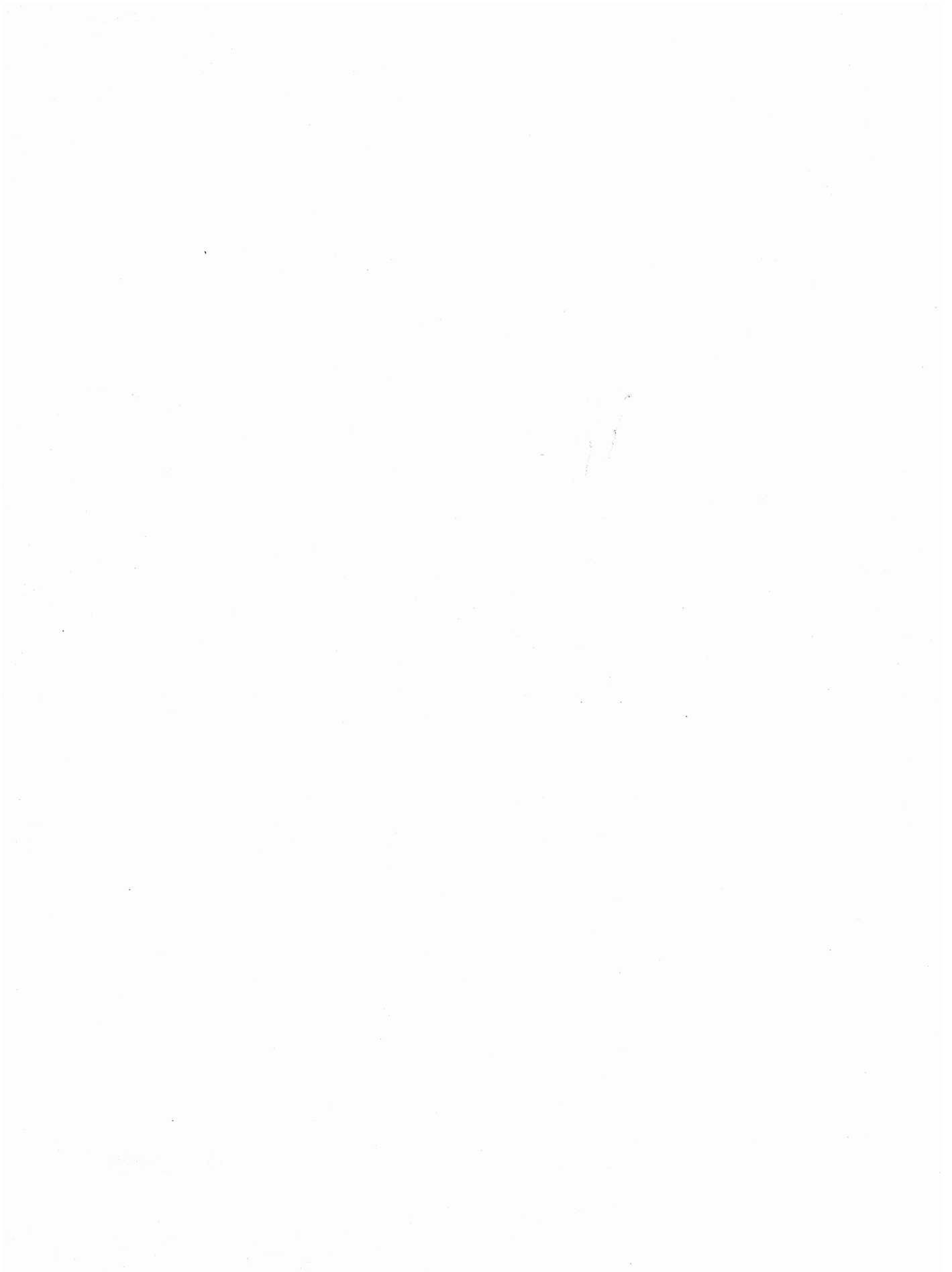

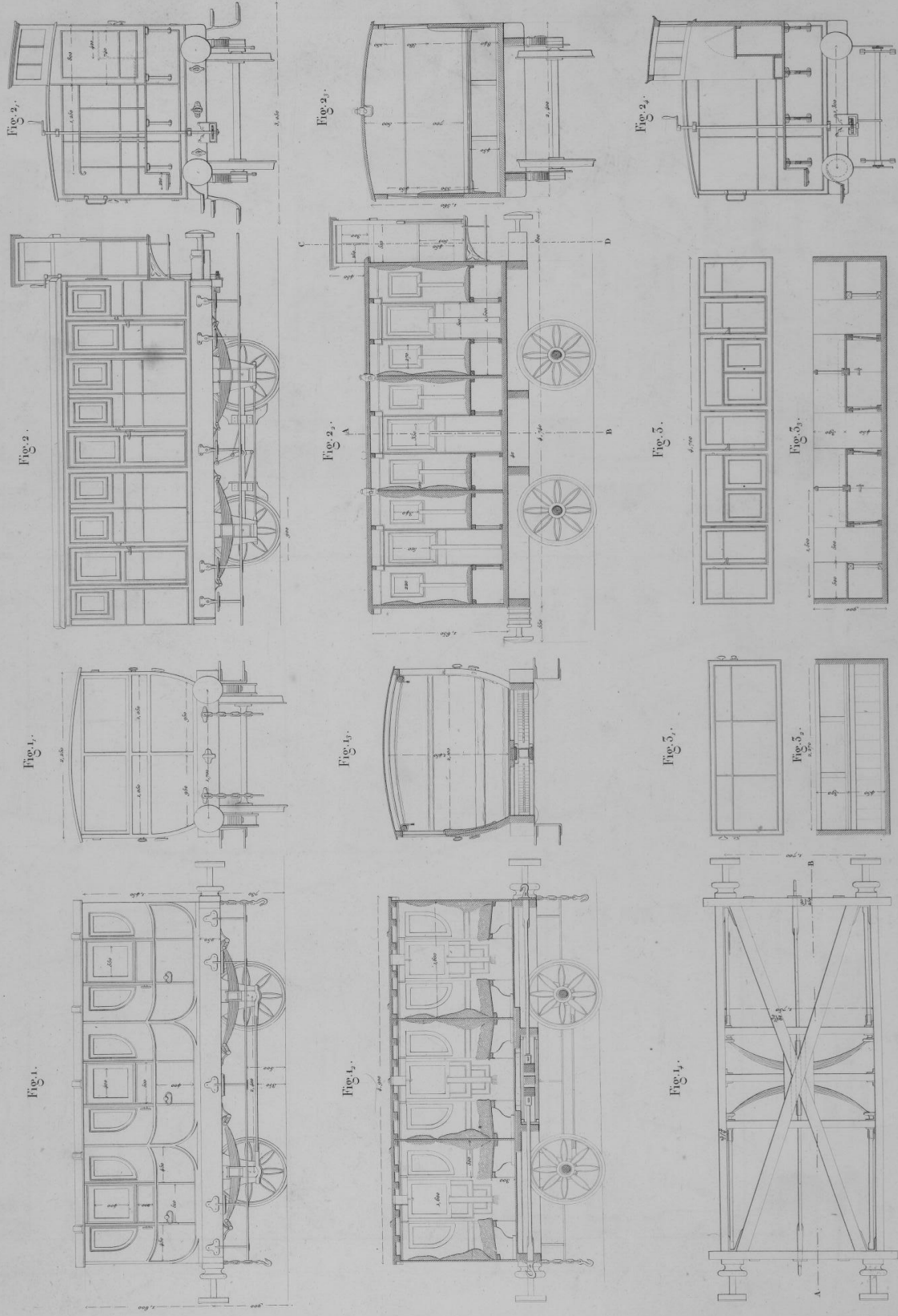

Echelle de 0,02 pour mètr. = 1/50.
0 1 2 3 4 5 mètr.

Détails du chassis des voitures du chemin de Paris à Rouen.

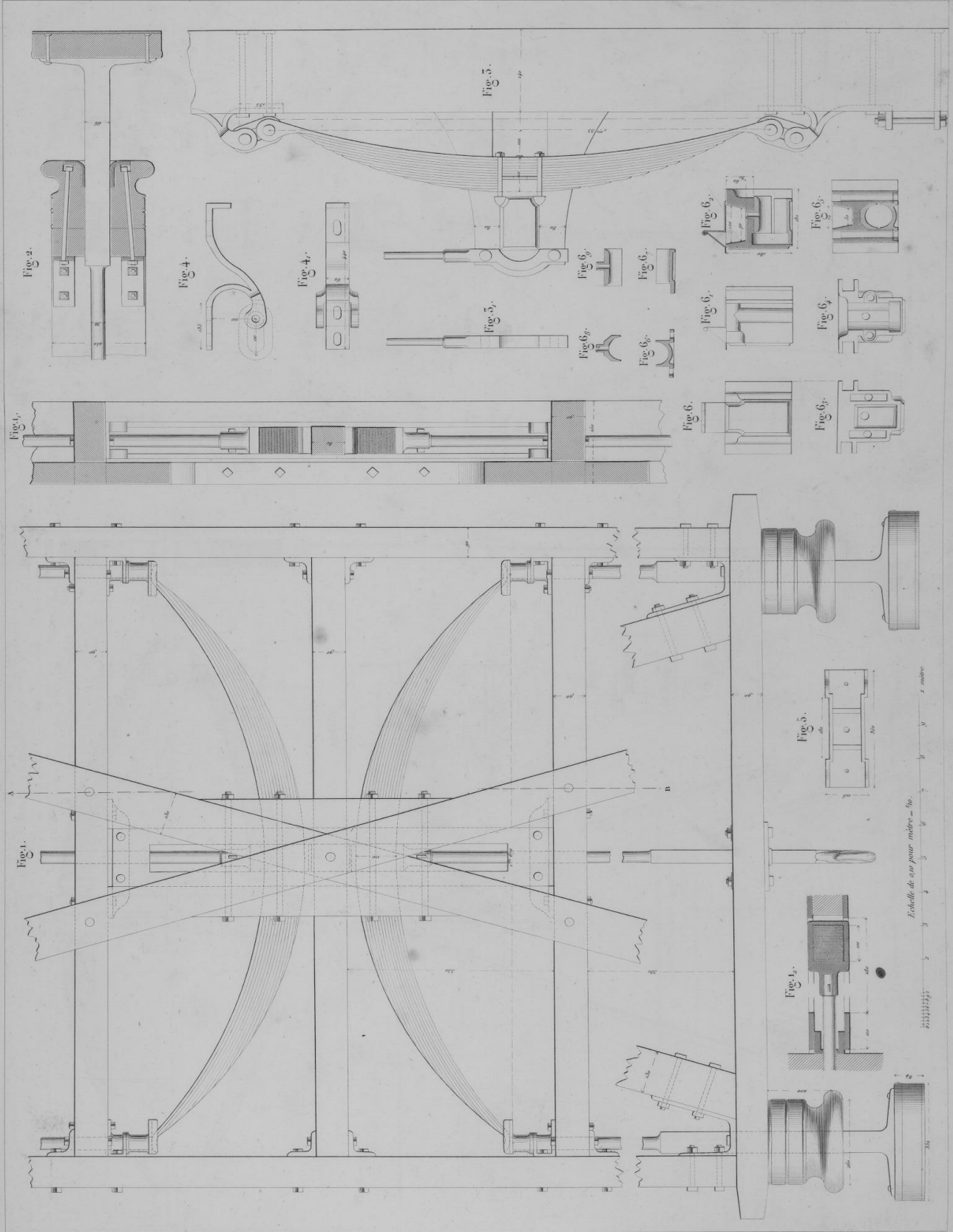

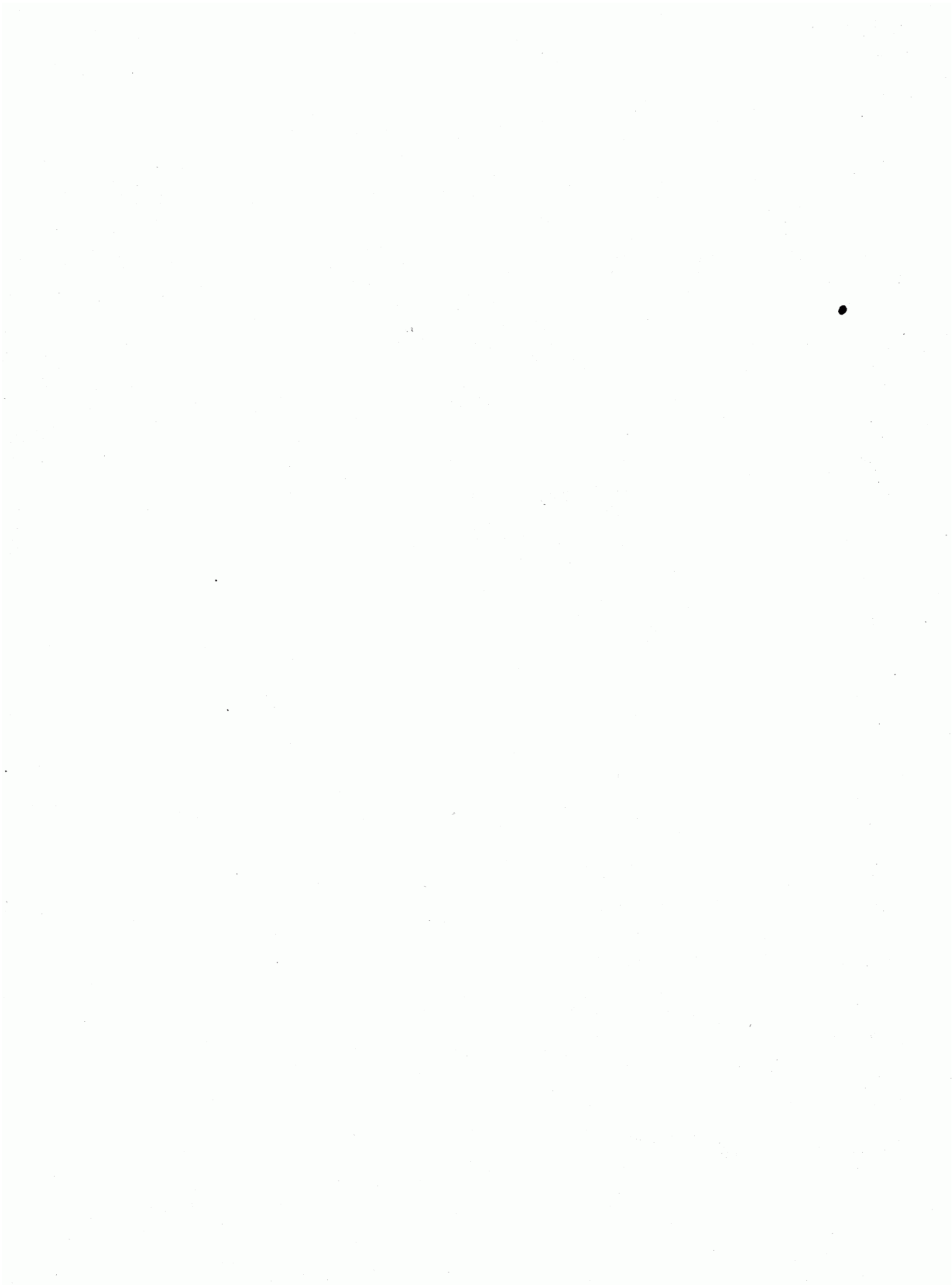

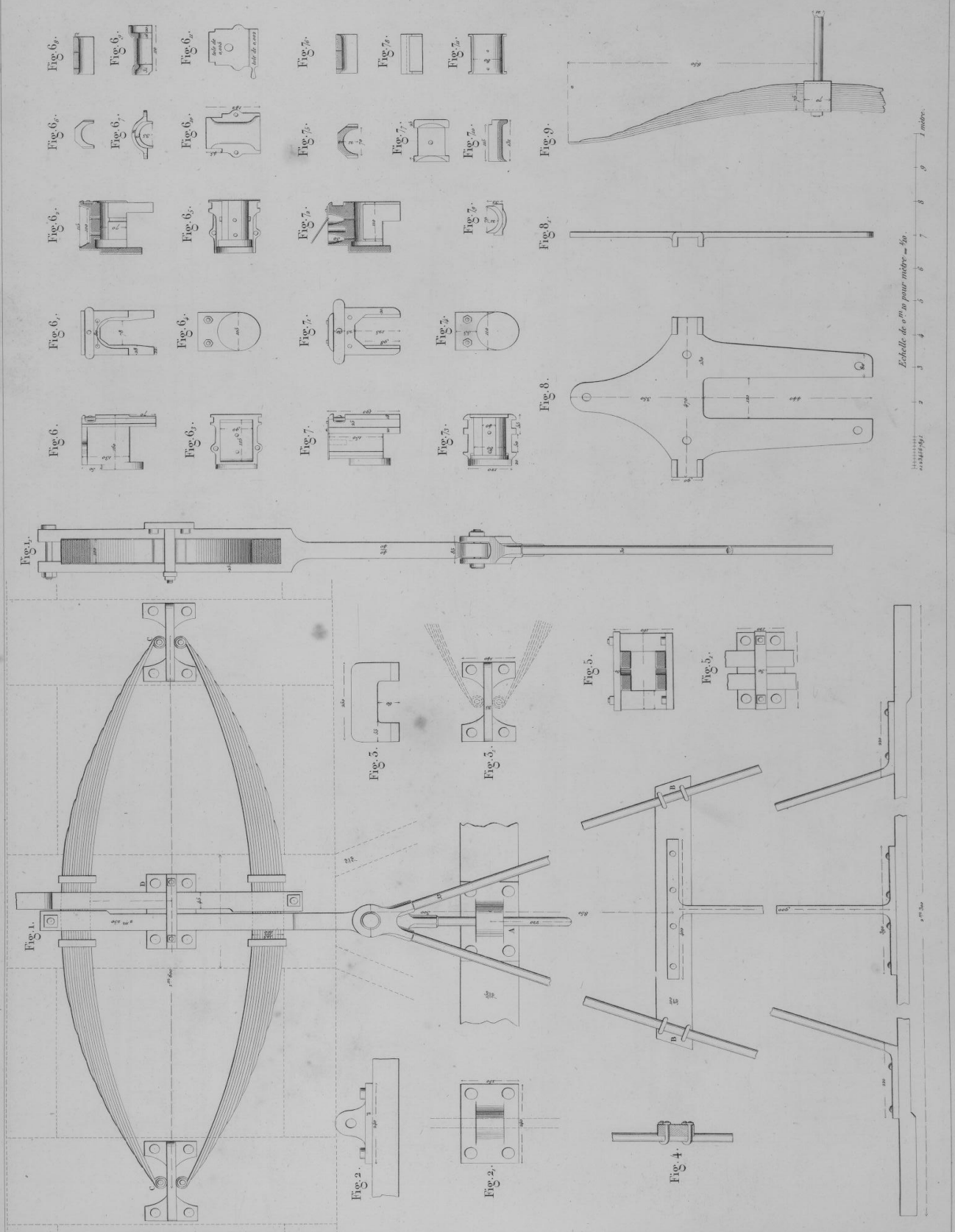

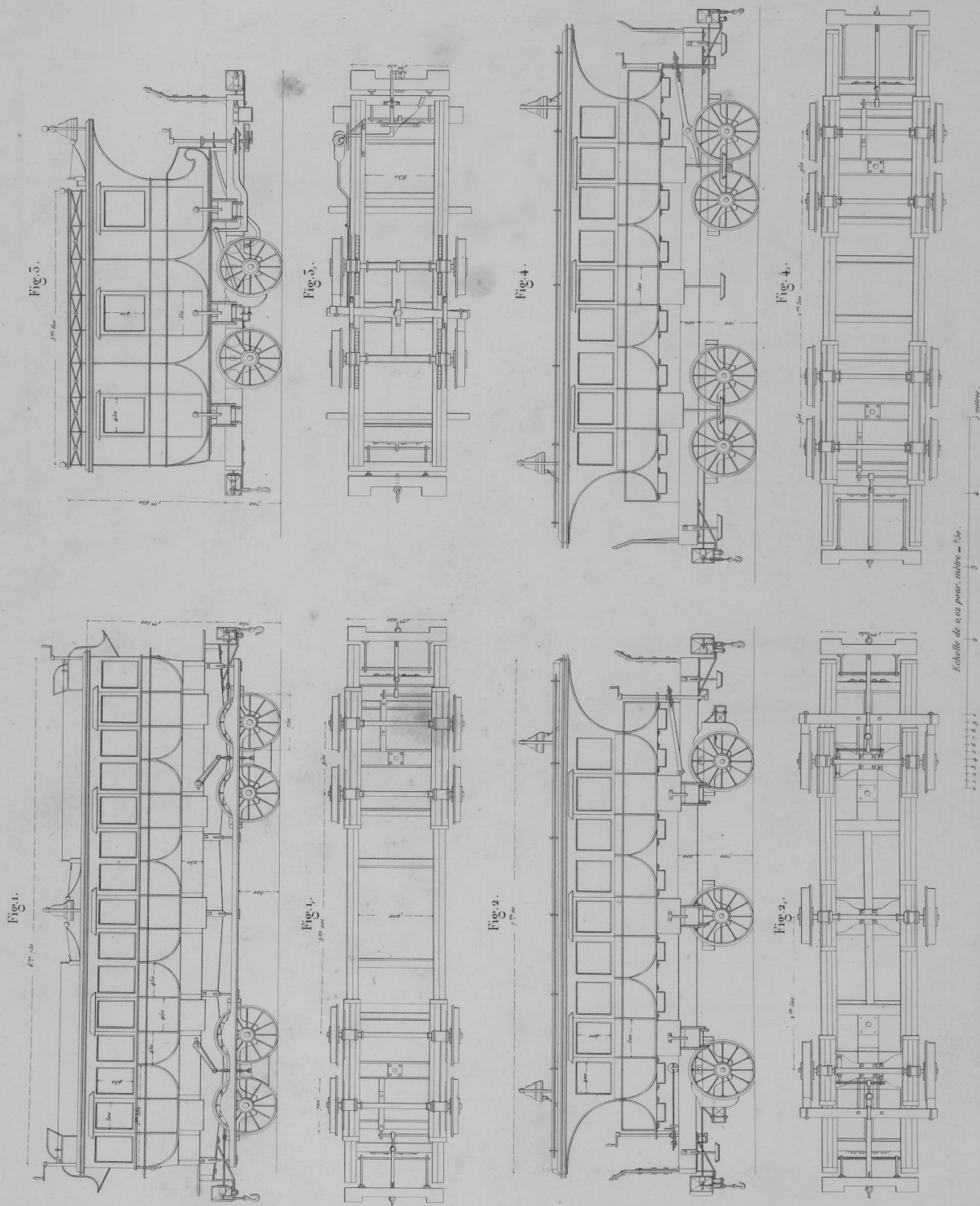

Détails des voitures du chemin de S^t Etienne à Lyon.

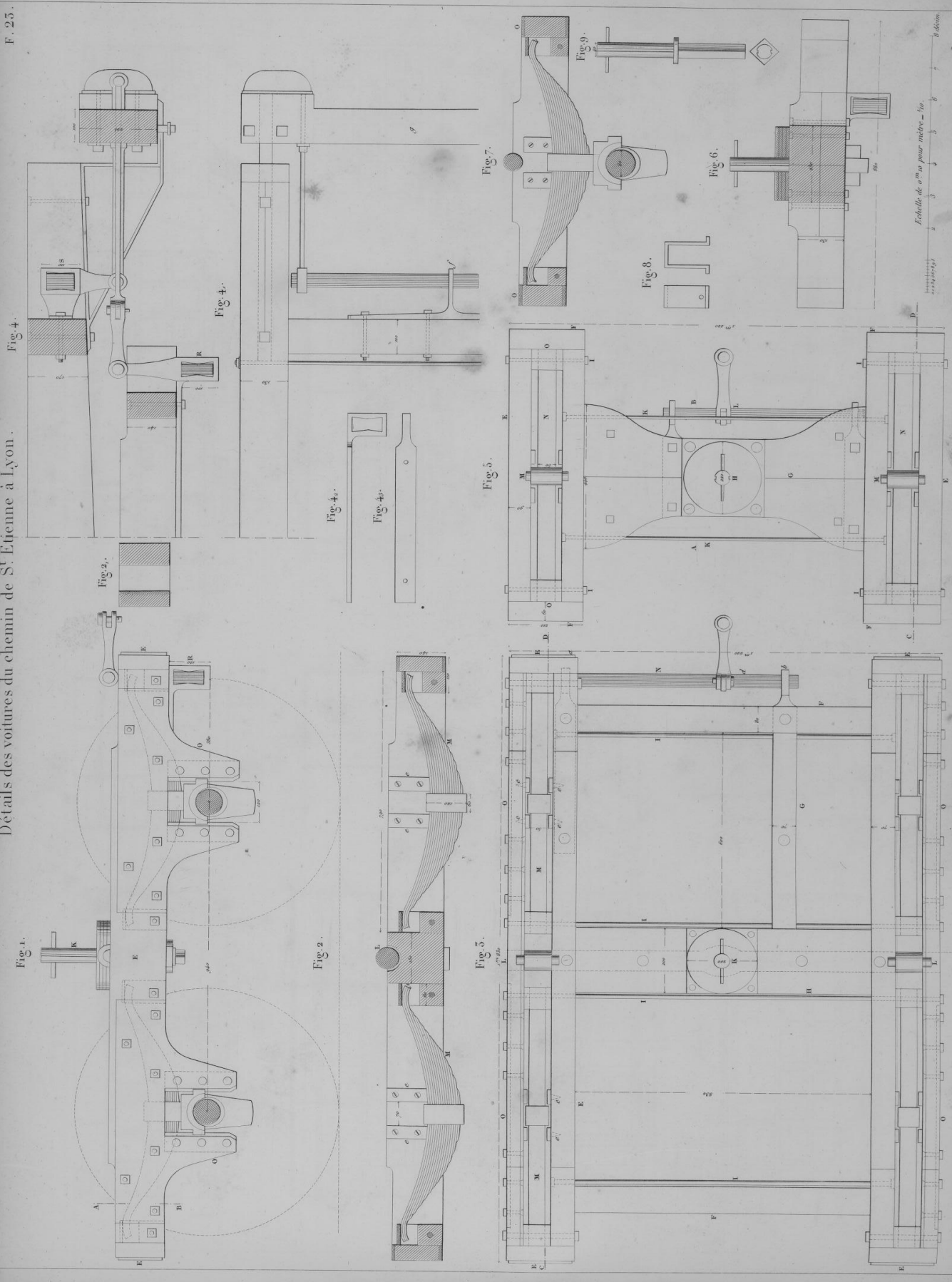

Échelle de 0^m.10 pour maître-voiture
0 1 2 3 4 5 6 7 8 9 10
8 decim.

Fig. 1.

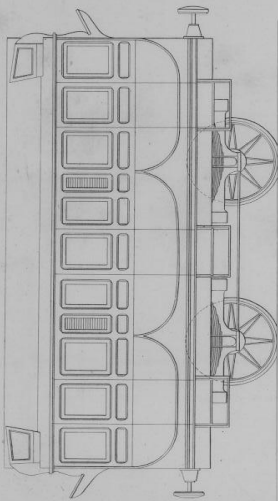

Fig. 1.

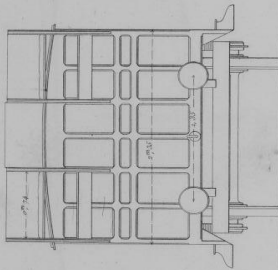

Fig. 2.

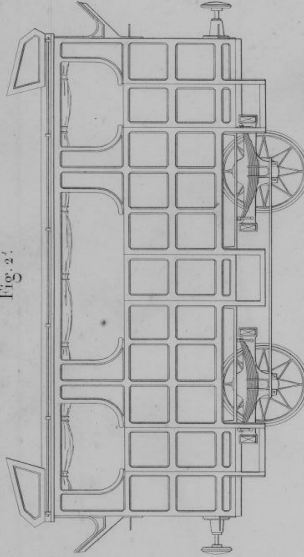

Fig. 2.

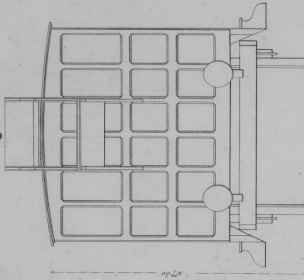

Fig. 1.

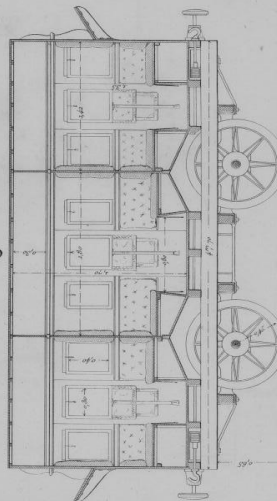

Fig. 1.

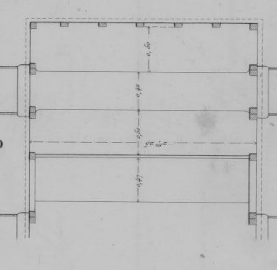

Fig. 3.

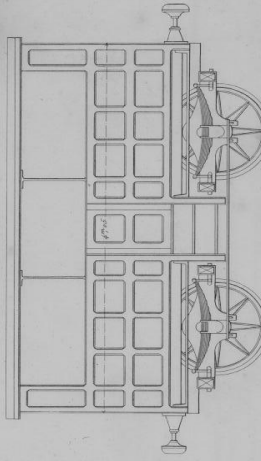

Fig. 3.

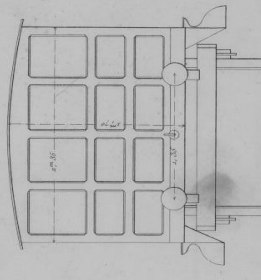

Fig. 1.

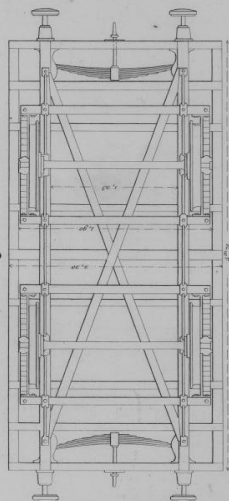

Fig. 4.

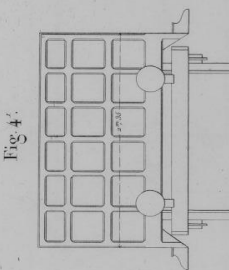

Fig. 4.

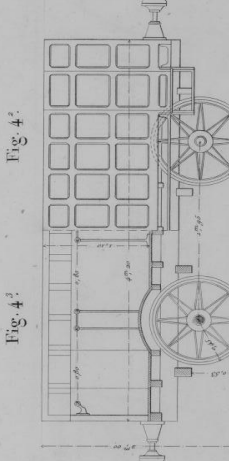

Fig. 5.

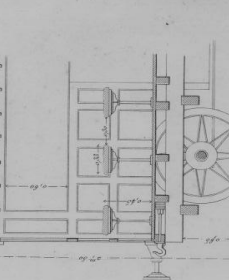

Fig. 5.

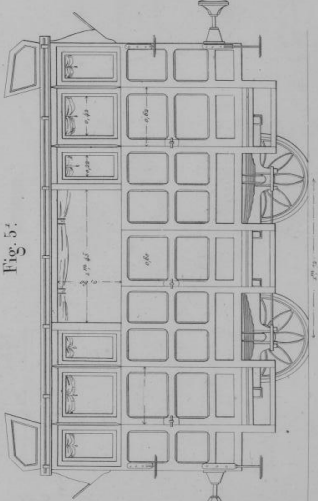

Fig. 5.

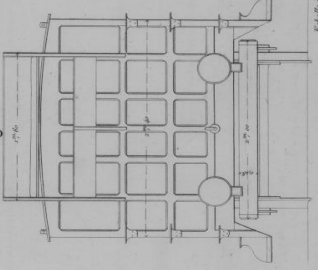

Fig. 5.

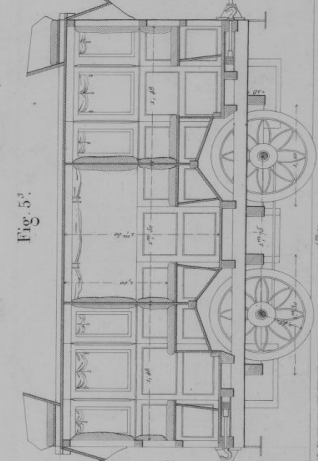
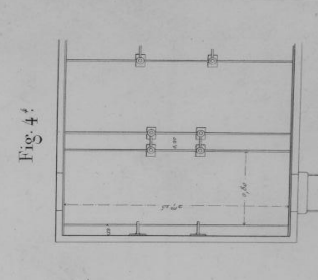

Fig. 4.



Echelle de proportions = 1/50.

millim.

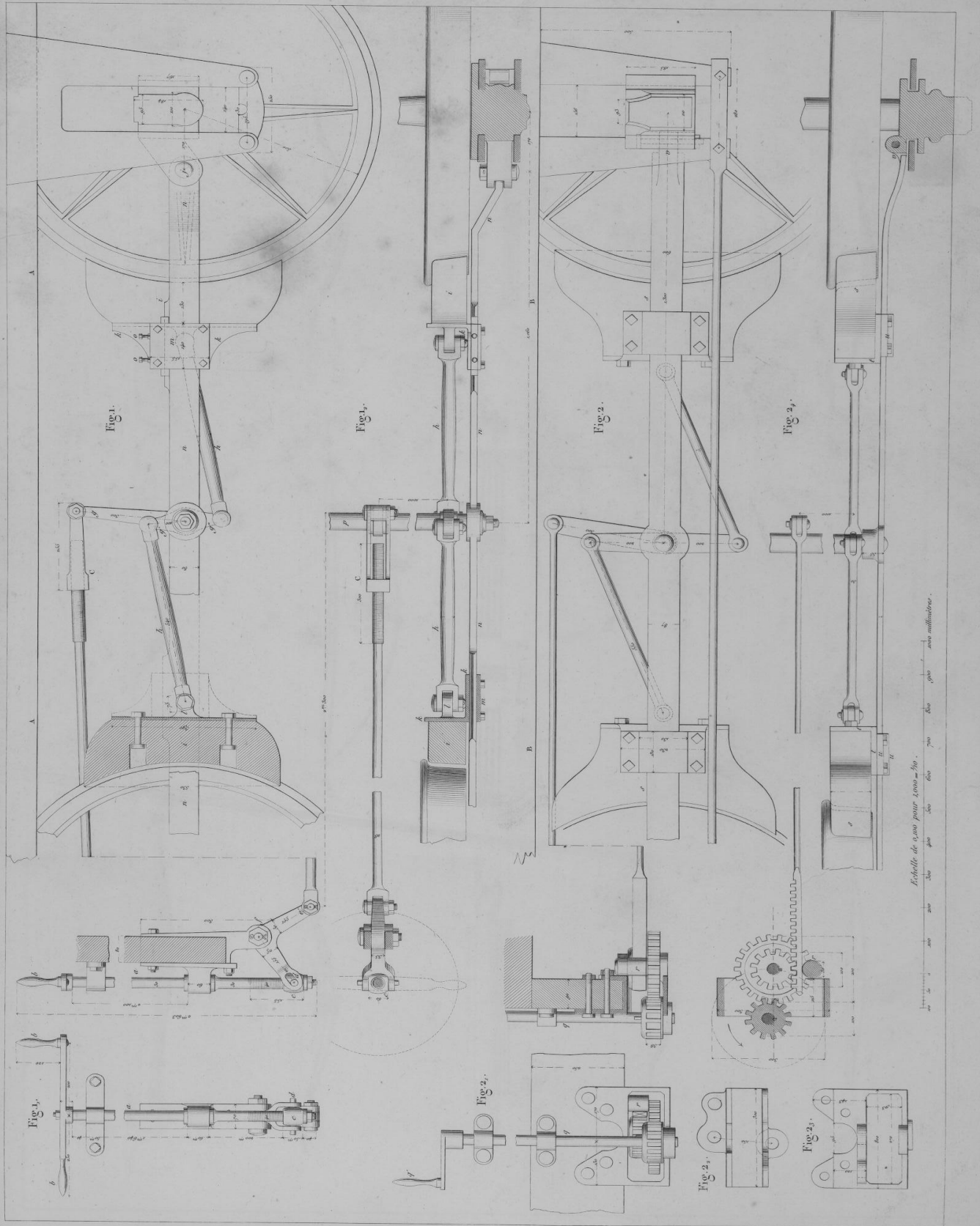

Fig. 1.



Fig. 2.



Fig. 3.



Fig. 4.



Fig. 5.

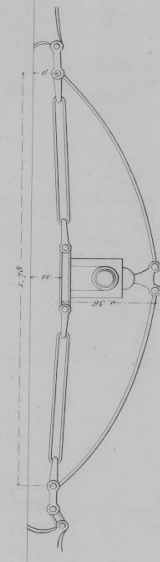

Fig. 6.



Fig. 7.



Fig. 8.

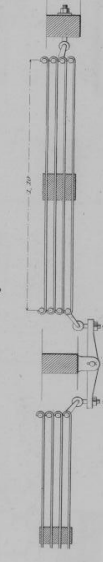

Fig. 9.



Fig. 10.



Fig. 11.



Fig. 12.



Fig. 13.



Fig. 14.

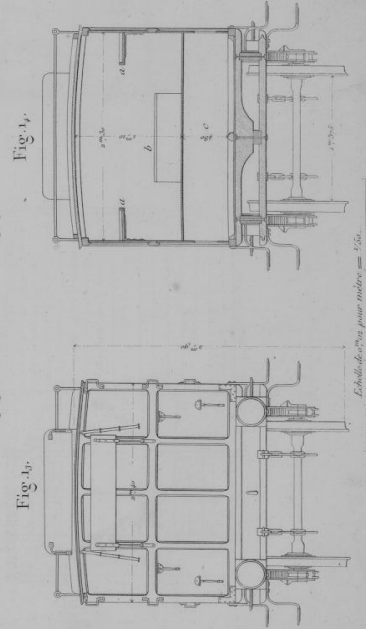
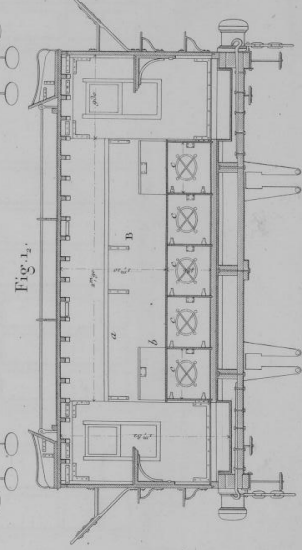
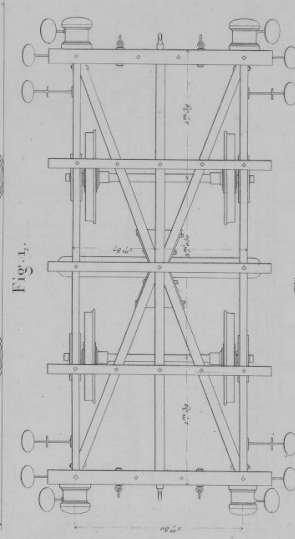
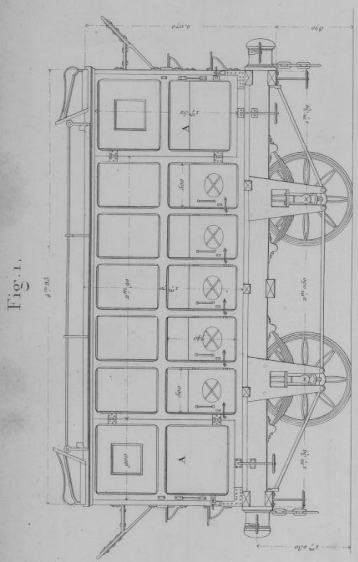
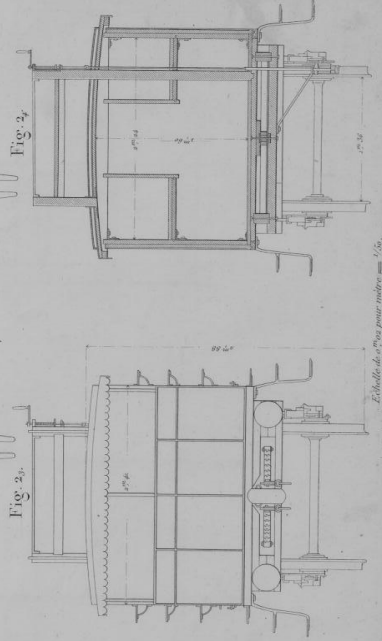
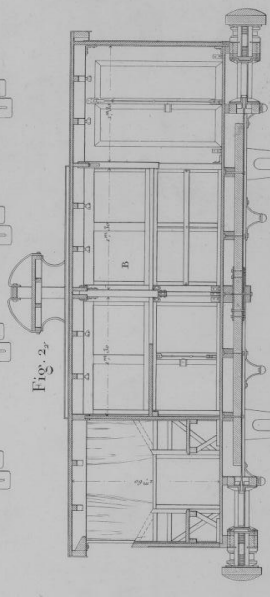
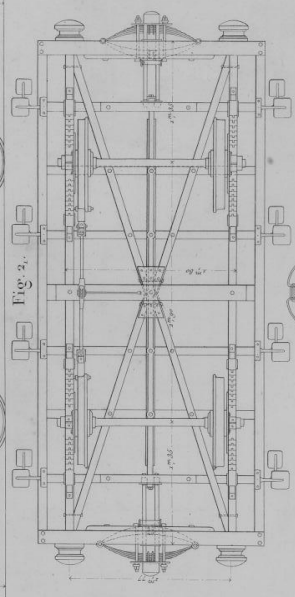
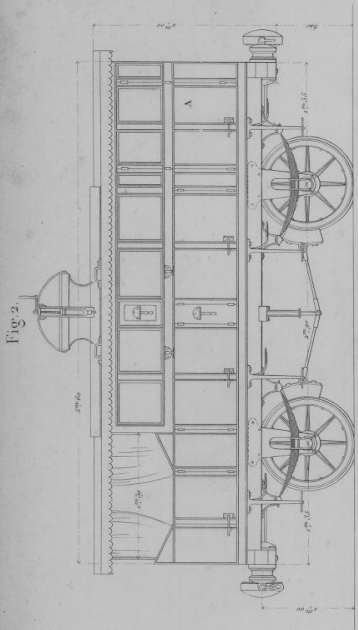

Fig. 15.



Échelle de 0,0105 pour mètre 50.





Échelle de 0,001 m pour toutes les figures.
 G. T. Blanc sculpteur.
 Paris, Muller et Herriot.

Vagons divers pour transport de voitures et de marchandises.

G. 2.

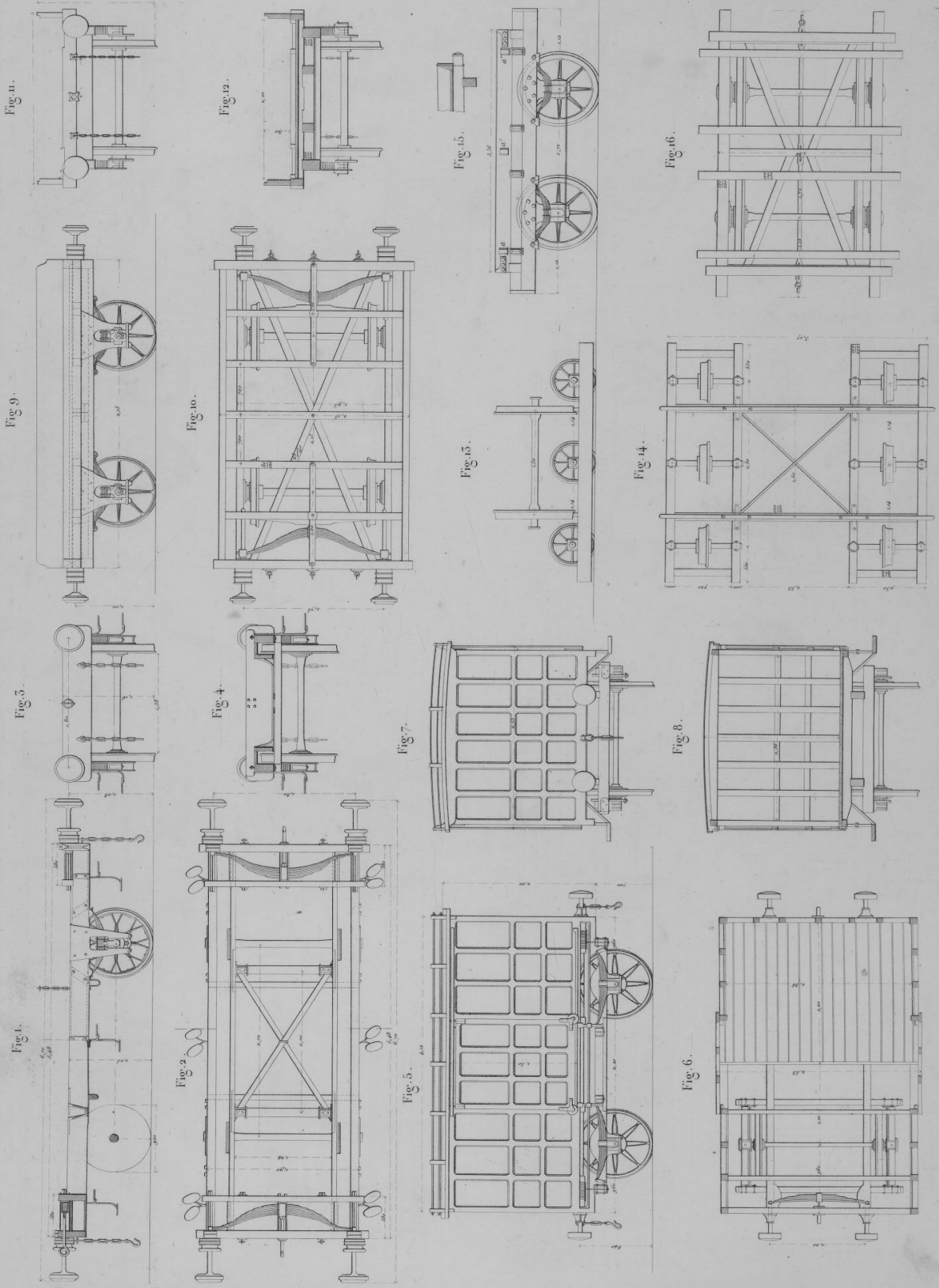

Échelle de 0,02 pour mètres. 1/2

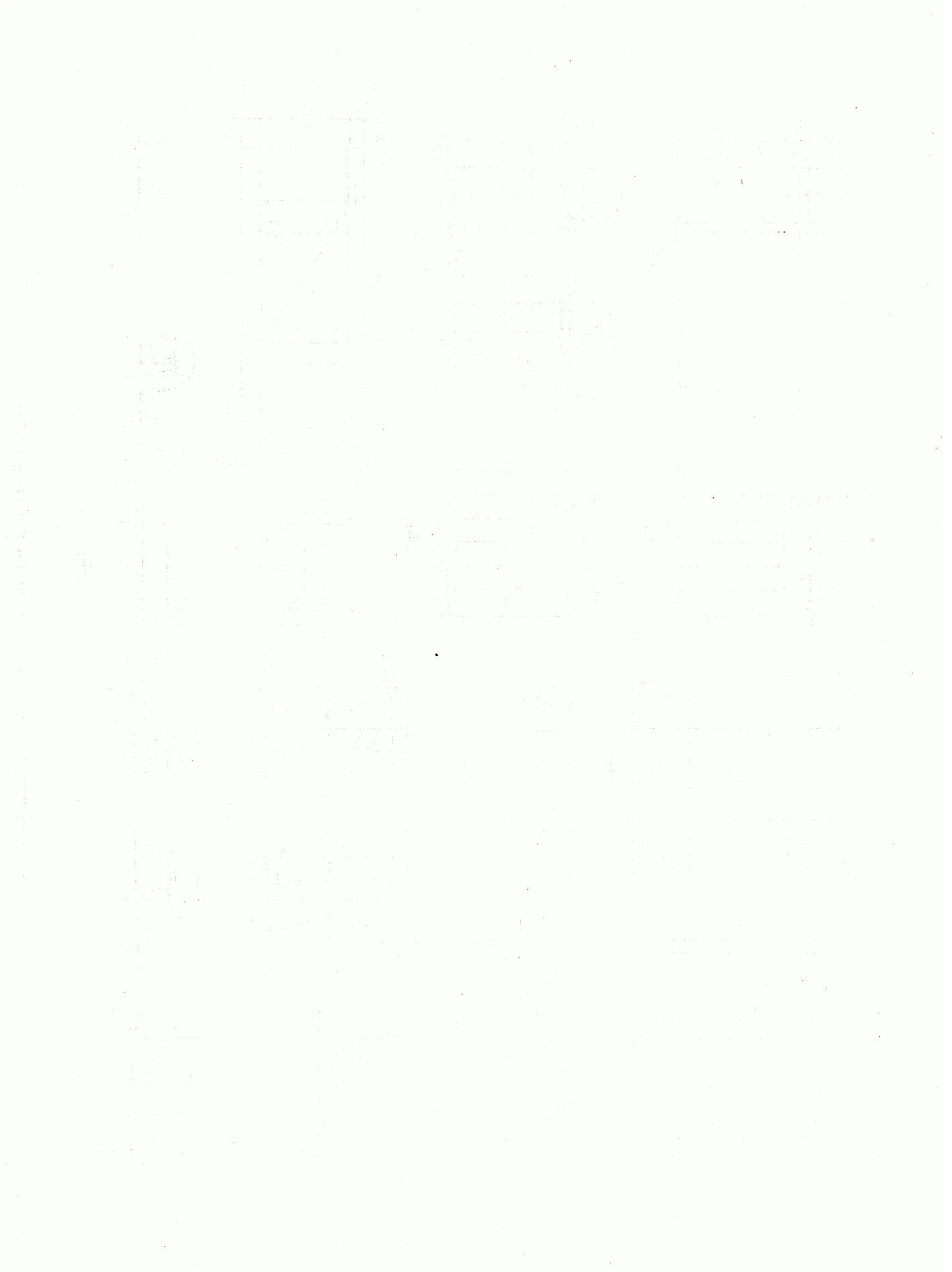

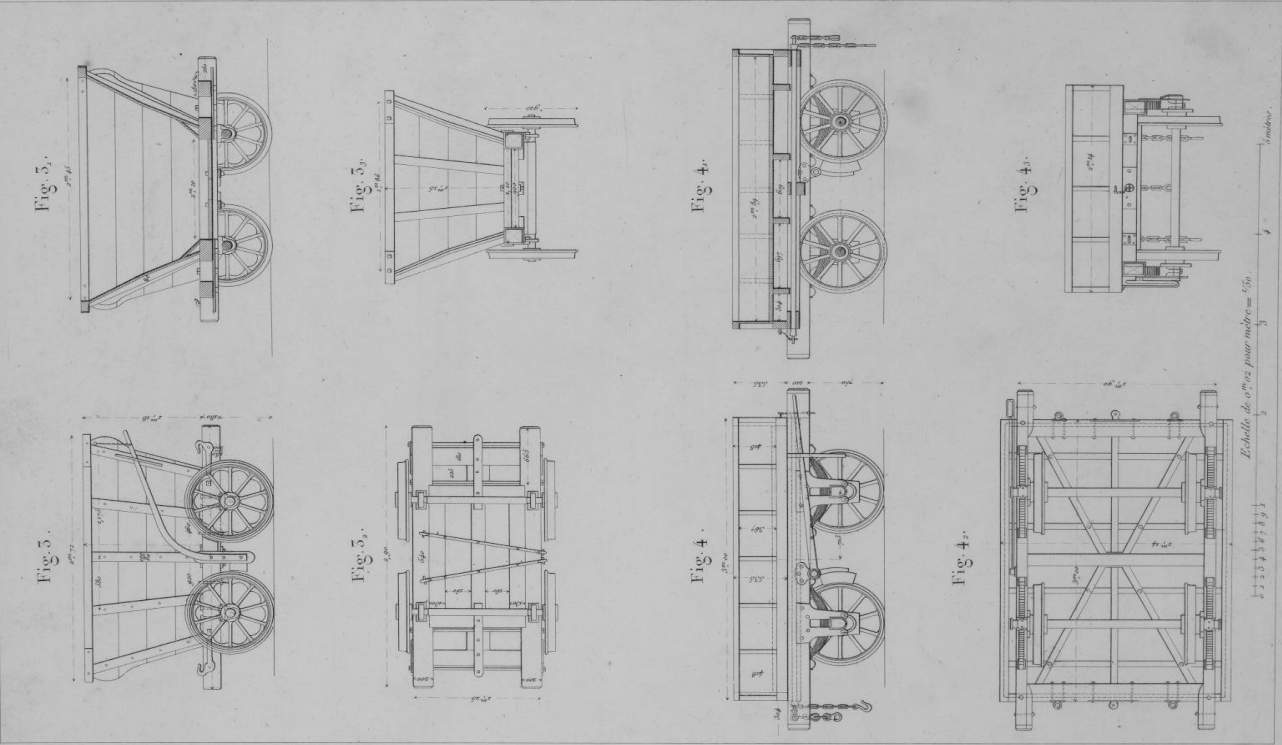
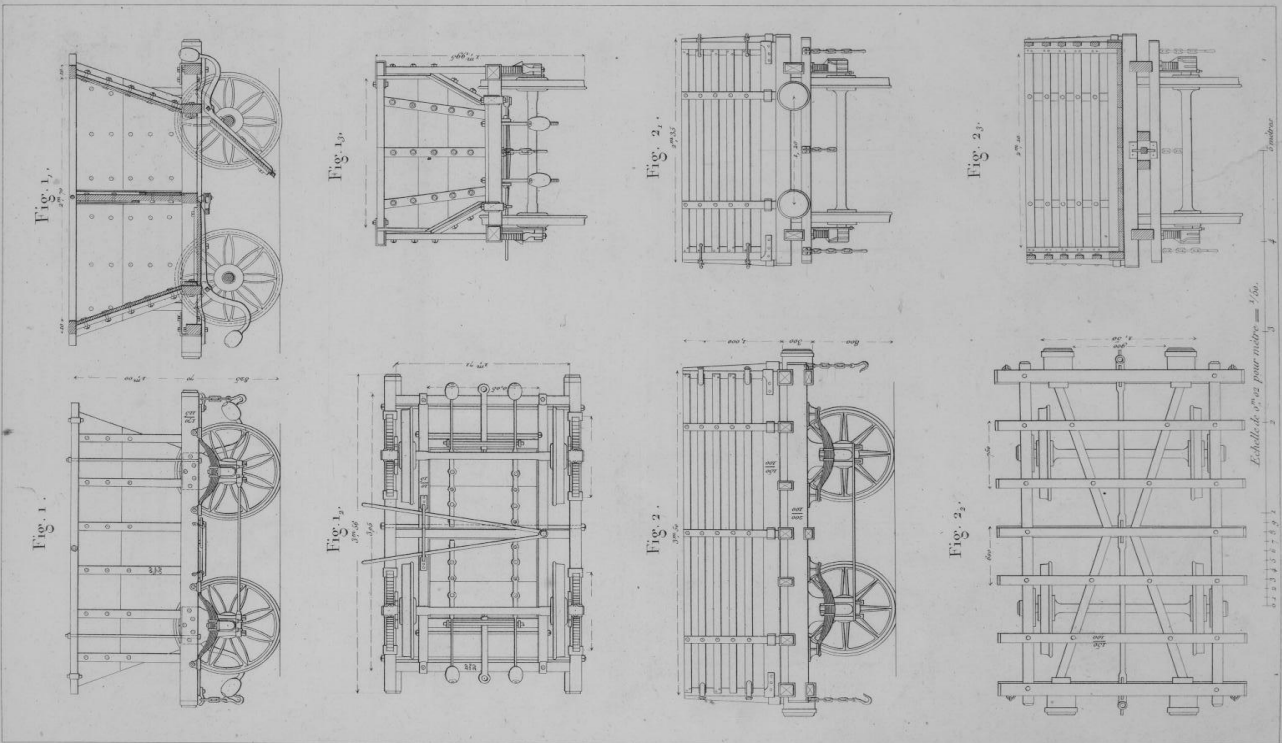

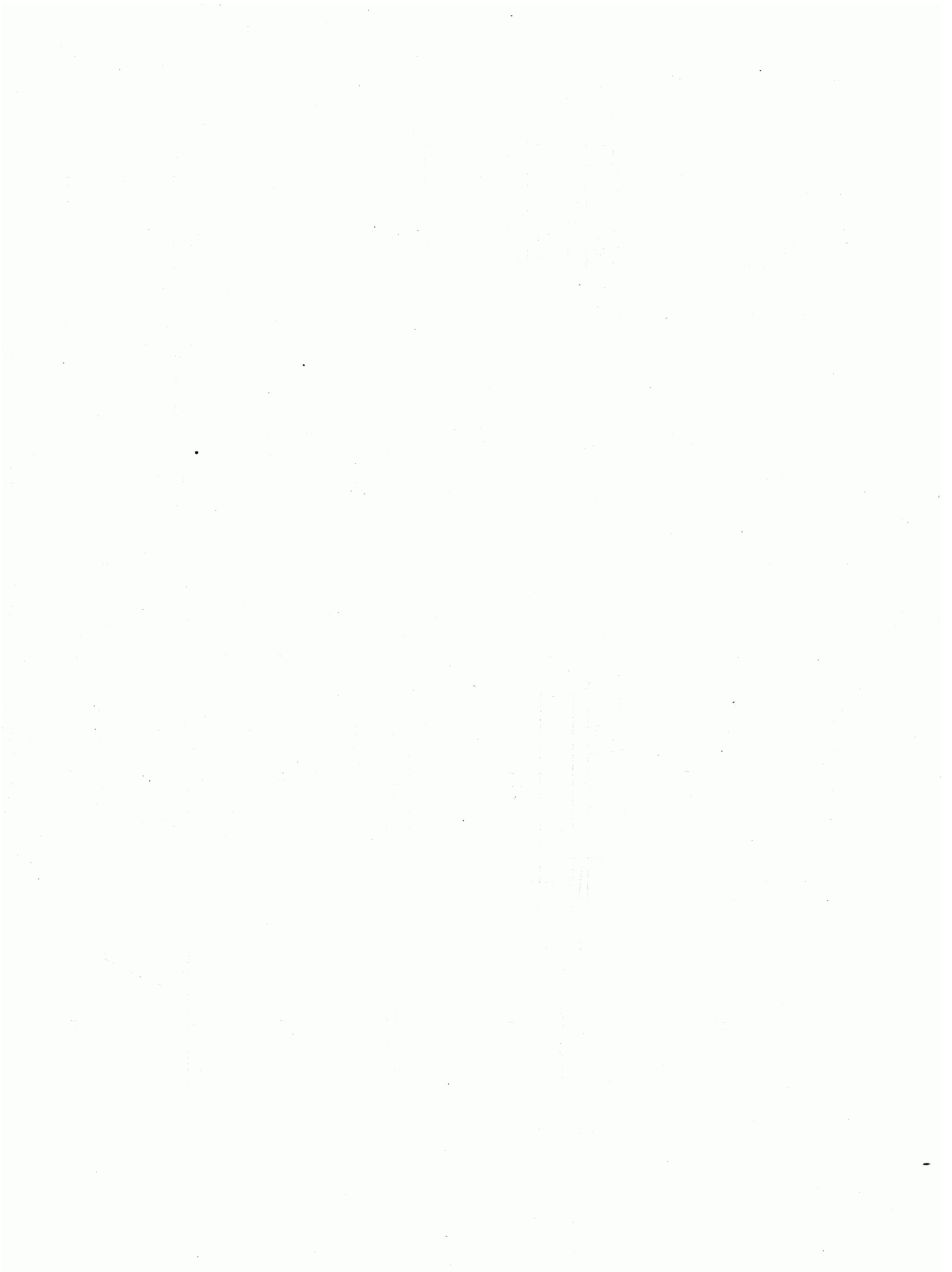

Wagon à huit roues pour le transport des marchandises du chemin de Strasbourg à Bâle.

G. 4.

Fig. 1.

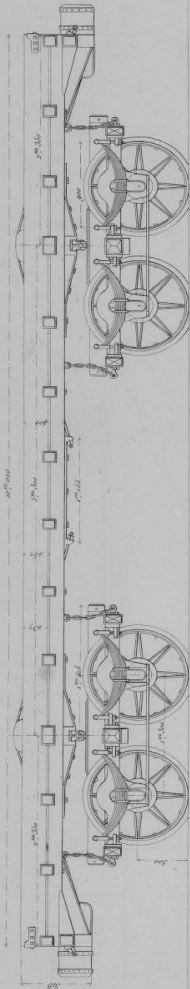

Fig. 2.

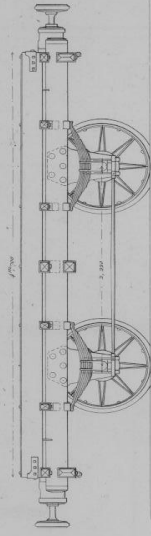

Fig. 1.

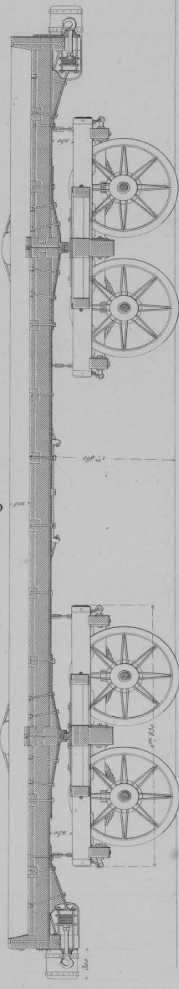

Fig. 2.

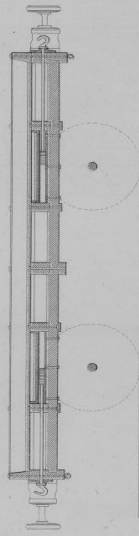

Fig. 1.

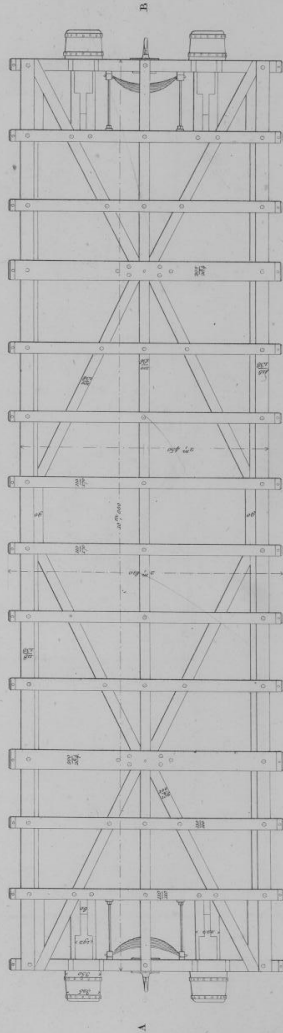

Fig. 2.

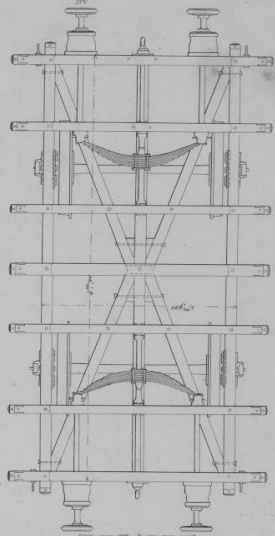

Fig. 1.

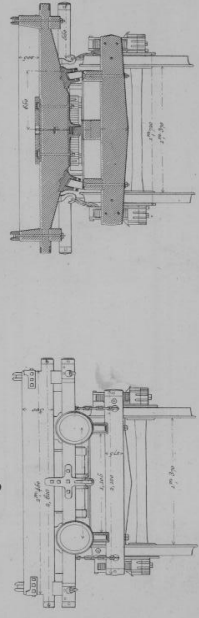

Fig. 1.

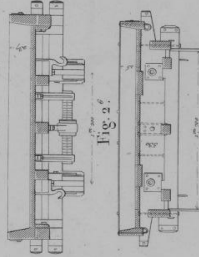

Fig. 2.

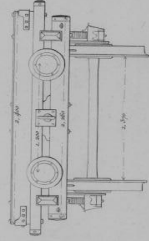
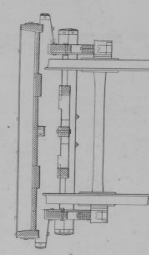
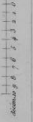

Fig. 2.



Echelle de 0^m 50 pour 1 mètre = 1/20.





Détails de la charpente du wagon à marchandises à quatre roues de Bâle à Strasbourg.

G. 6.

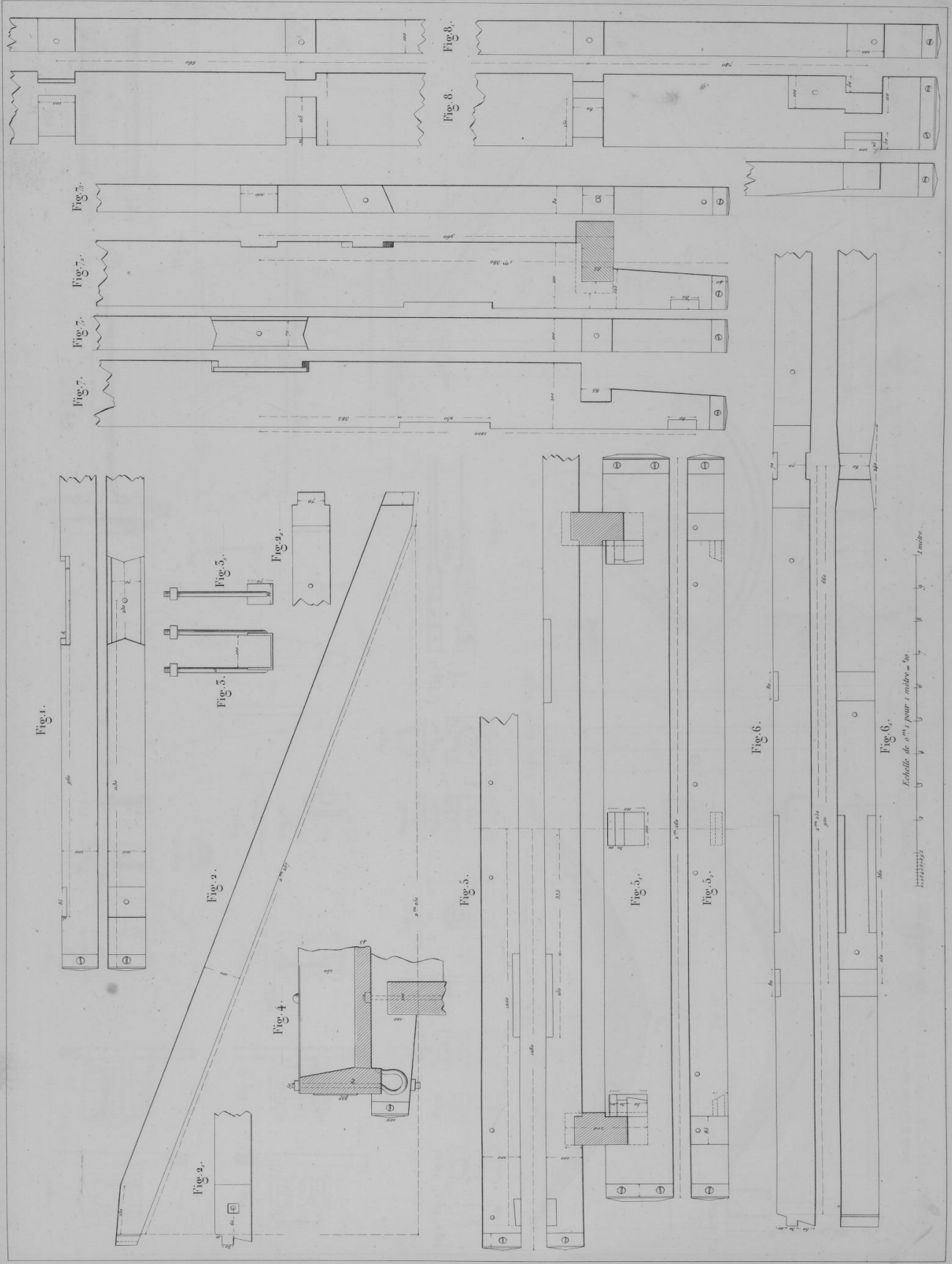



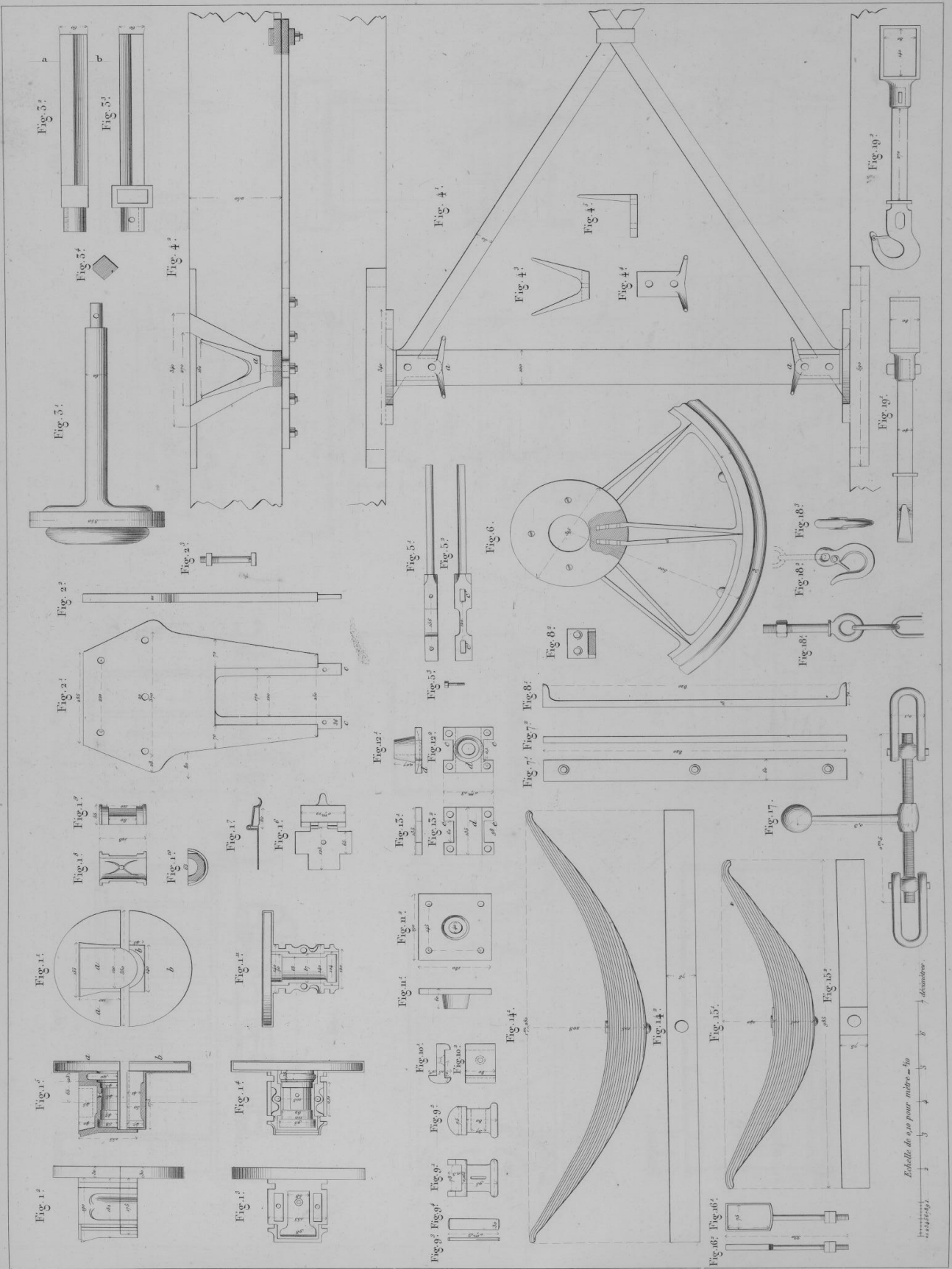

Vagons à bagages, à marchandises et à lait du chemin de fer de Paris à Rouen.

G. 8.

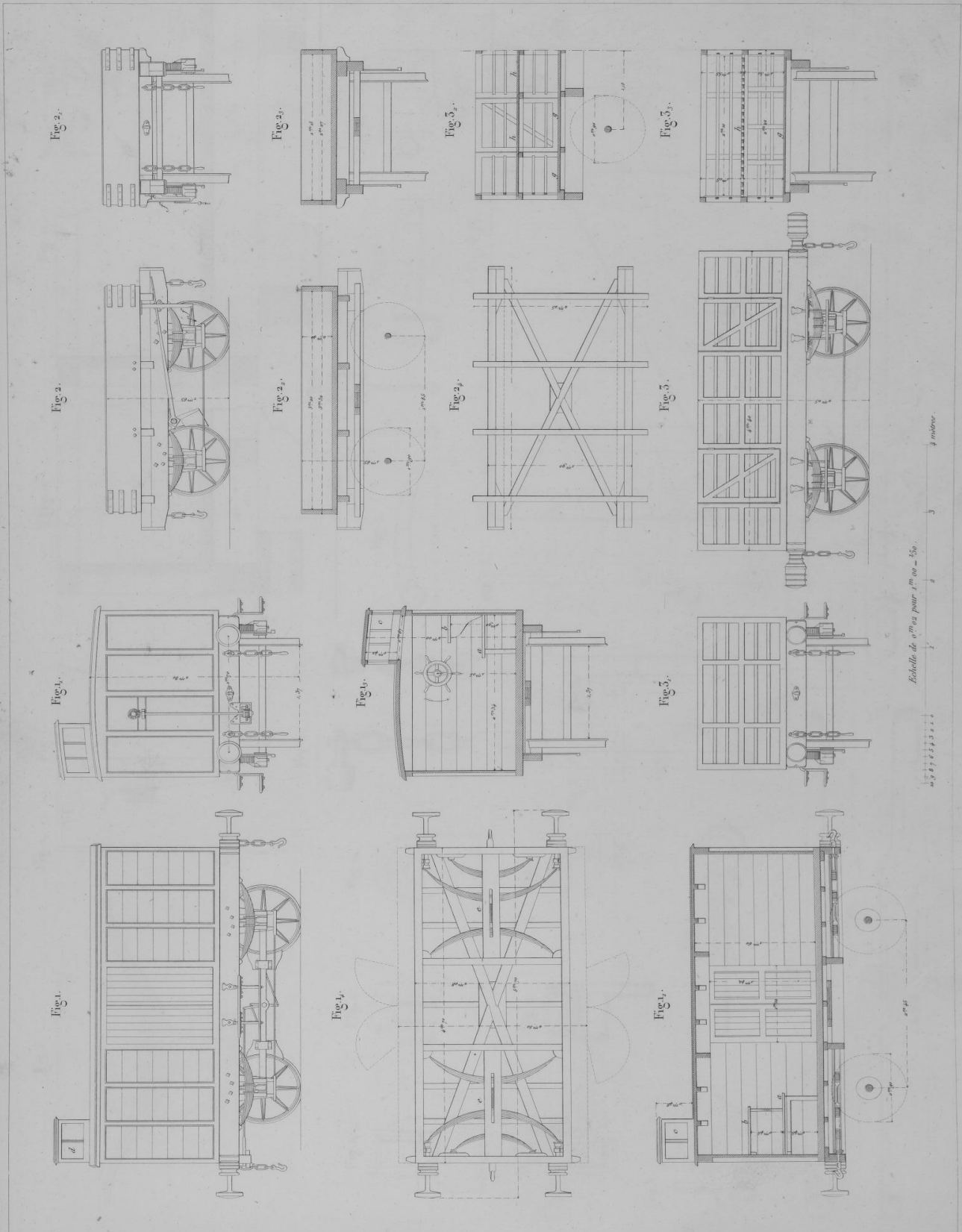



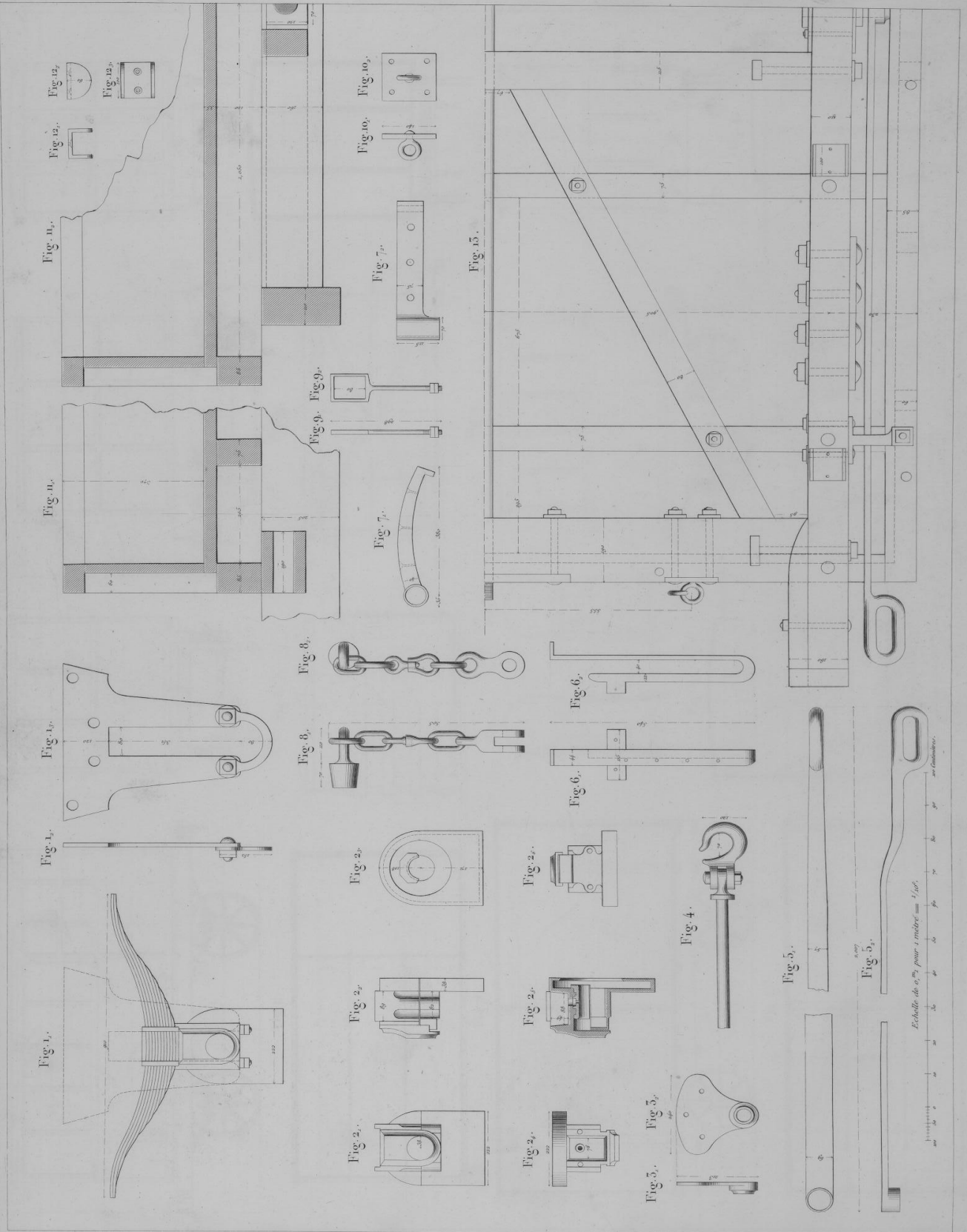

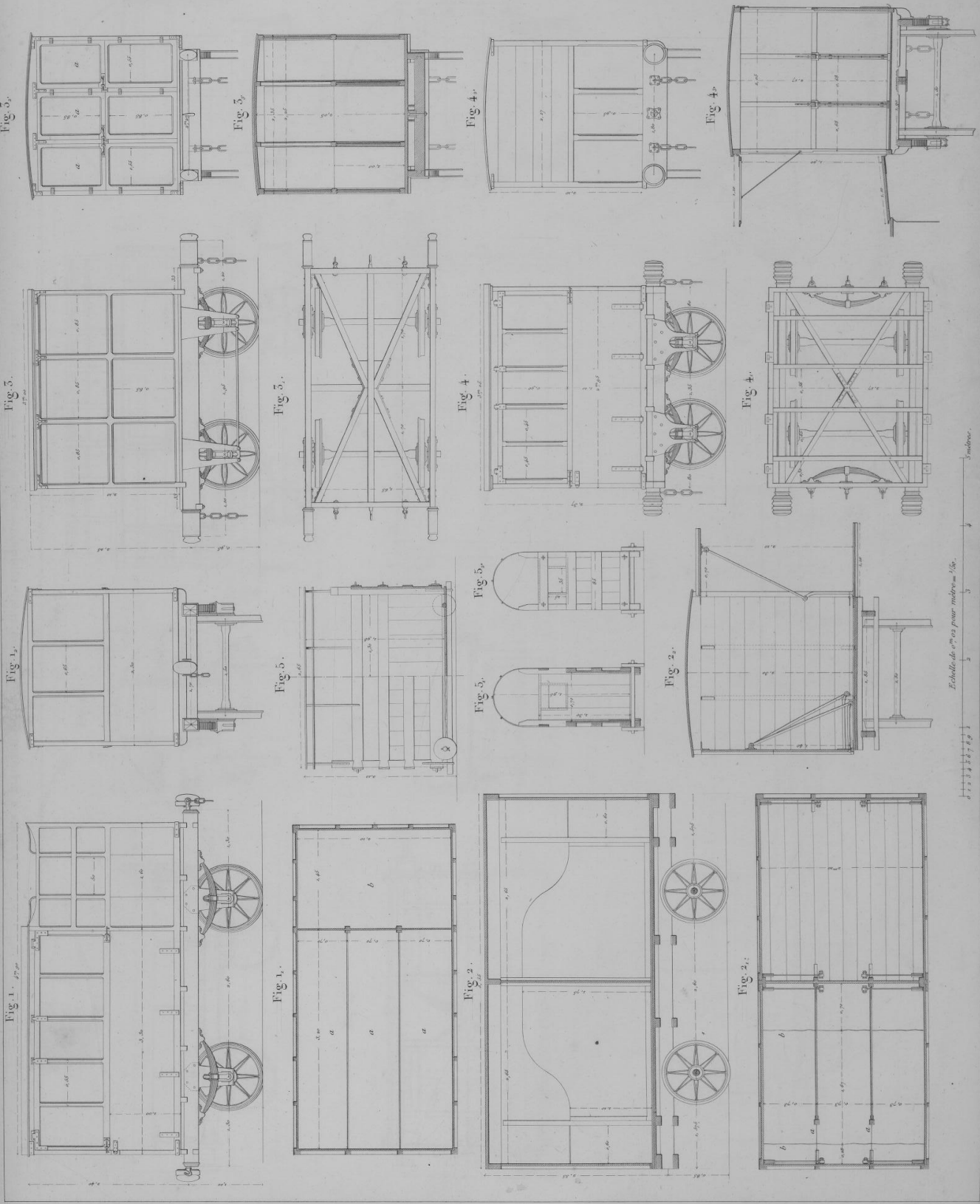

Vagons à marchandises et Vagon frein employés sur le plan incliné de Liège .

G. II.

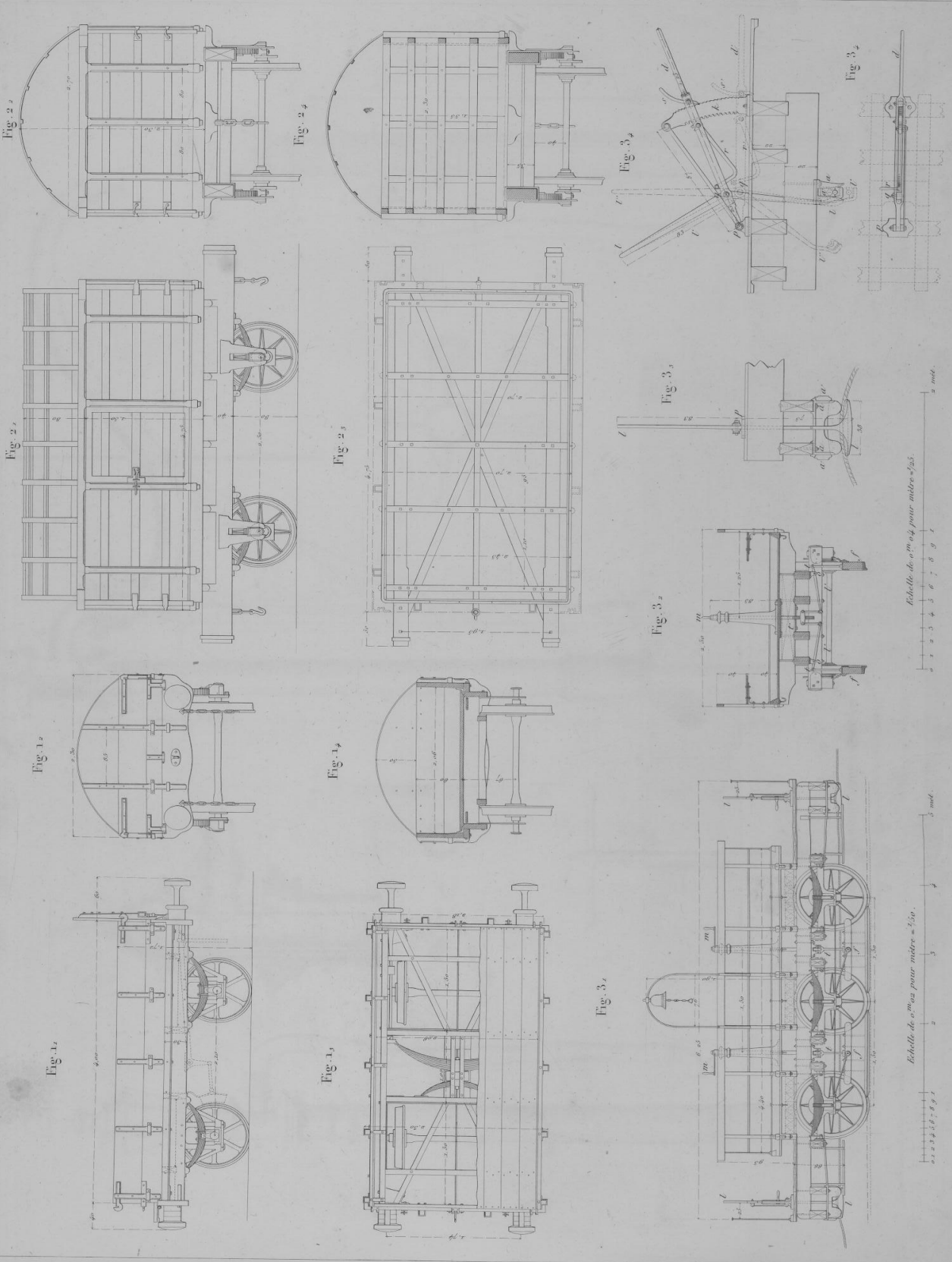

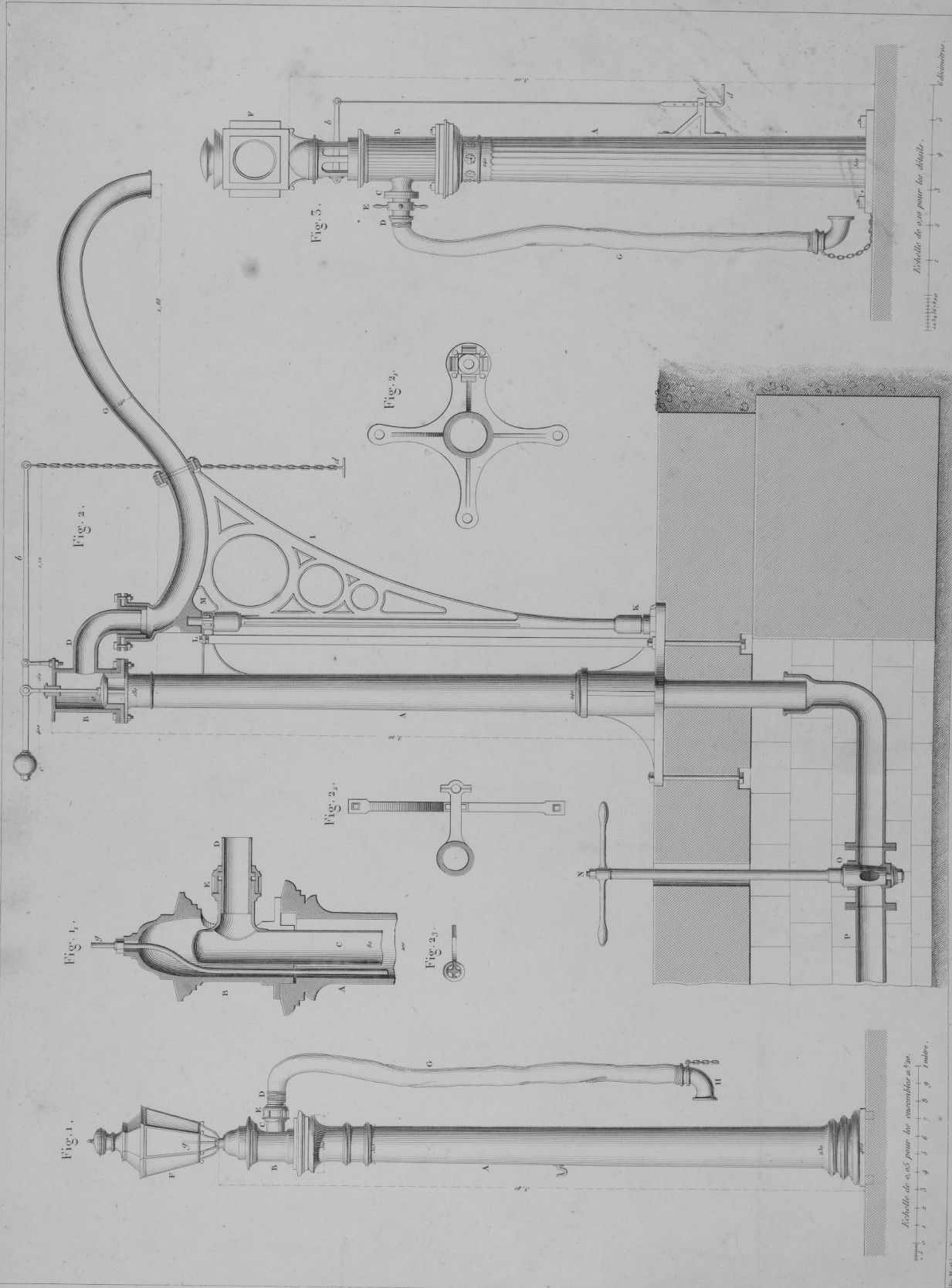

Crue hydraulique de Birmingham.

Fig. 1.

Fig. 2.

Fig. 3.

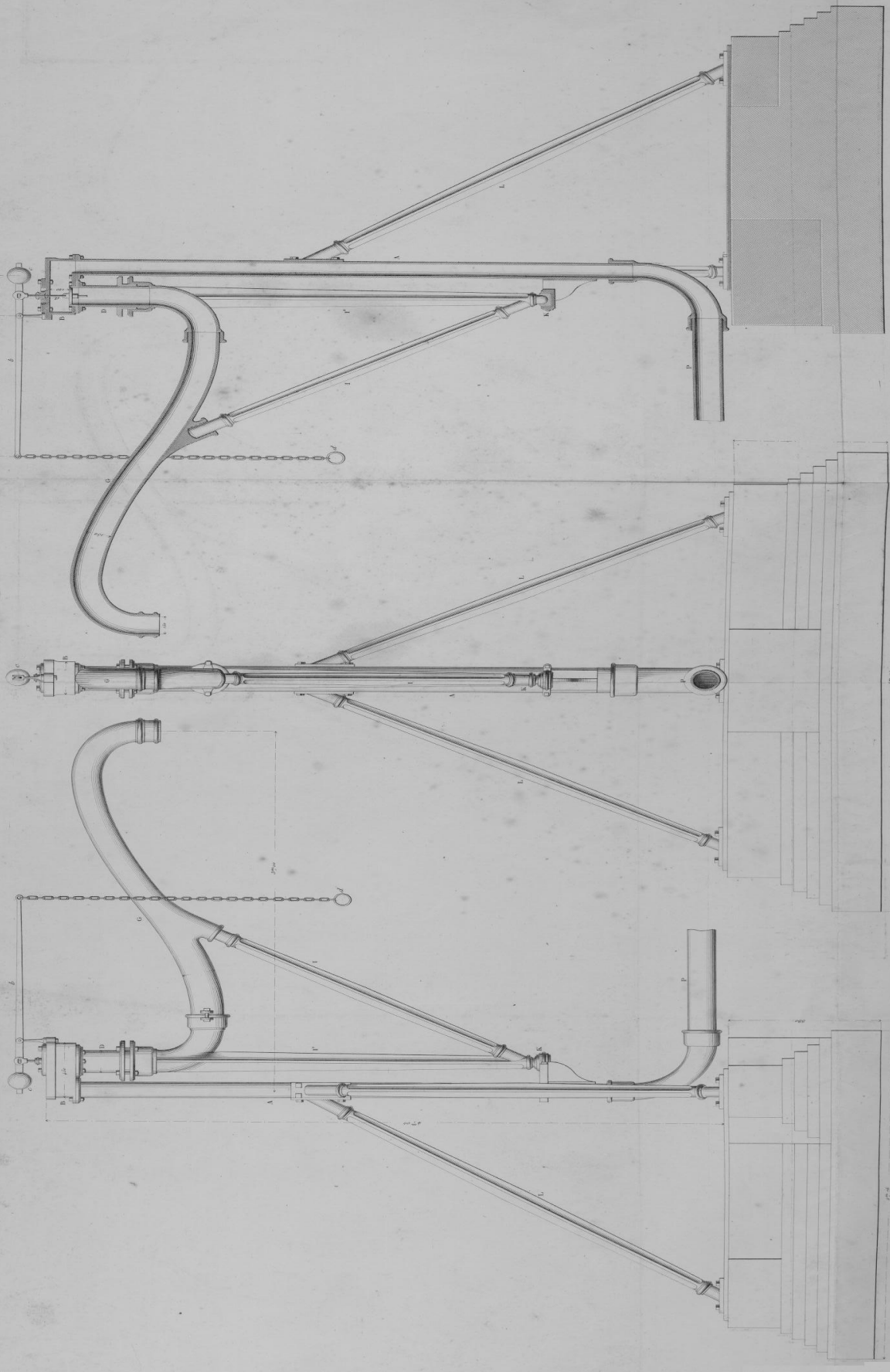

Echelle de 0^m10 pour nombre = 1/20.

millim.

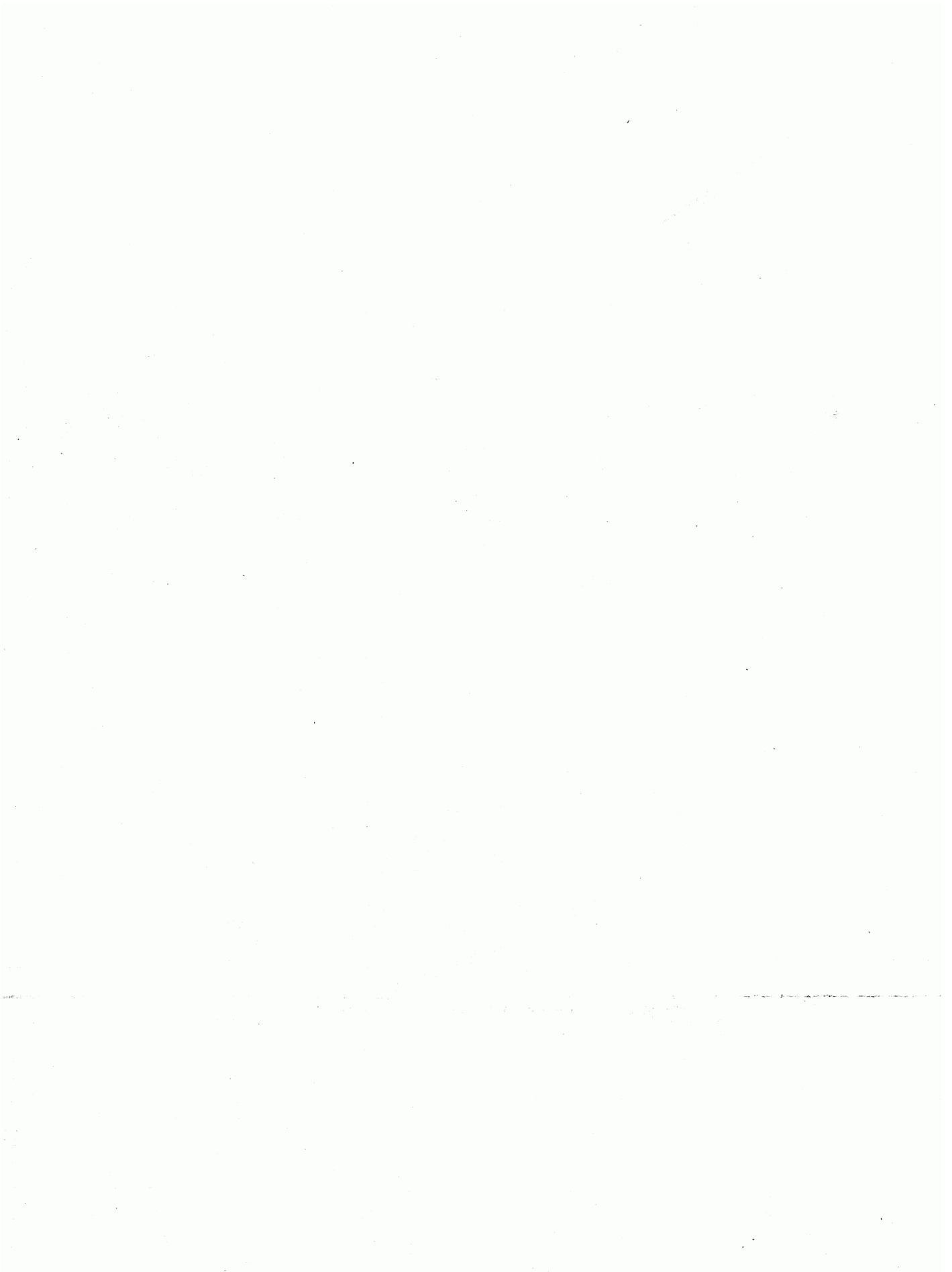

Truc hydraulique du chemin d'Orléans.

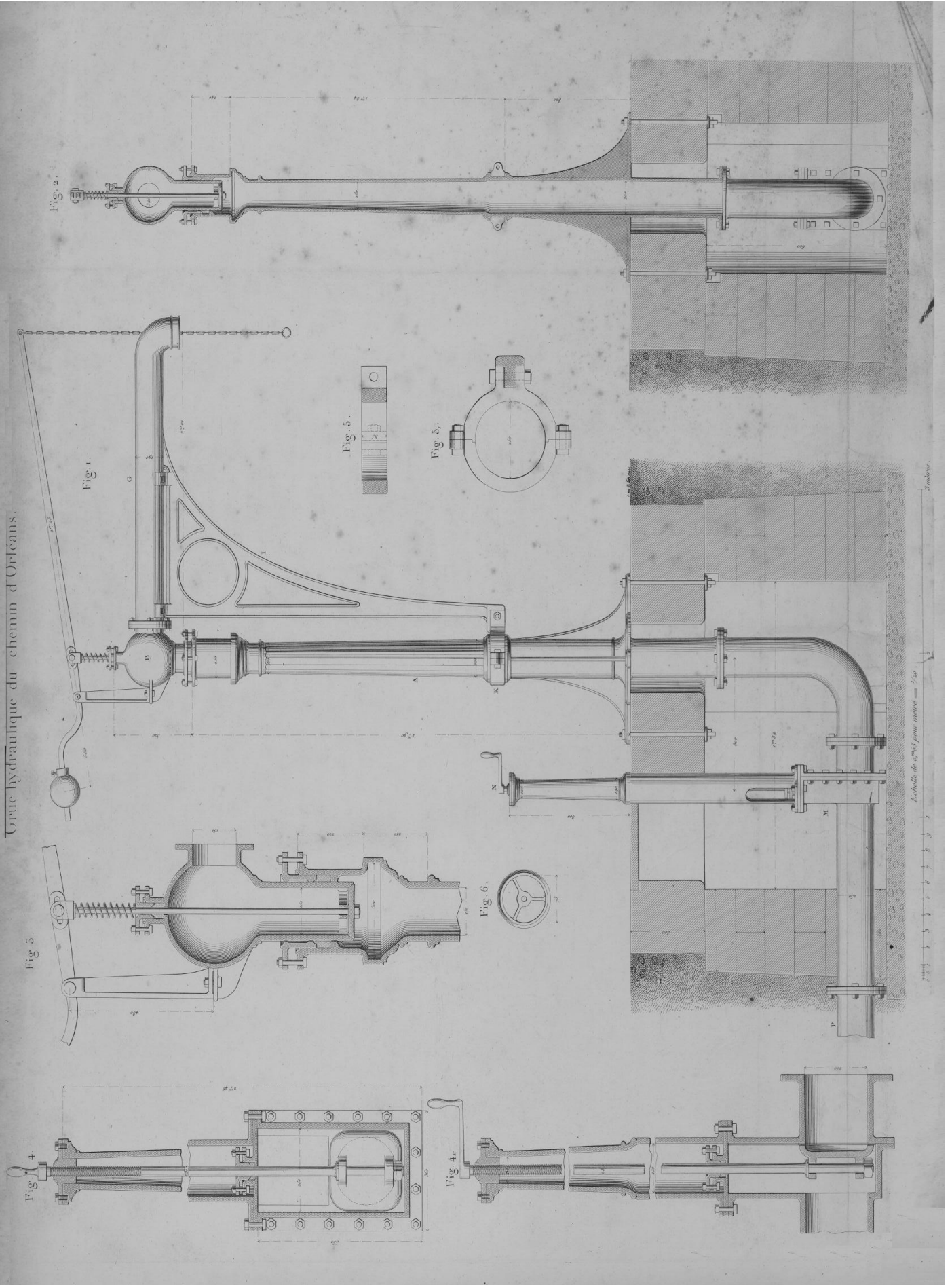

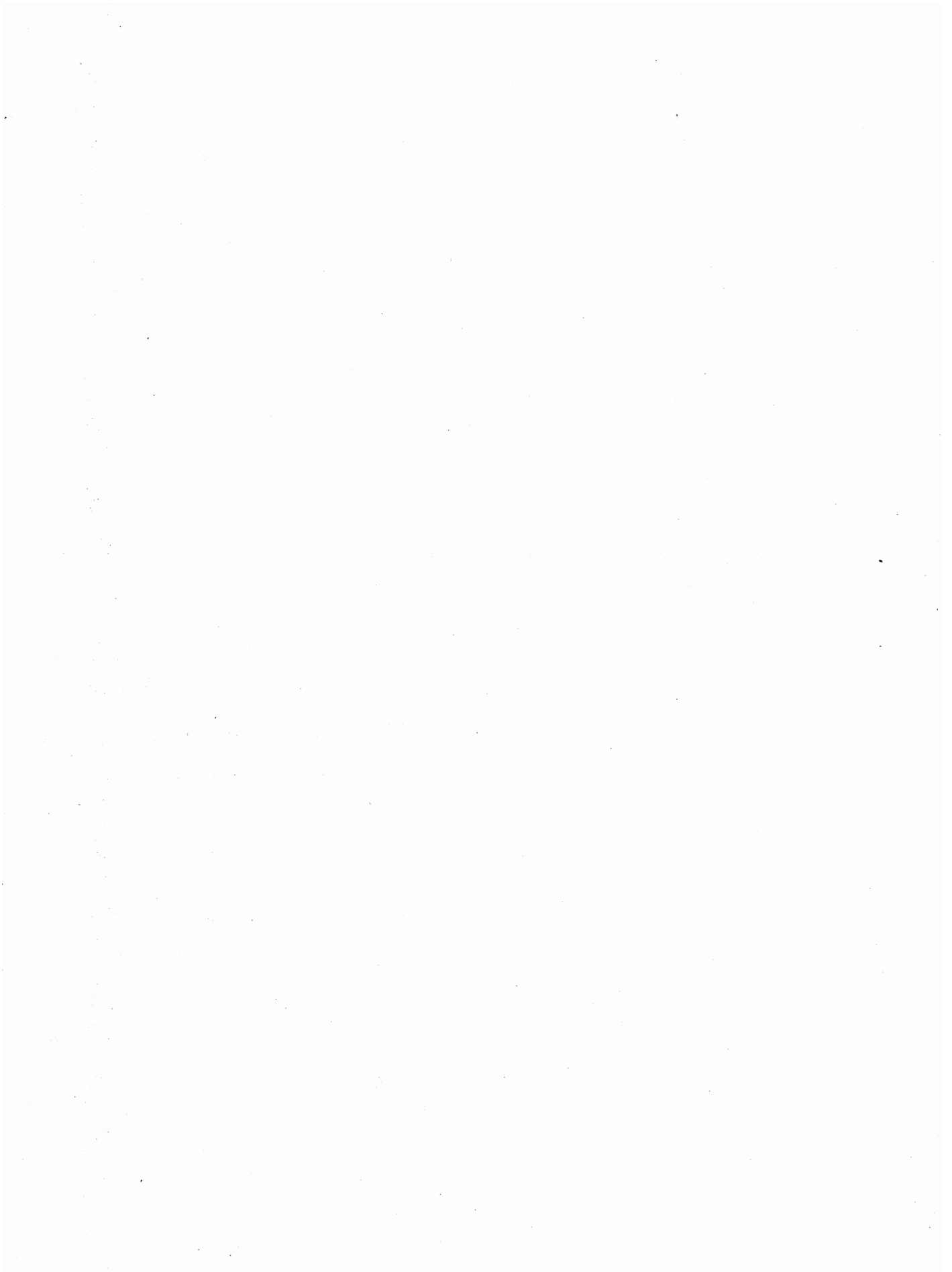

Crue hydraulique du chemin de Bâle à Strasbourg.

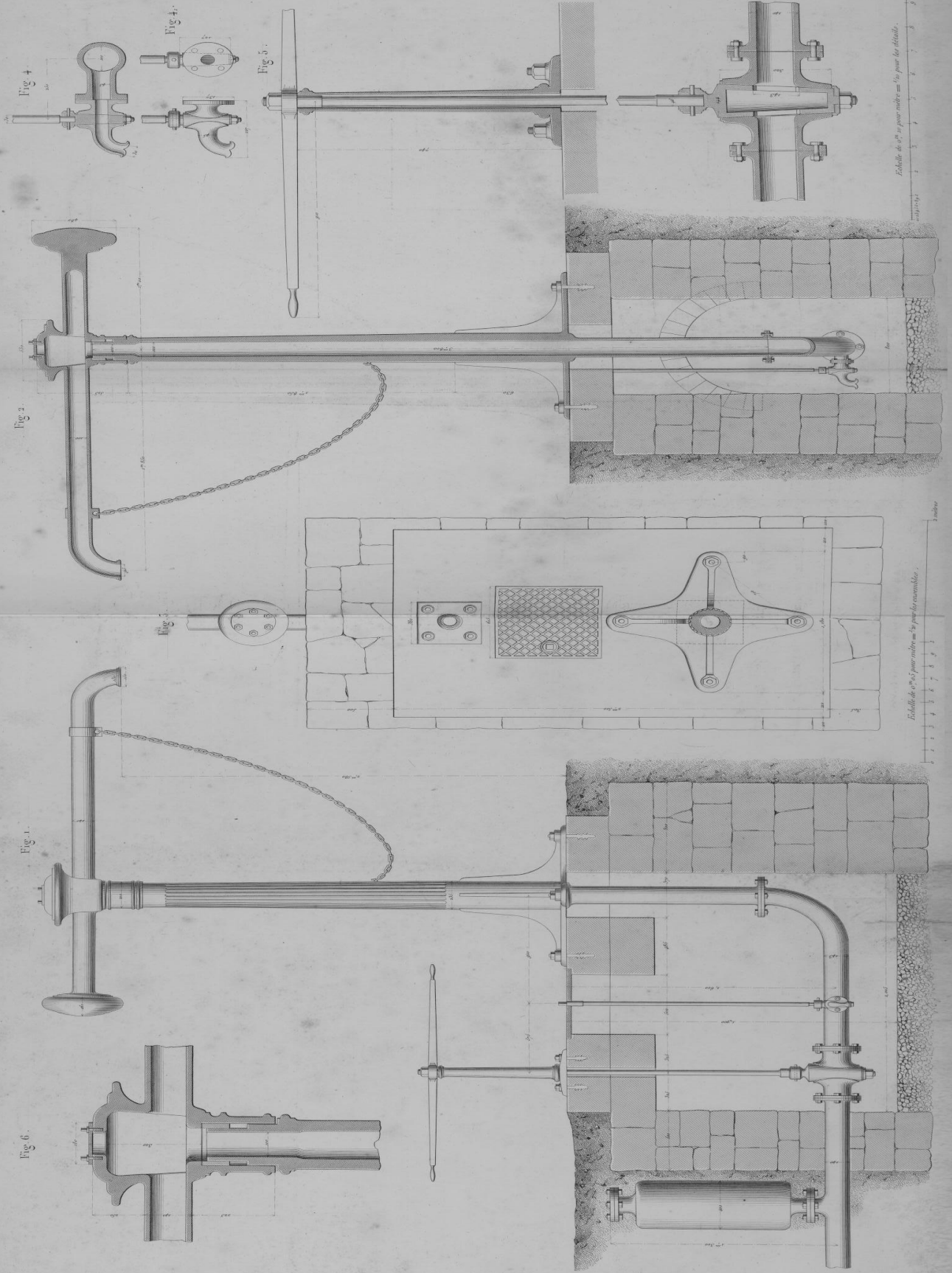



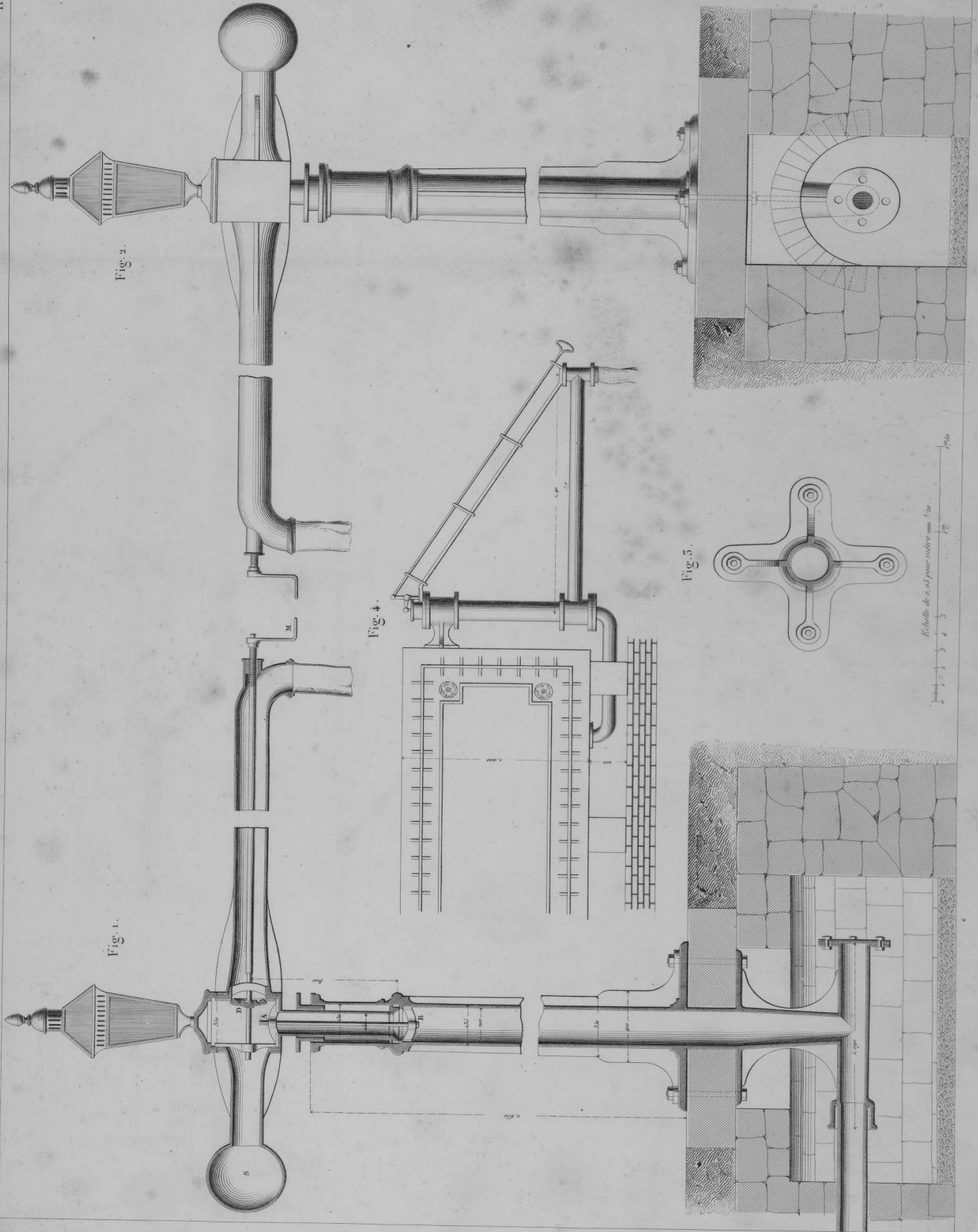

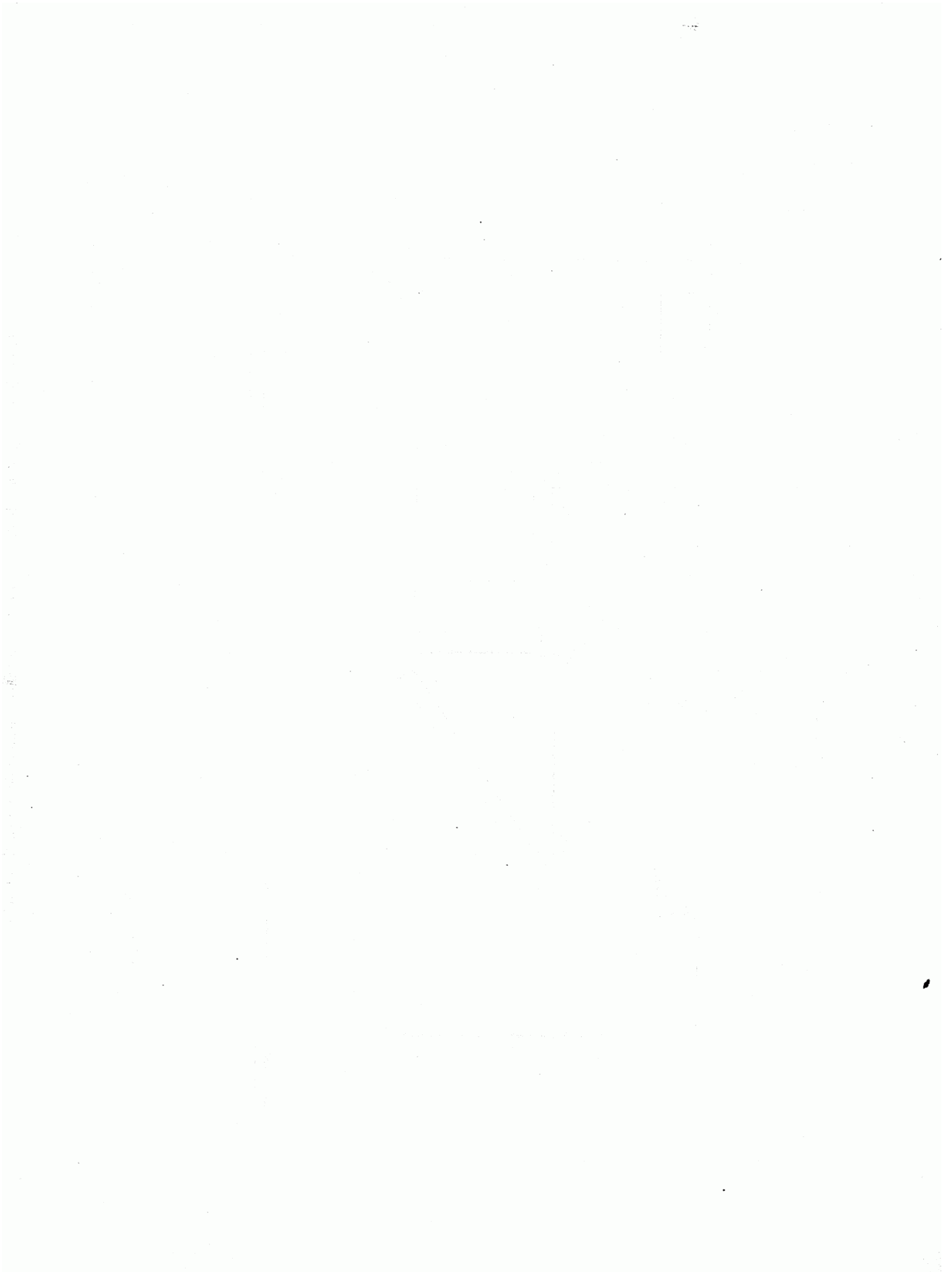

Fig. 1.

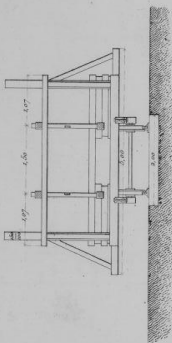

Fig. 1.

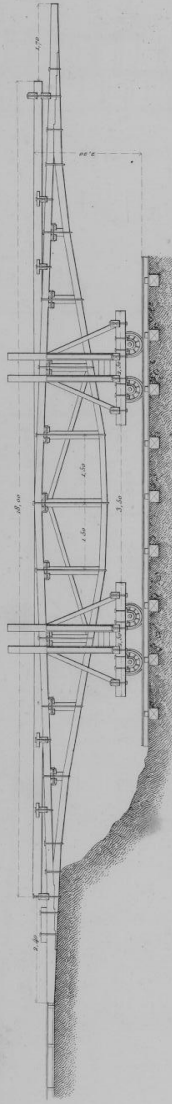

Fig. 2.

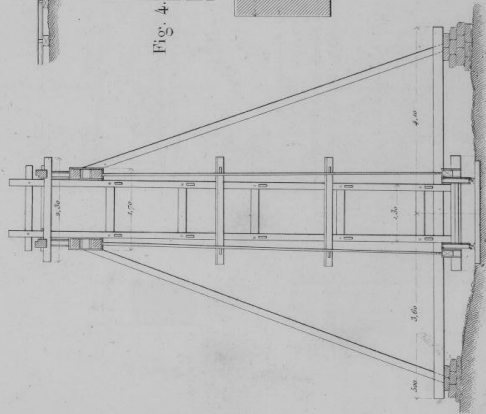

Fig. 3.

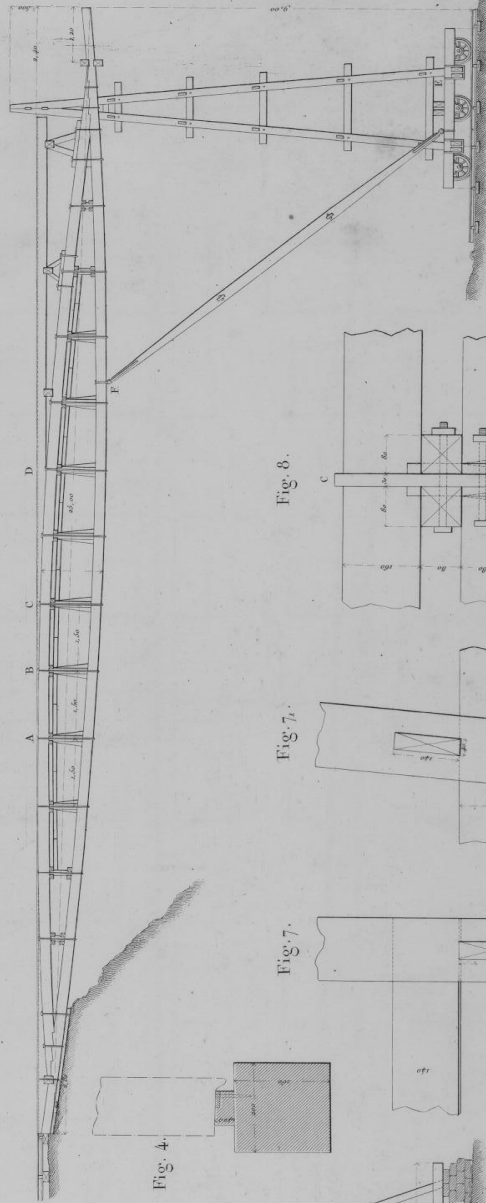

Fig. 4.

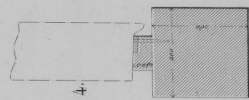

Fig. 7.

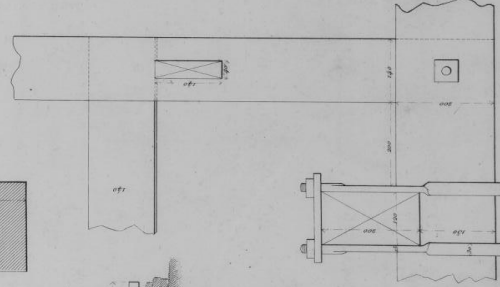

Fig. 7.

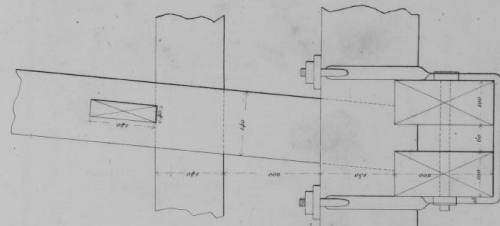

Fig. 8.

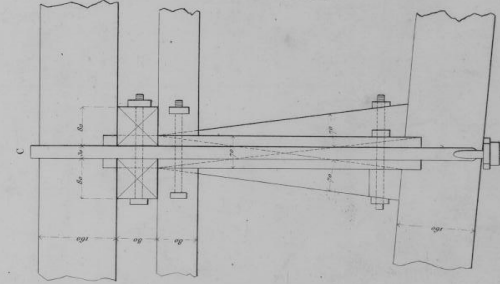

Fig. 5.

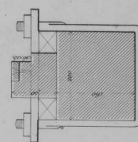

Fig. 6.



Fig. 9.

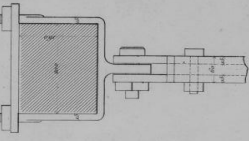
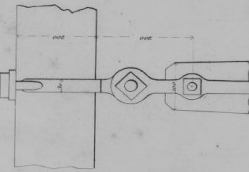

Fig. 9.



Echelle de 1/20 pour les détails.

Echelle de 1/50 pour le tout.

M. Mathis, Dessinateur.

M. Mathis, Dessinateur.

L. Mathis, Dessinateur pour M. Mathis, s.

Changement et croisement de voies provisoires.

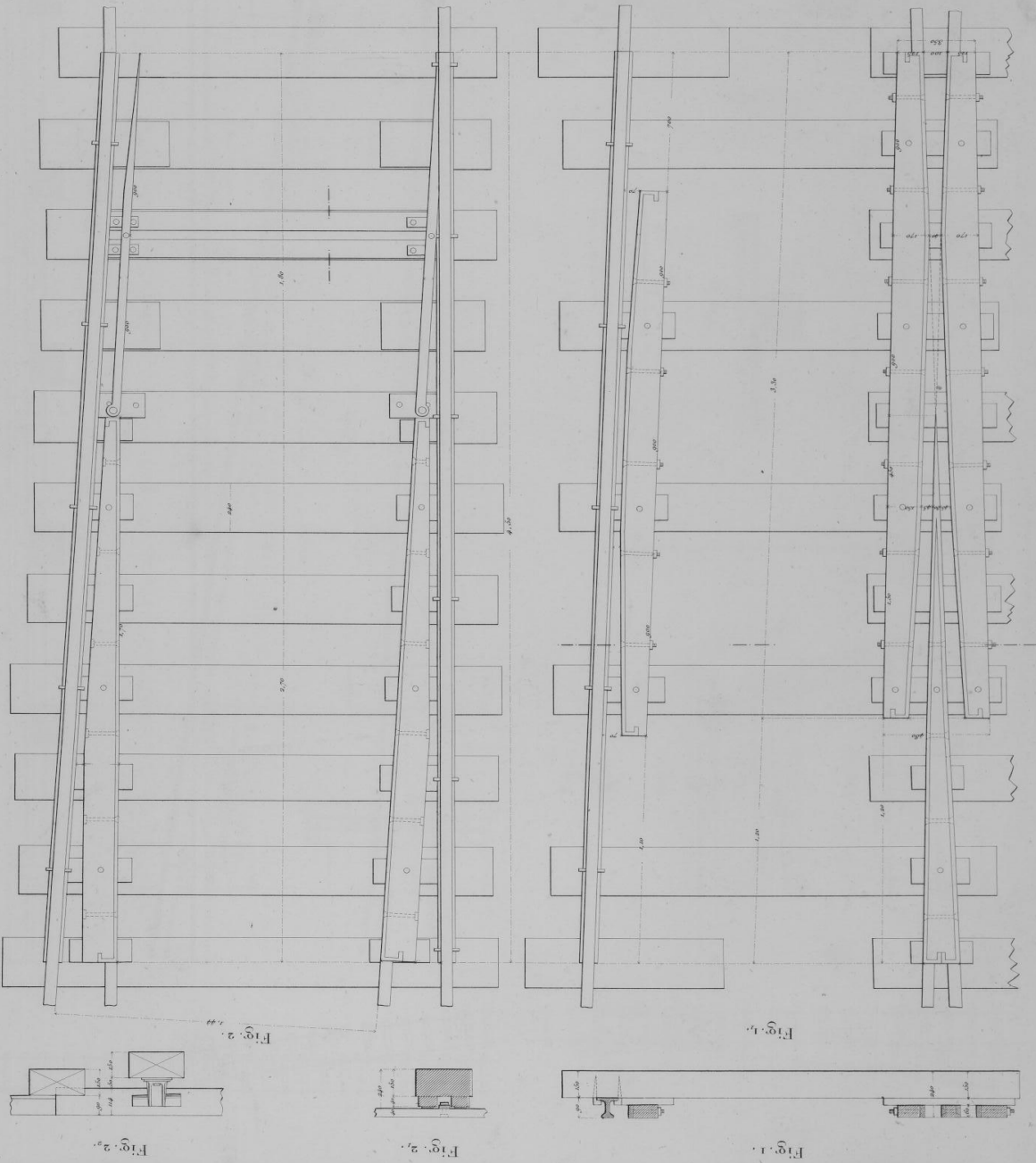

Echelle de 0,05 pour metre = 1/20.
Echelle de 0,05 pour metre.
2 metres.

Fig. 3.

Changement de voies pour terrassements.

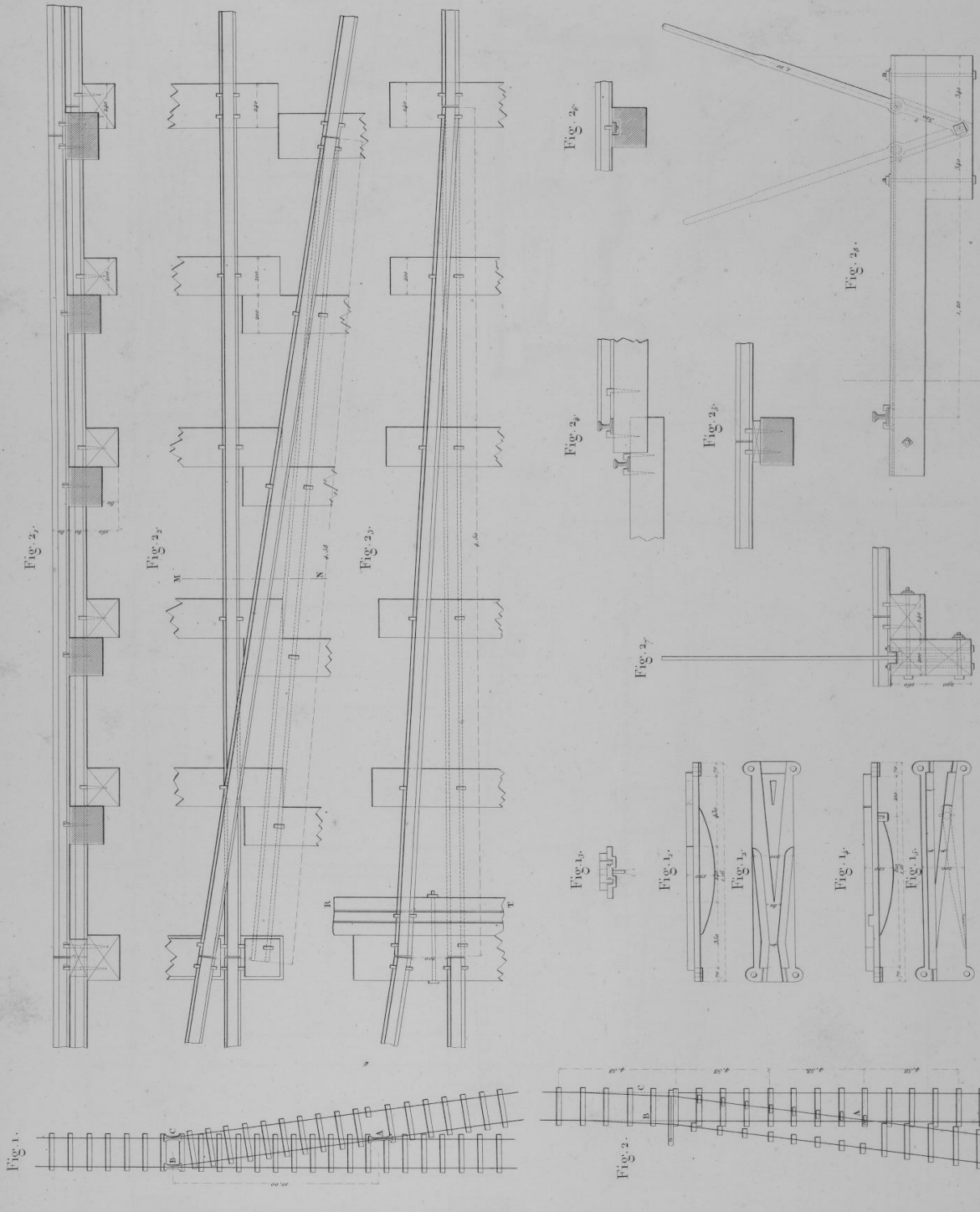

Echelle de bois pour metre = 2m.

Echelle de bois pour metre = 2m.

Echelle de bois pour metre = 2m.

Changement de voies pour terrassement et poulie de plan automoteur.

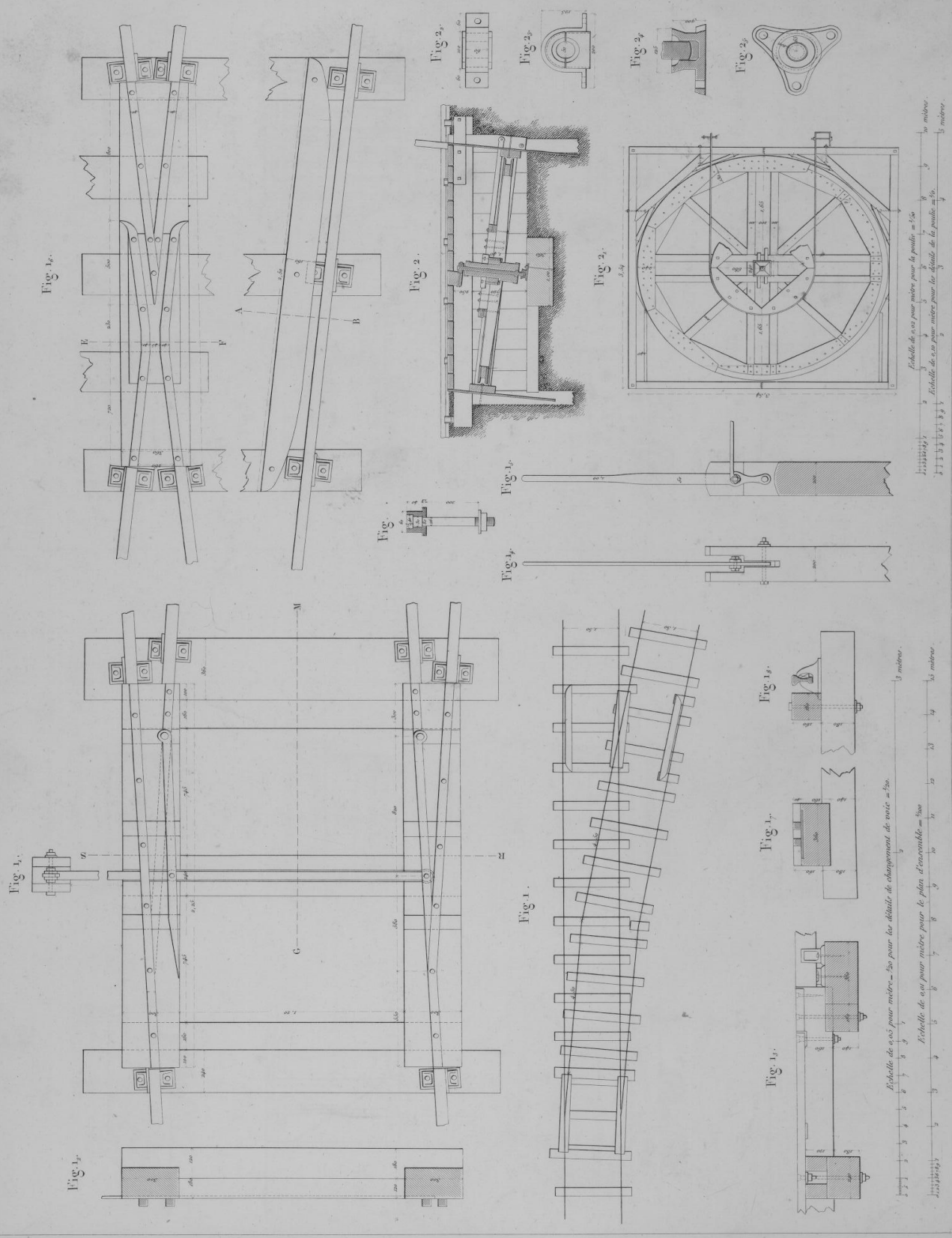

Fig. 1.

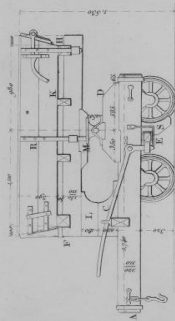

Fig. 1.

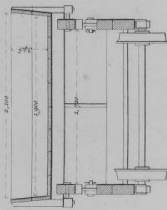

Fig. 1.

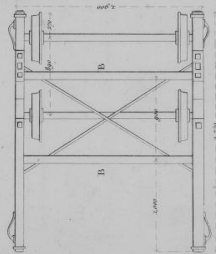

Fig. 1.

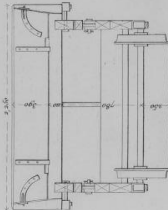

Fig. 2.

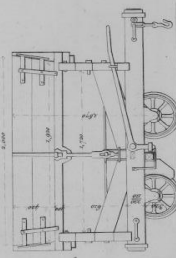

Fig. 2.

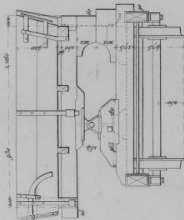

Fig. 2.

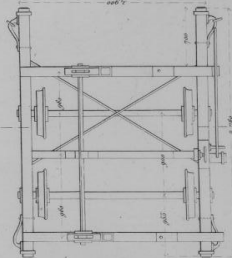
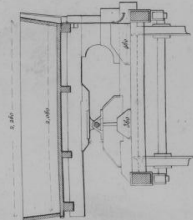

Fig. 2.



Echelle de 0^m100 pour metre = 1/10.
1 2 3 4 5 6 7 8 9 10
1 metre.

Fig. 5.

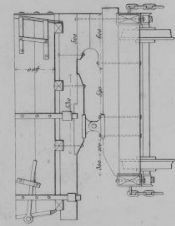

Fig. 5.

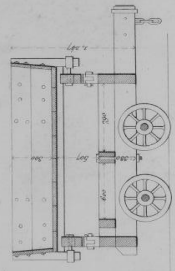

Fig. 5.

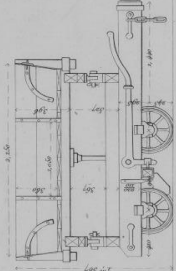

Fig. 5.

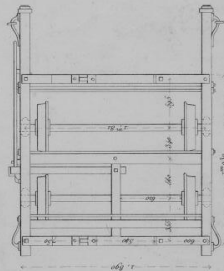

Fig. 4.

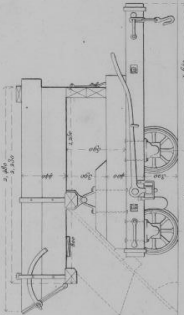

Fig. 4.

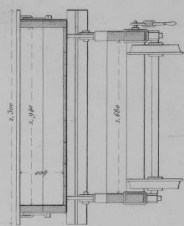

Fig. 4.

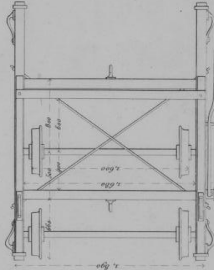
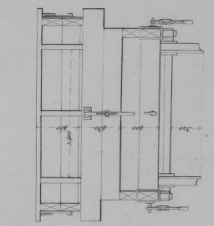
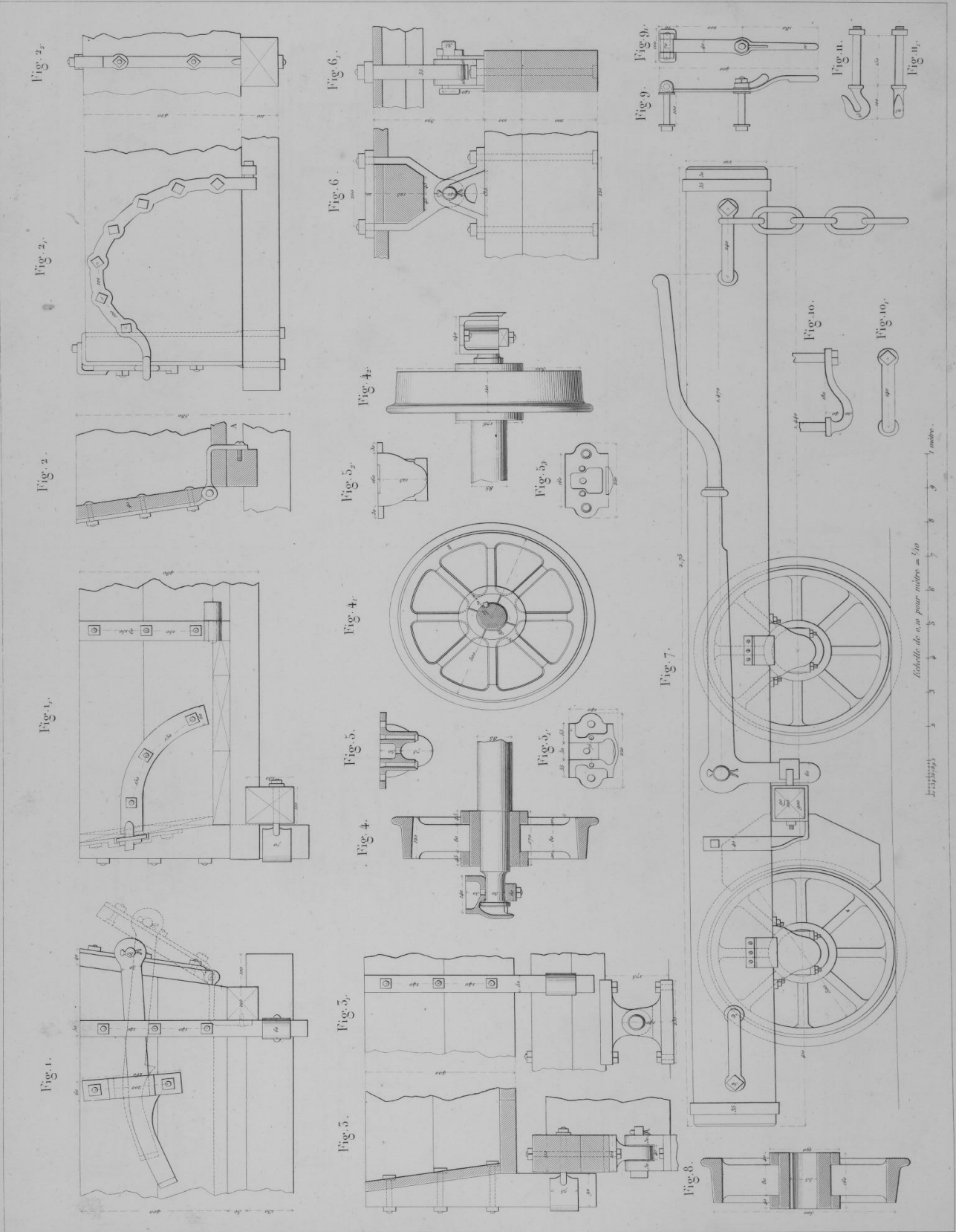

Fig. 4.



Echelle de 0^m100 pour metre = 1/10.
1 2 3 4 5 6 7 8 9 10
1 metre.



0

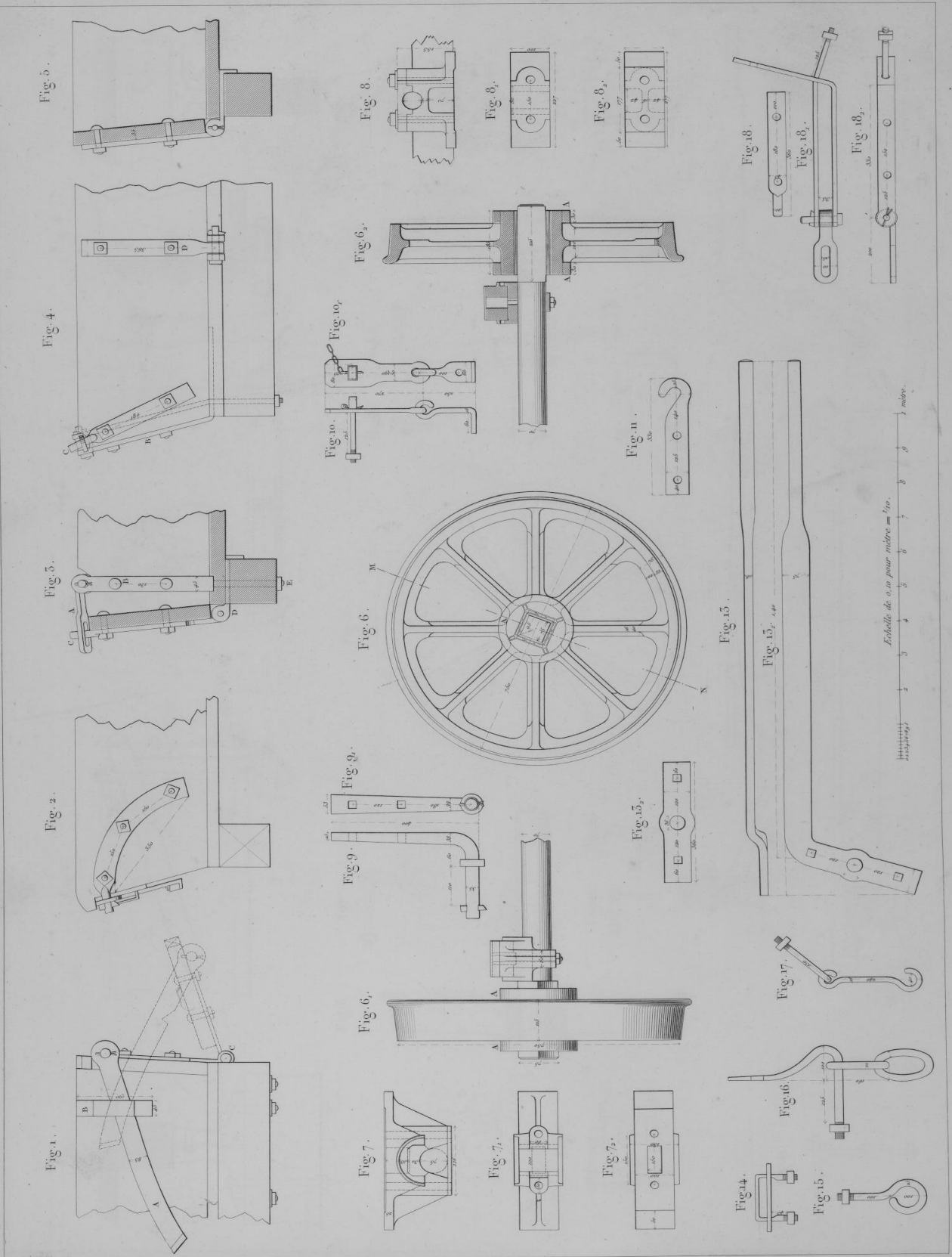

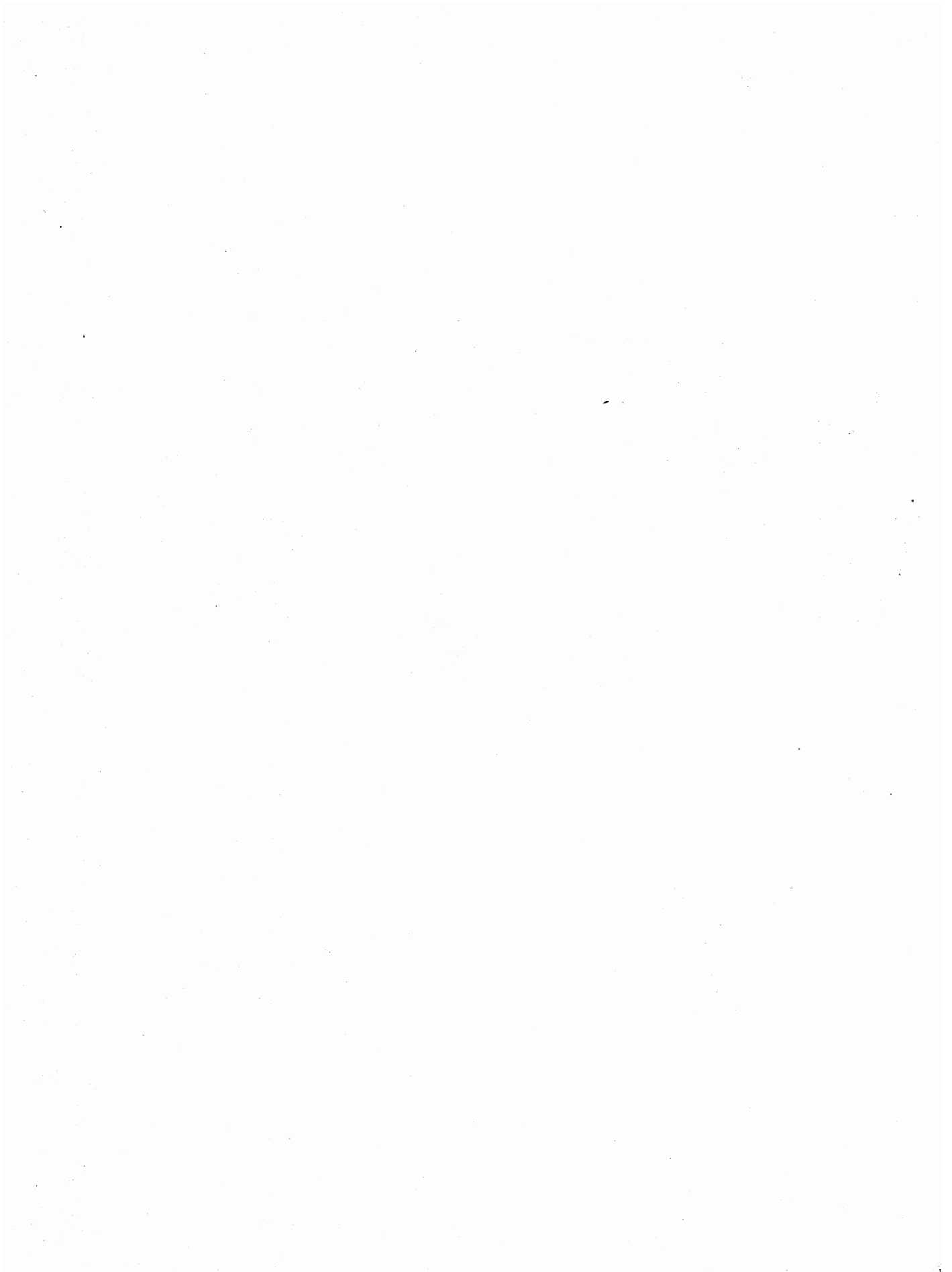

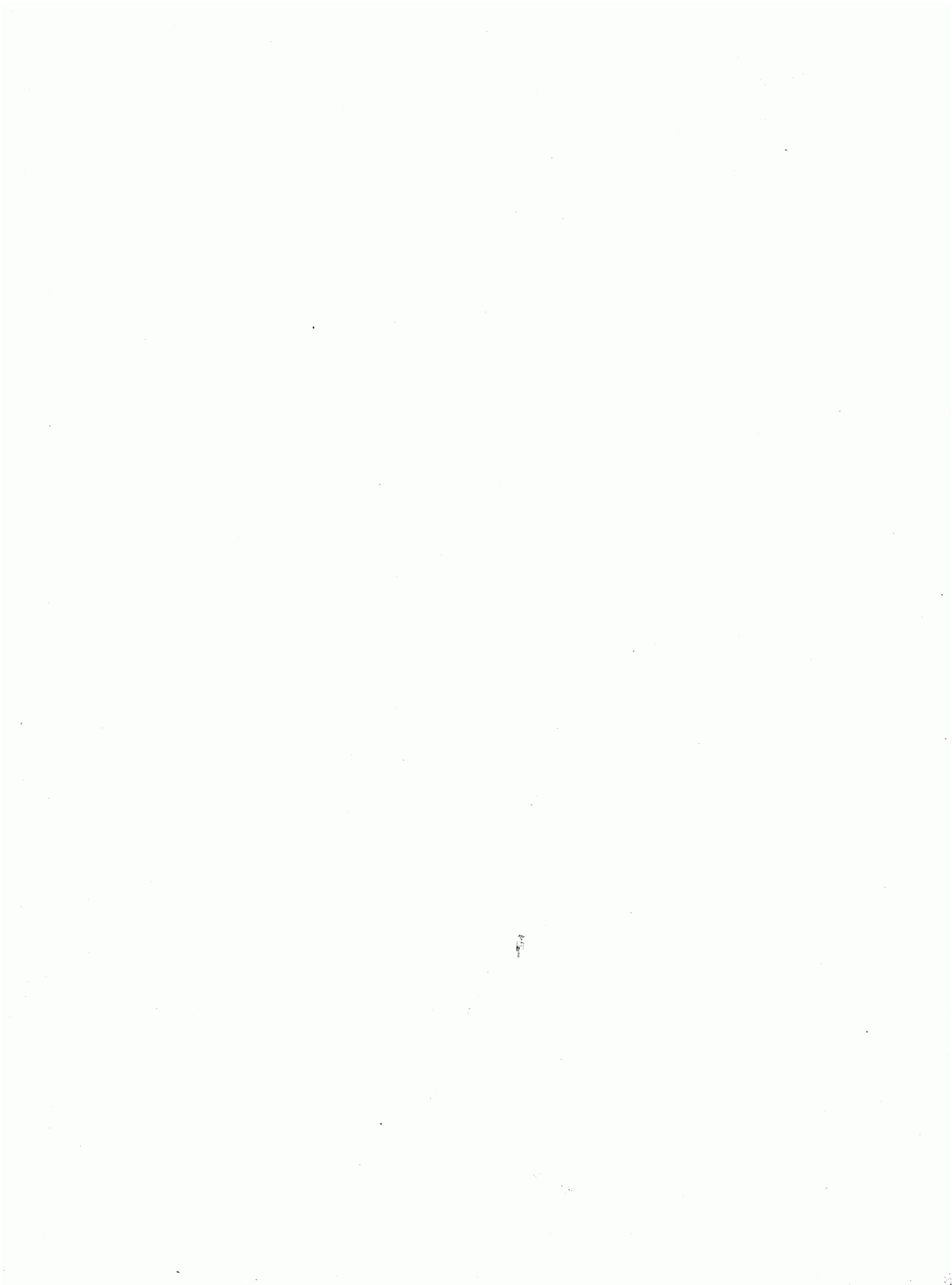

Détails des wagons de terrassement des chemins de fer du Nord et de Rouen.

J. II.

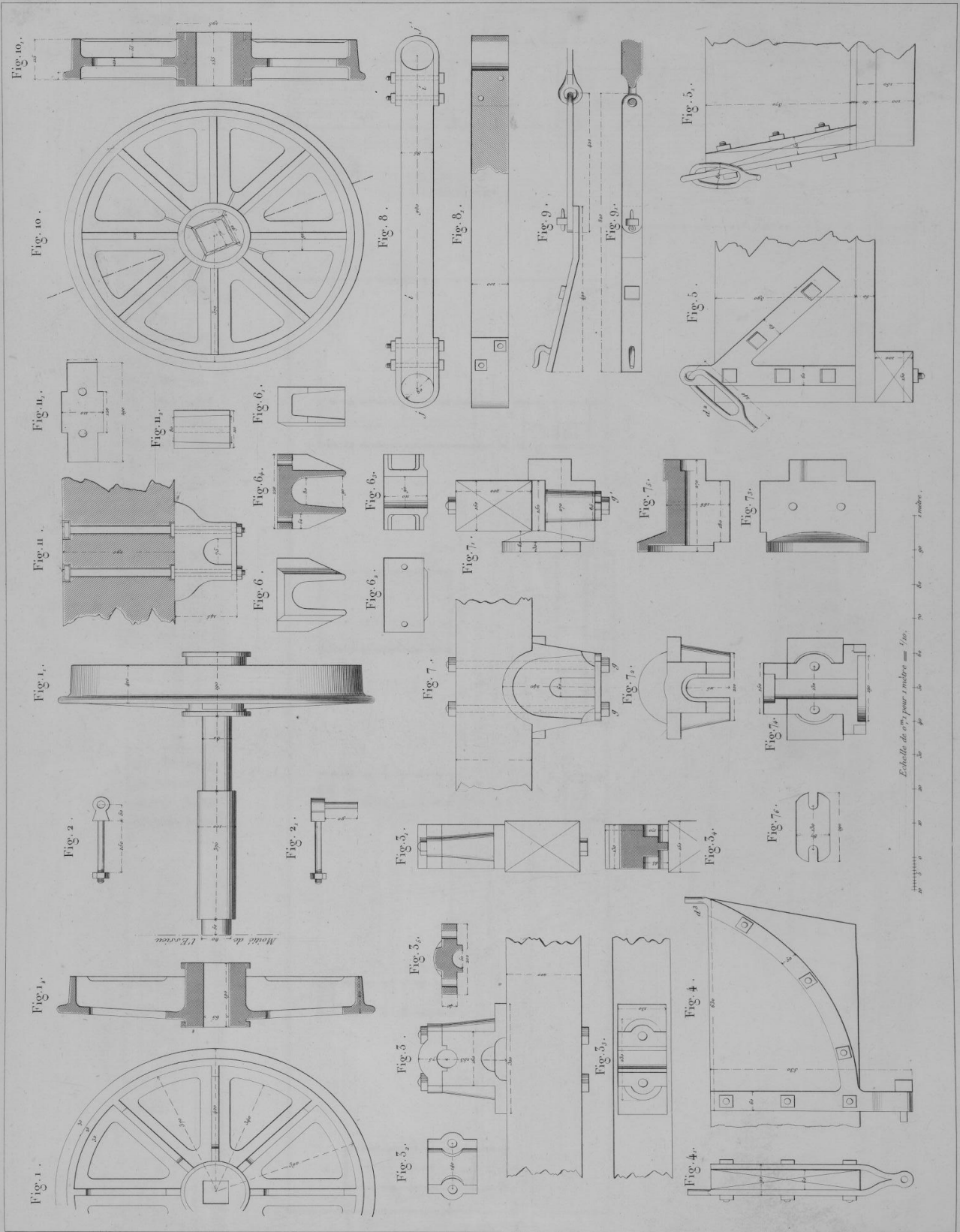

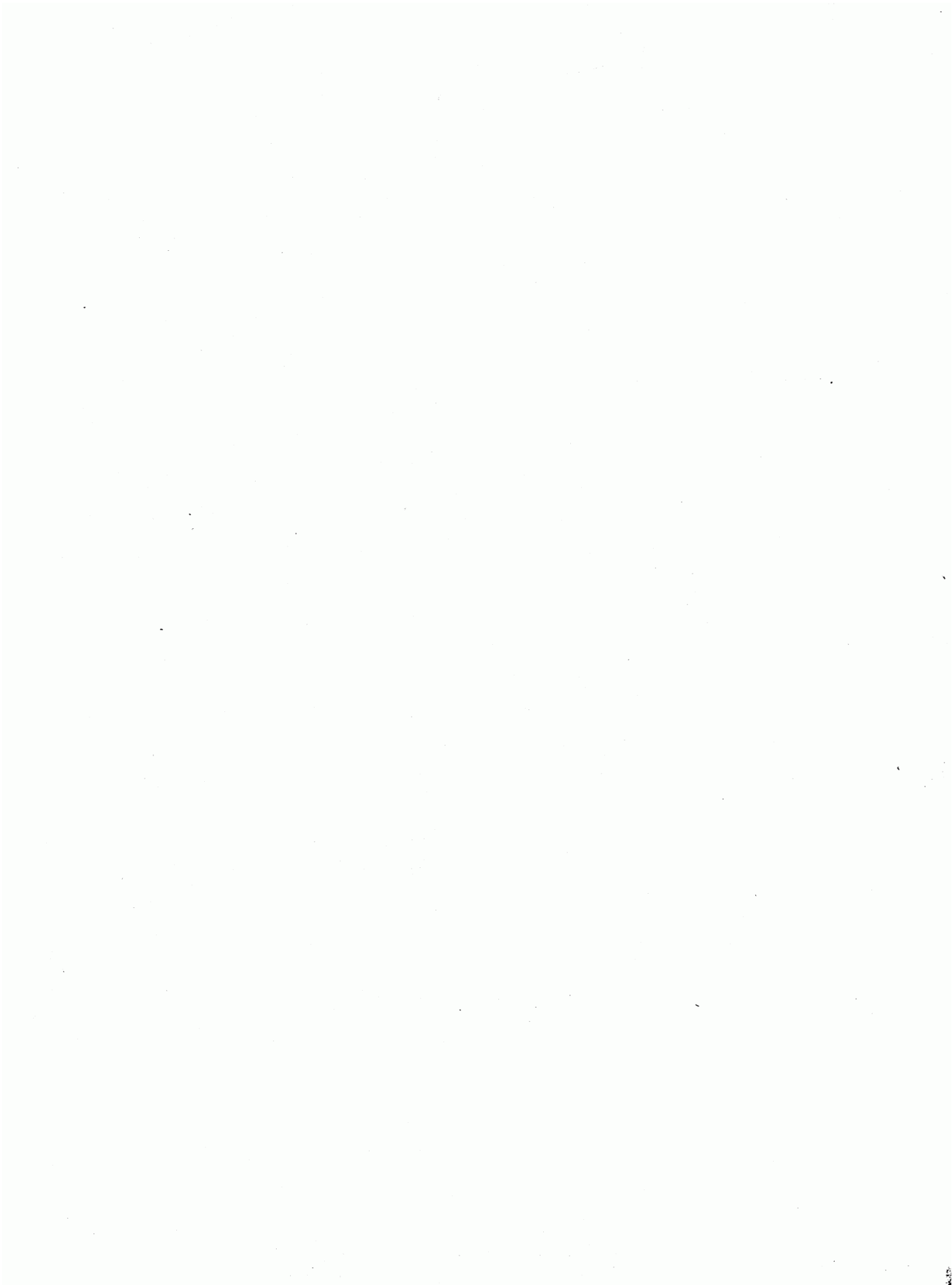

Fig. 1.

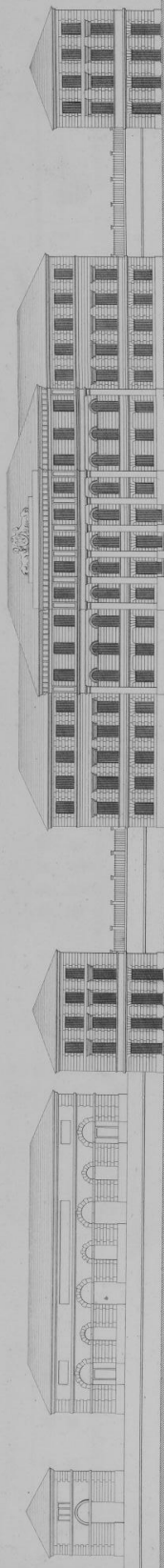

Fig. 2.

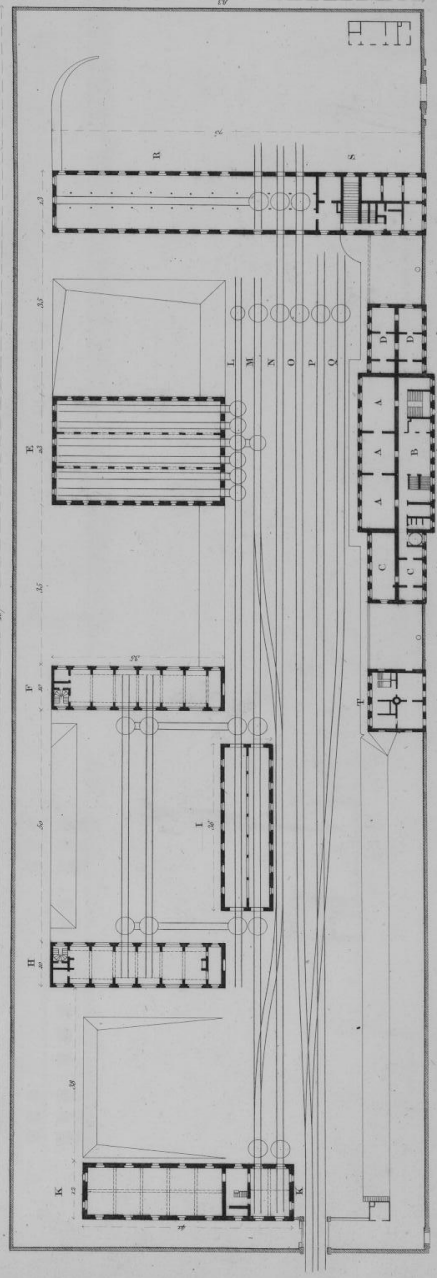

Fig. 4.

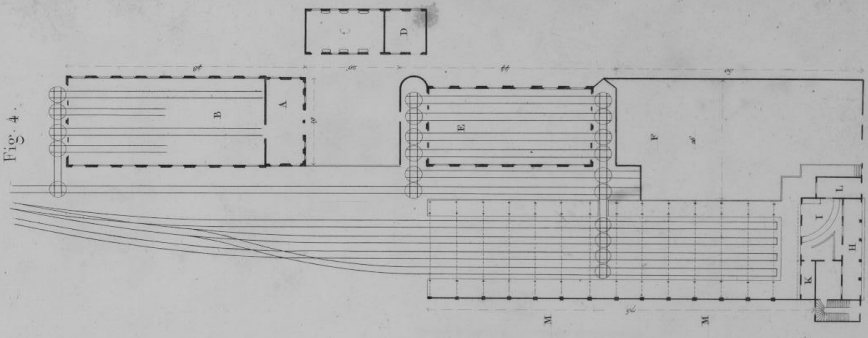

Fig. 5.



Fig. 6.

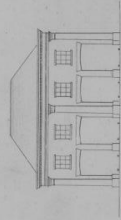
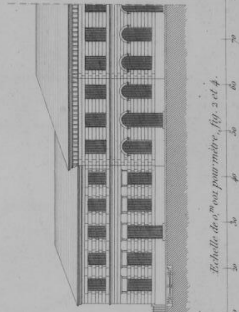

Fig. 3.



Échelle de 1/1000 pour mètres, fig. 1 et 2.
Échelle de 1/2000 pour mètres, fig. 3, 4 et 6.
10 mètres
100 mètres

L. Mathieu, Éditeur, quai Malakois, 15.

Fig. 9.



Fig. 10.

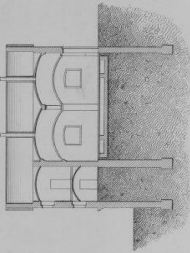

Fig. 4.

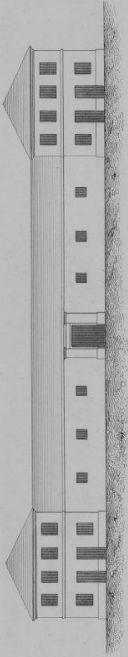

Fig. 6.

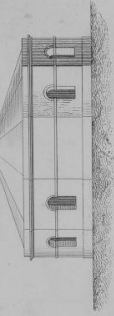

Fig. 8.

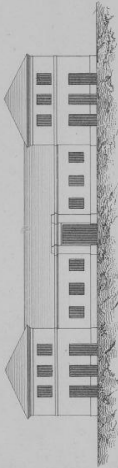

Fig. 5.

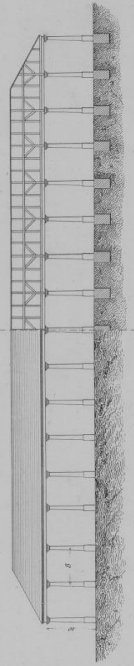

Fig. 7.

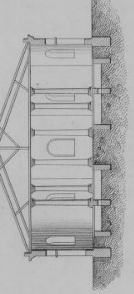

Fig. 2.

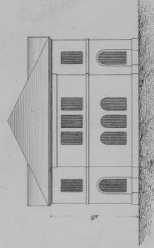

Fig. 5.

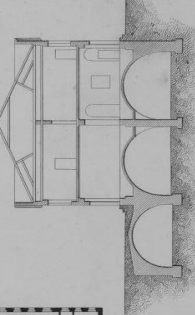
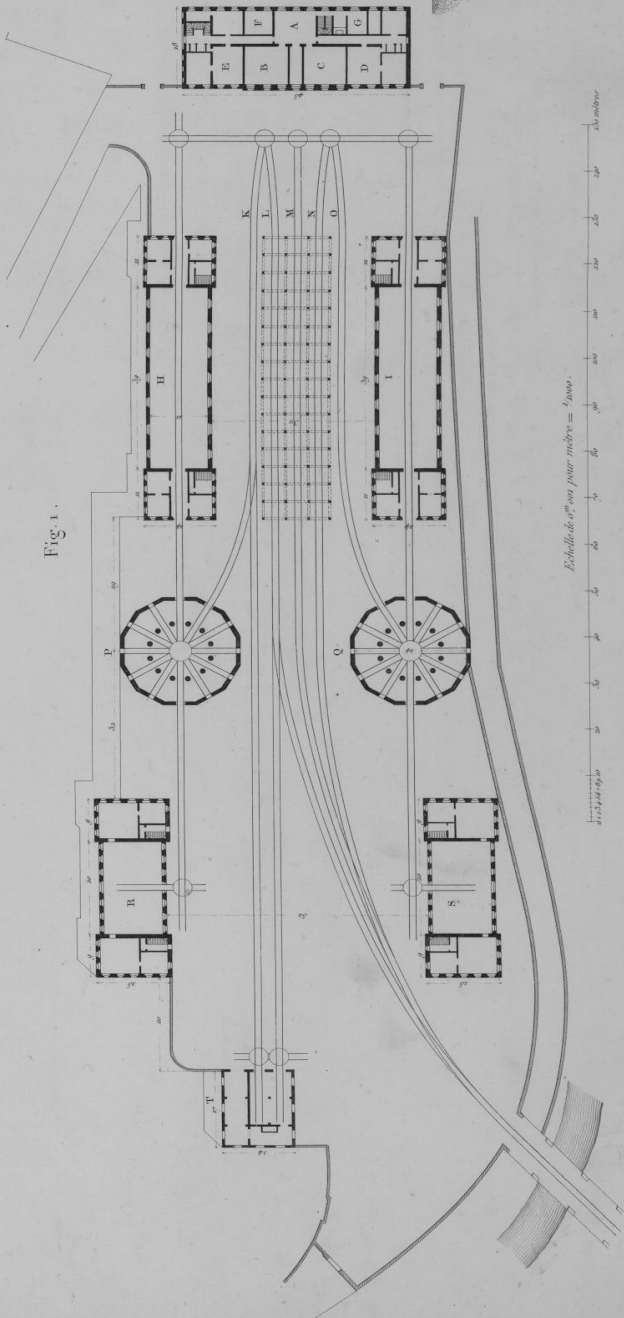

Fig. 1.



Echelle de 6^m sur pour metre = 1/1000.

Echelle de 6^m sur pour metre = 1/500.



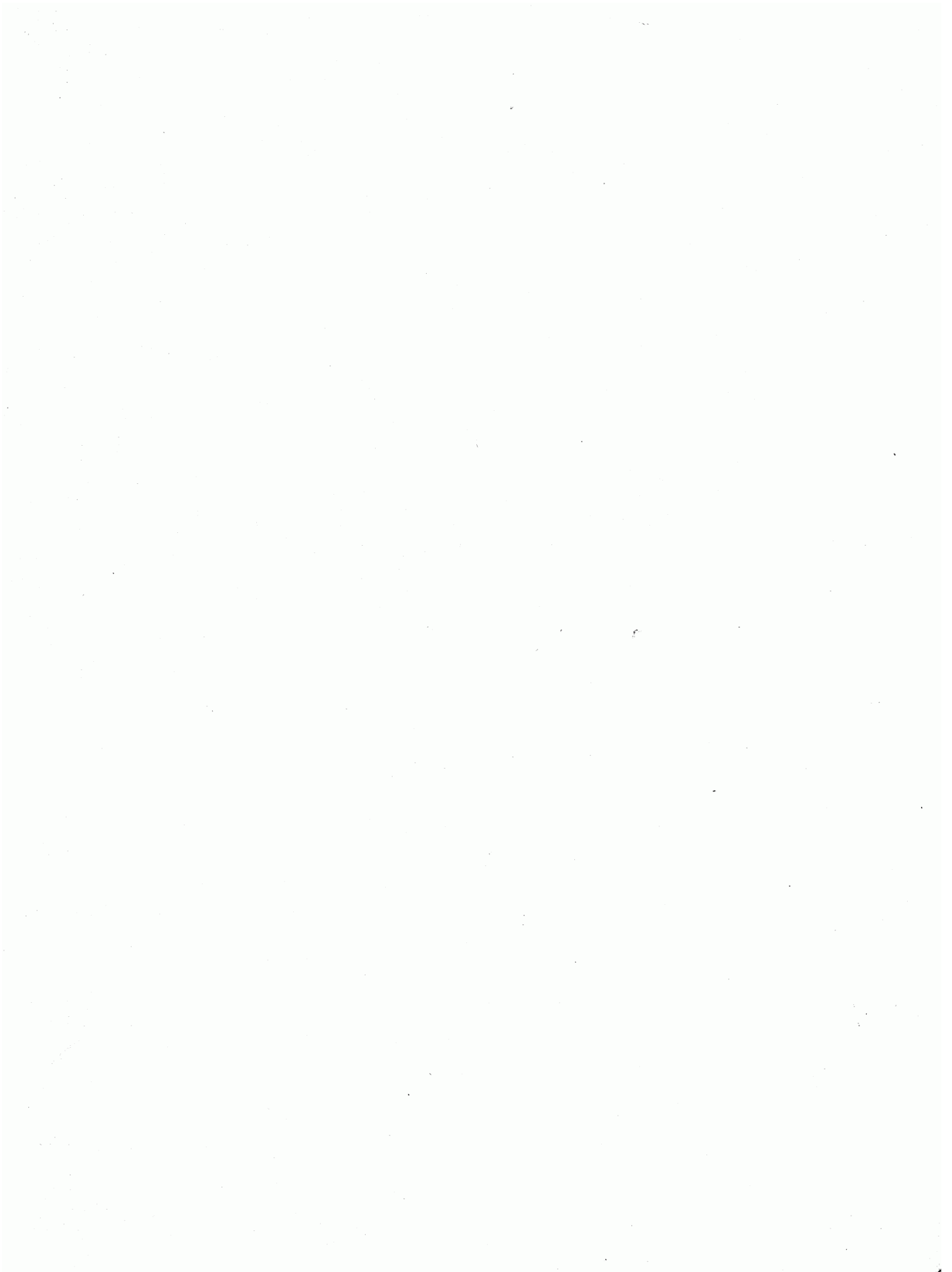

Gares du chemin de Versailles (R.D.) à Versailles et du chemin de St Germain au Pecq.

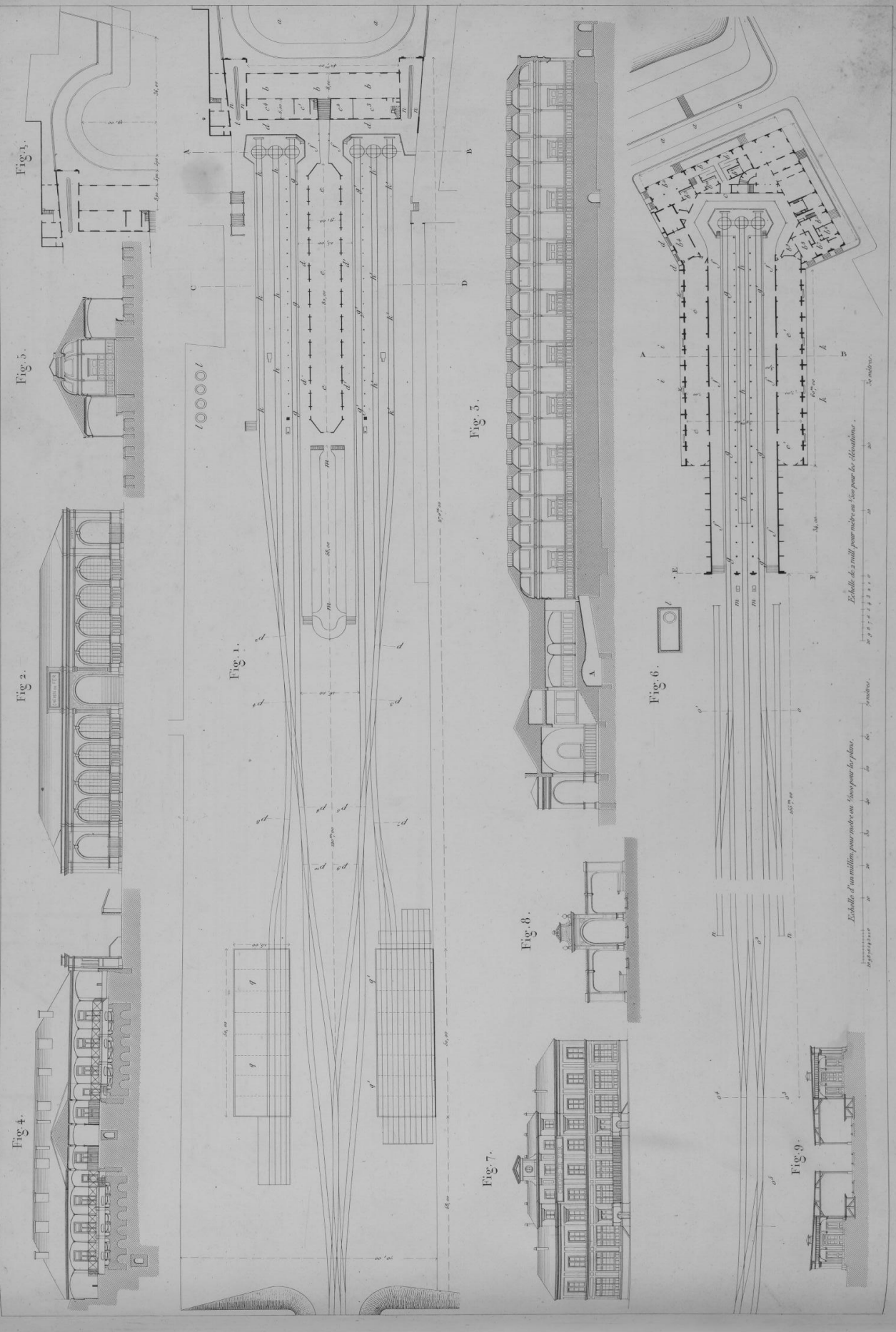



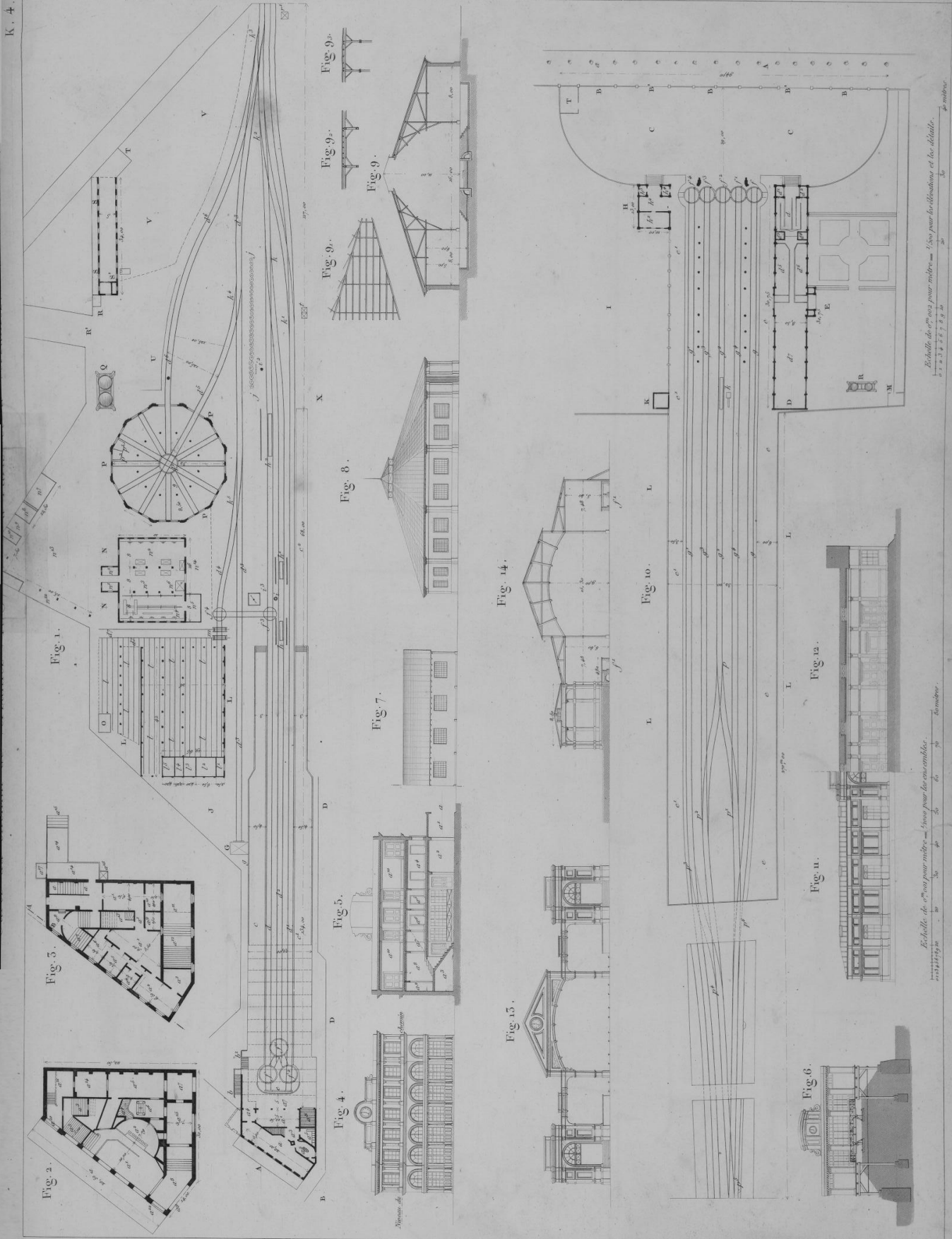

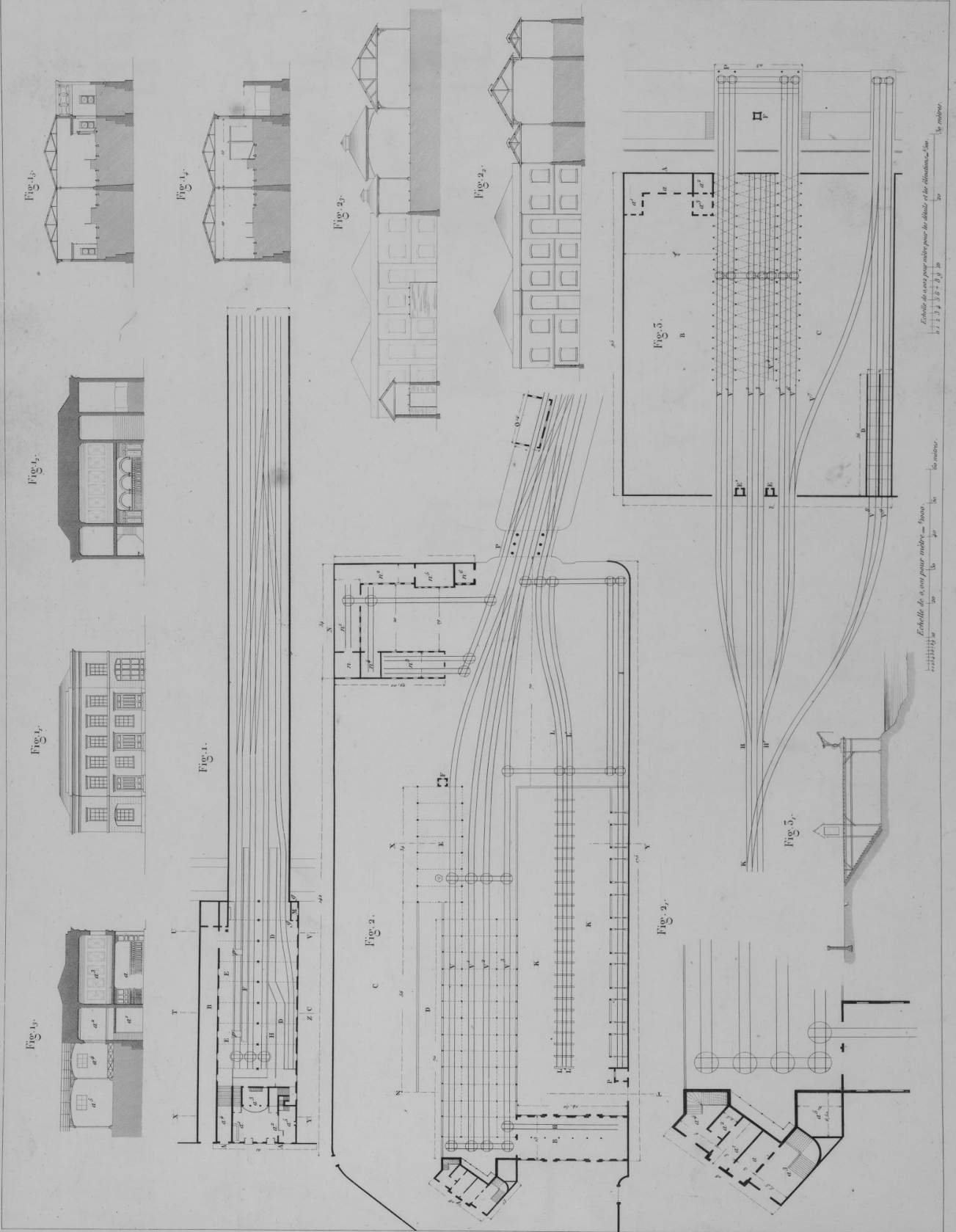

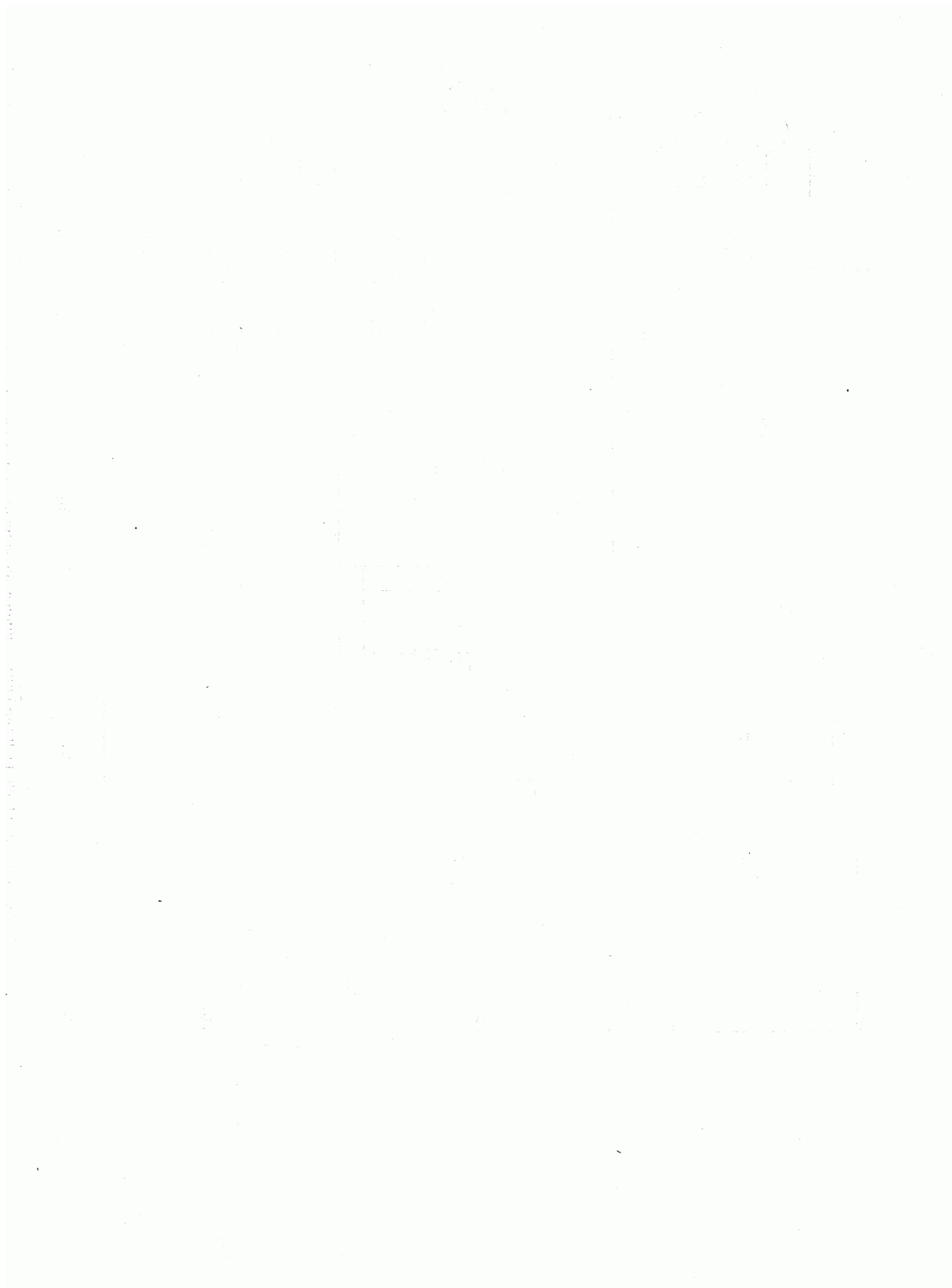

Gares de seconde et troisième classes du chemin de Strasbourg à Bâle.

K. 6.

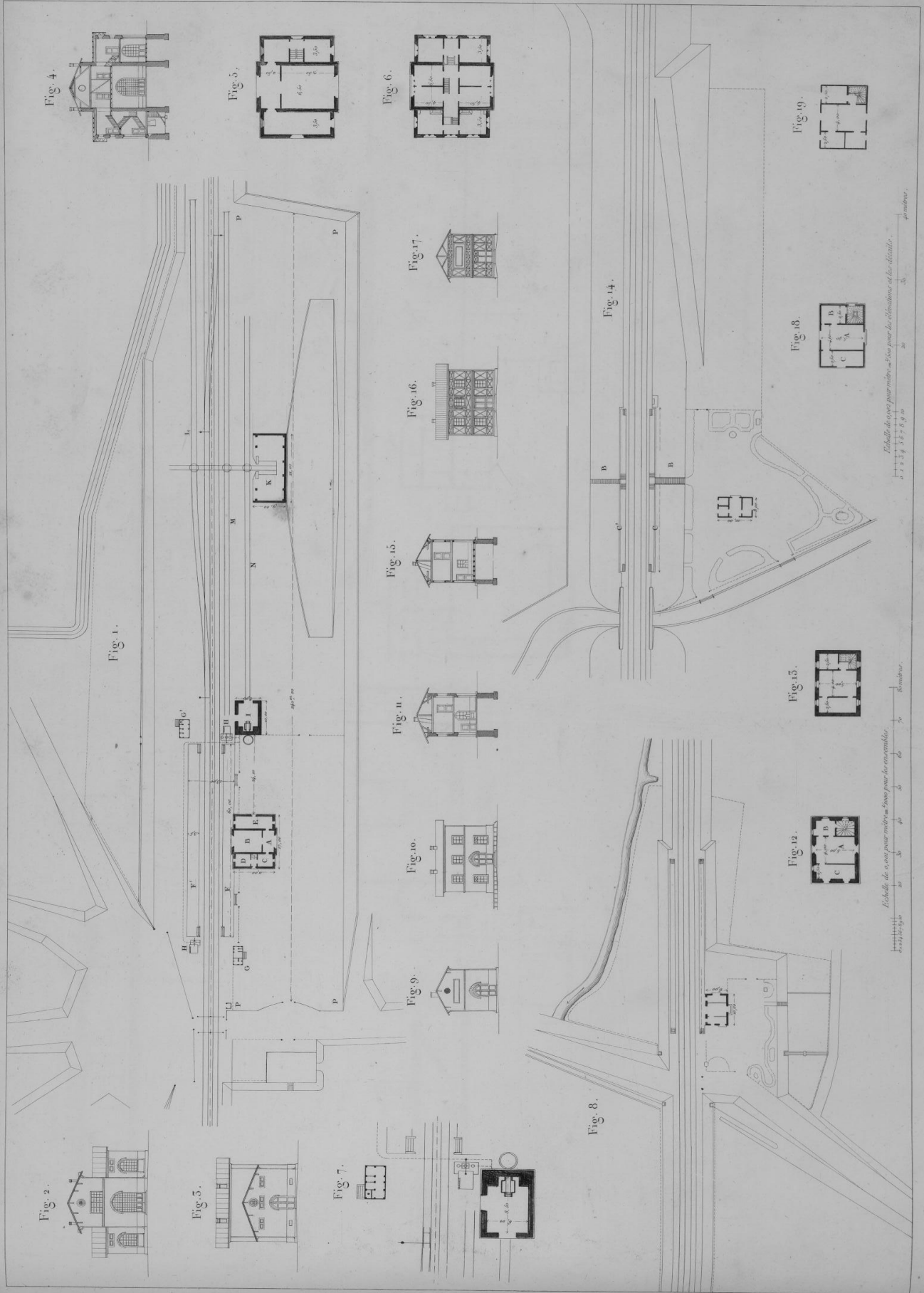



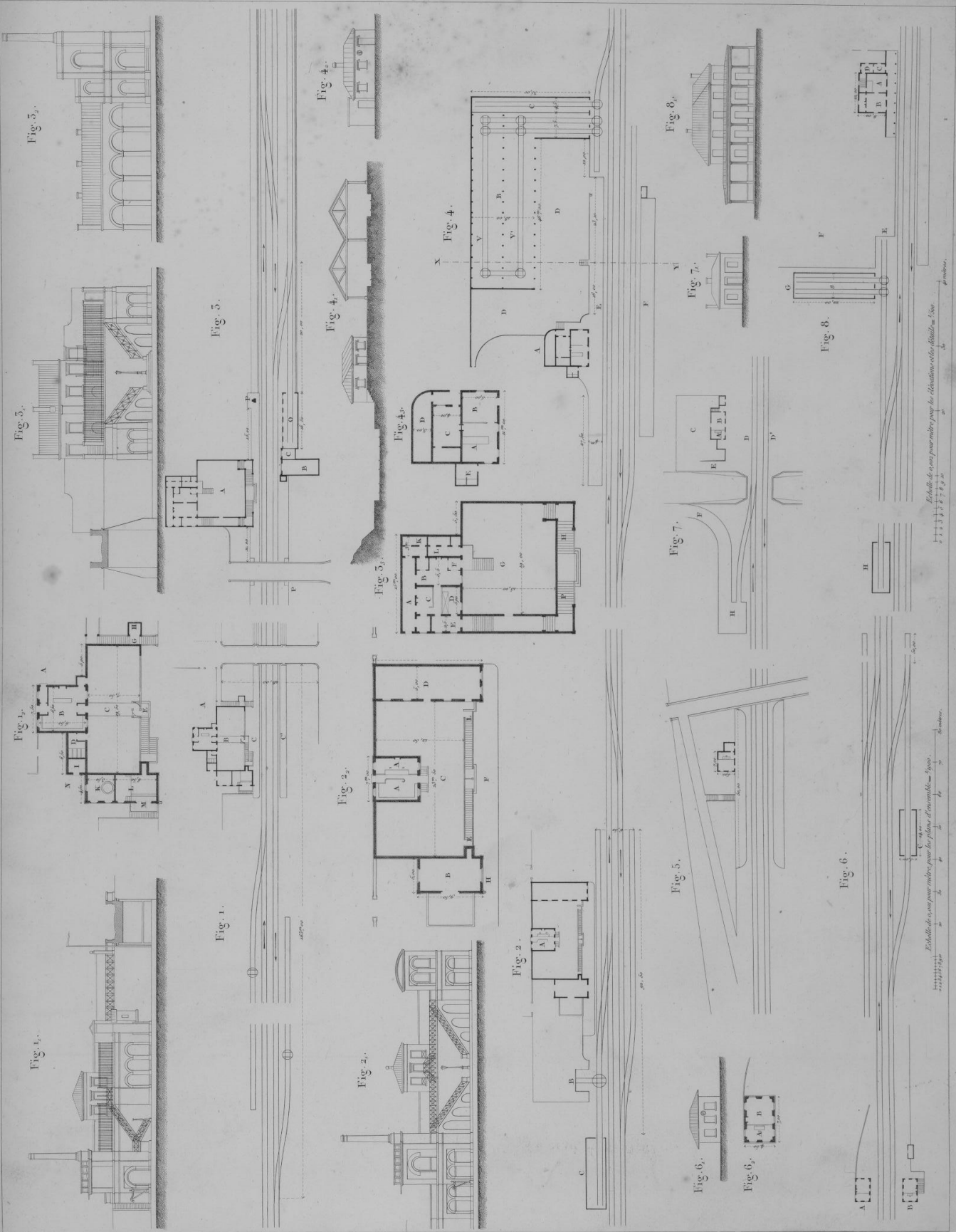

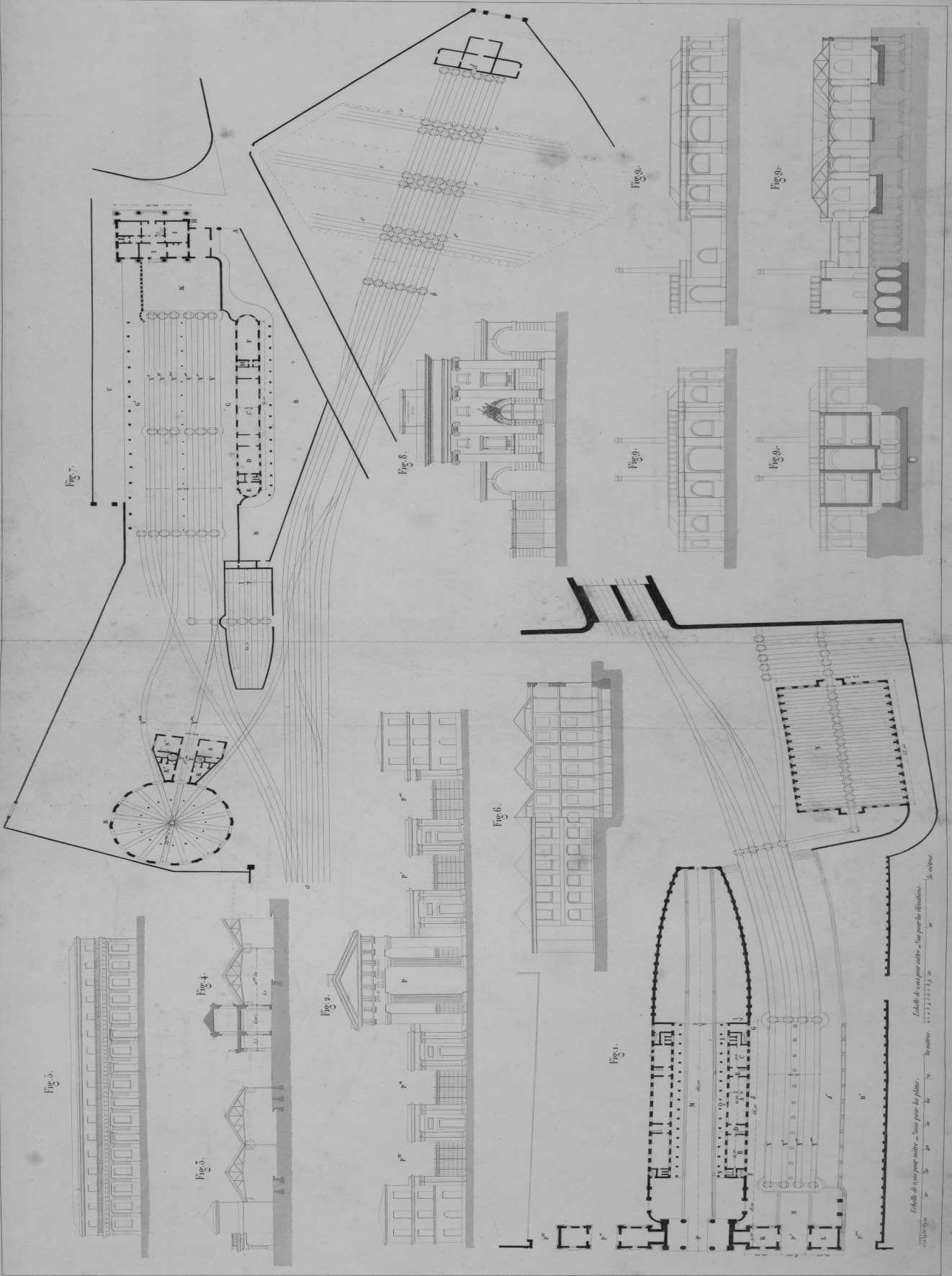

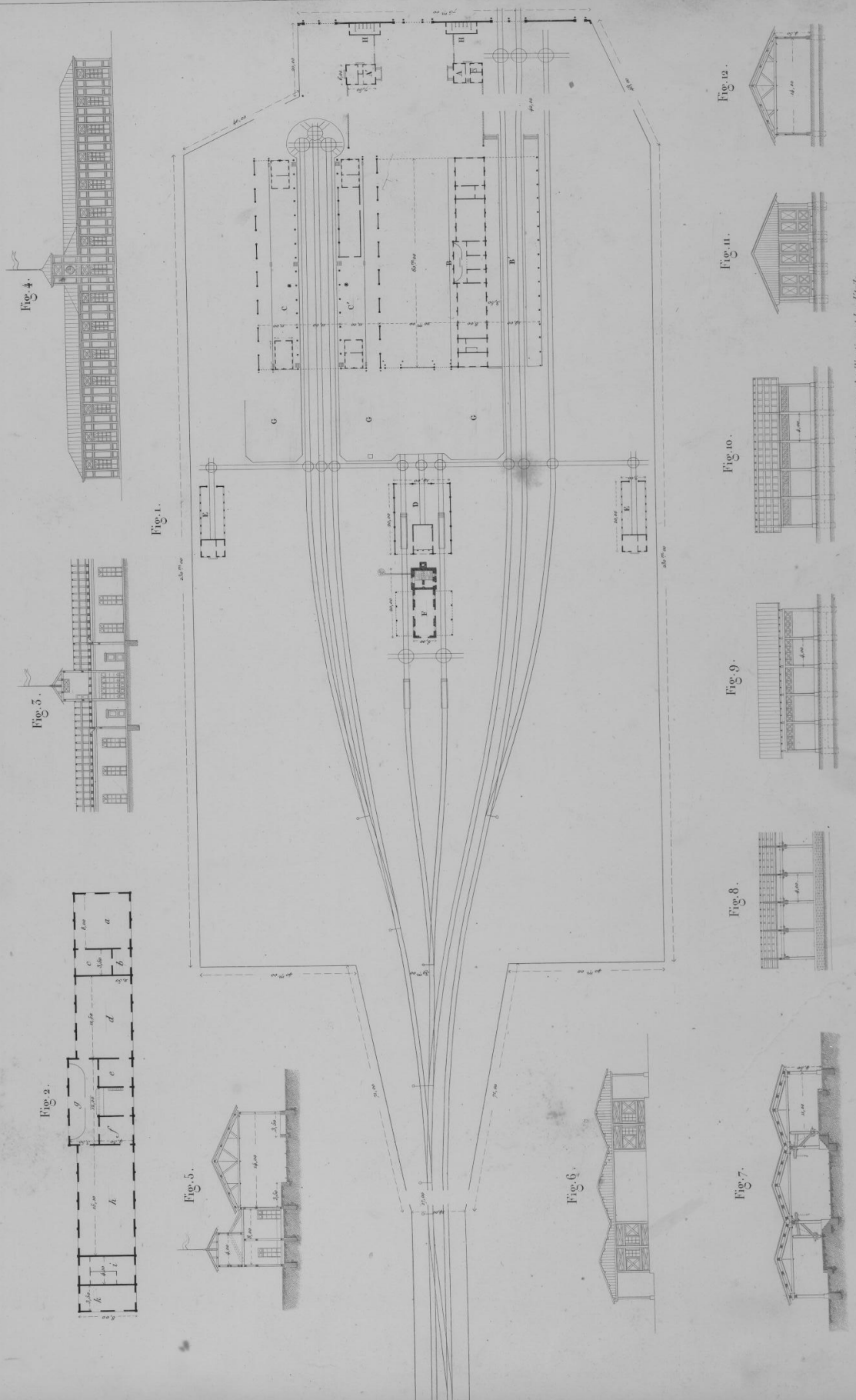

Gare du chemin de Strasbourg à Bâle, à Mulhouse.

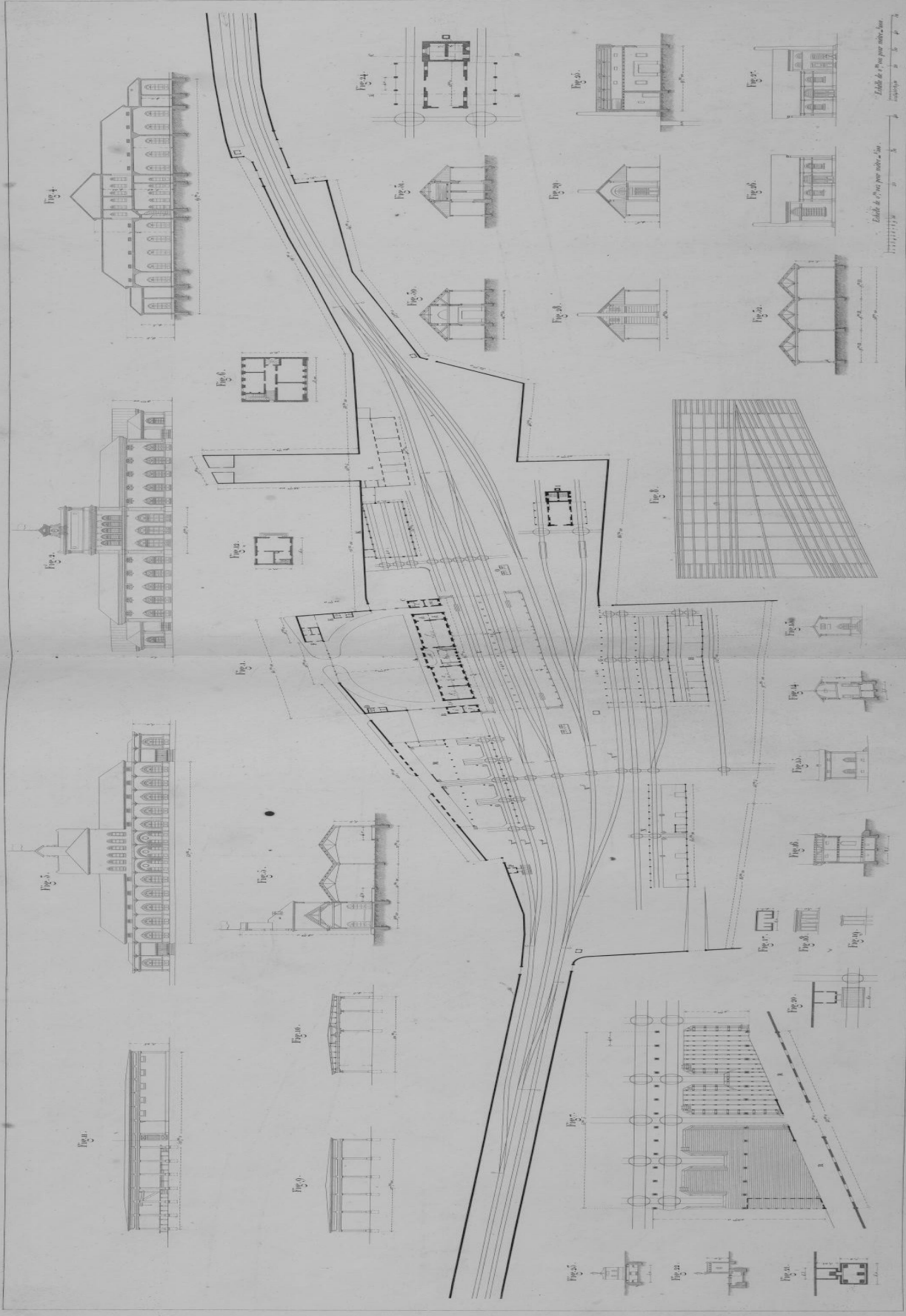

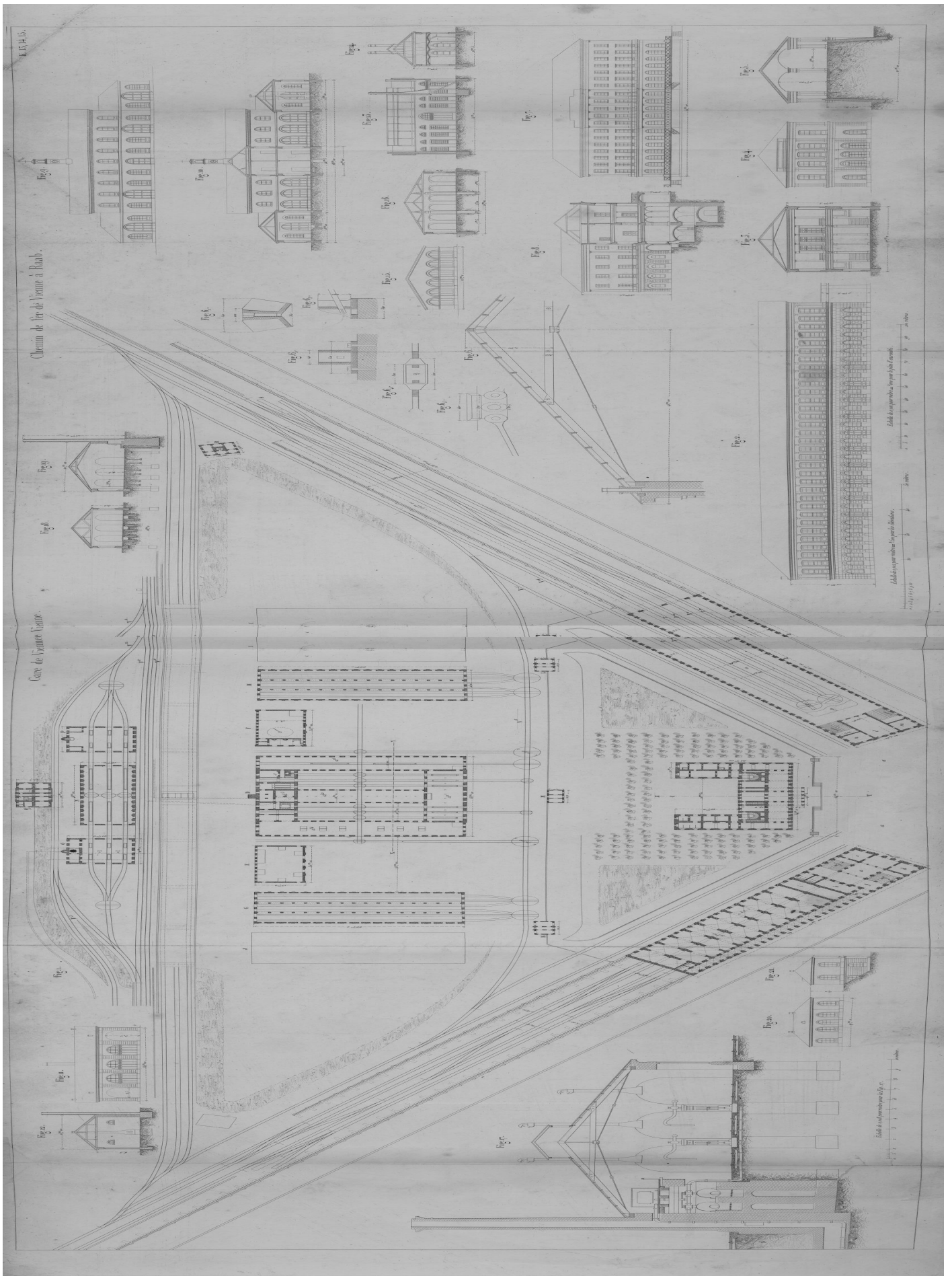



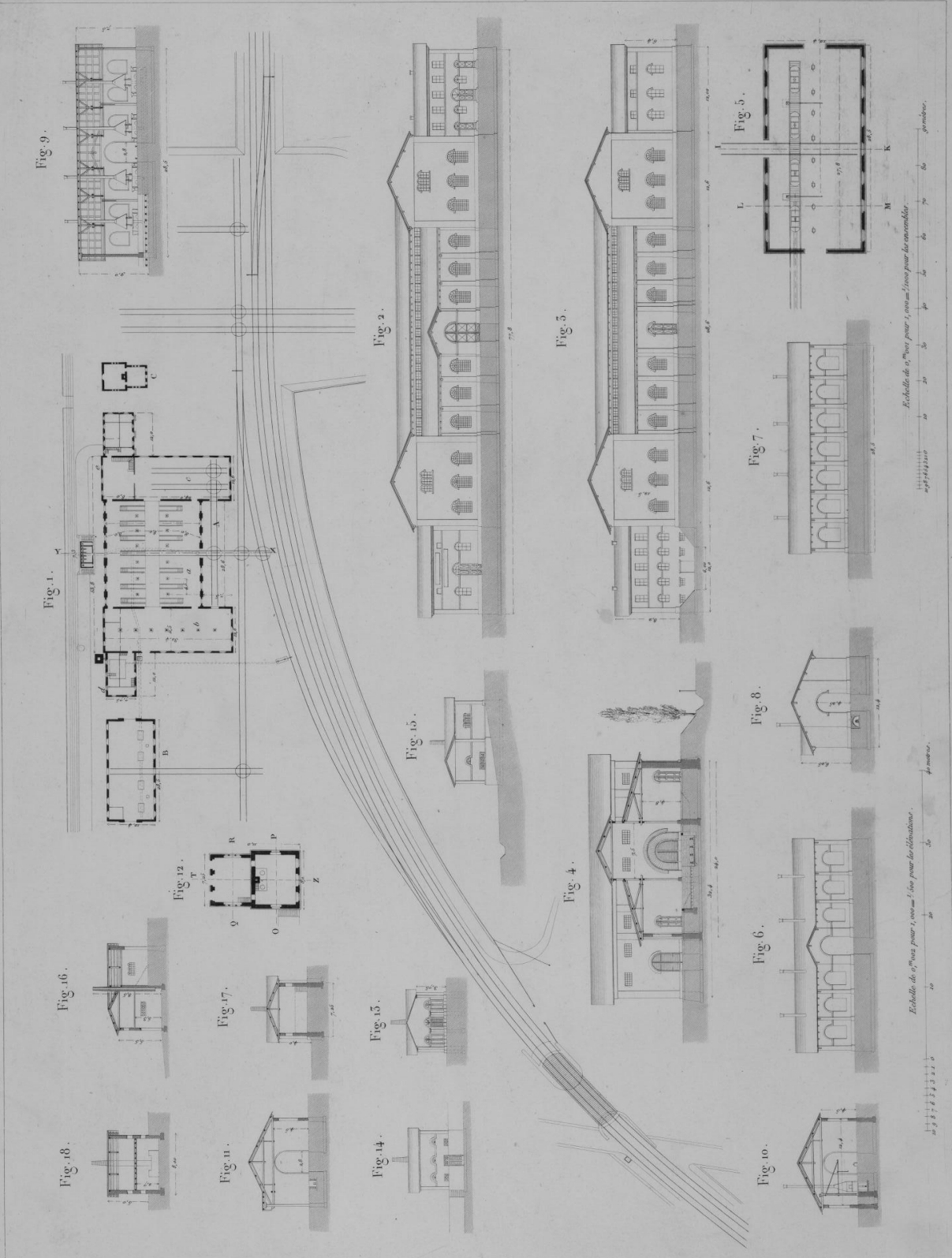

Deuxième partie de la gare du chemin de fer de Paris à Orléans. (Marchandises et départs)

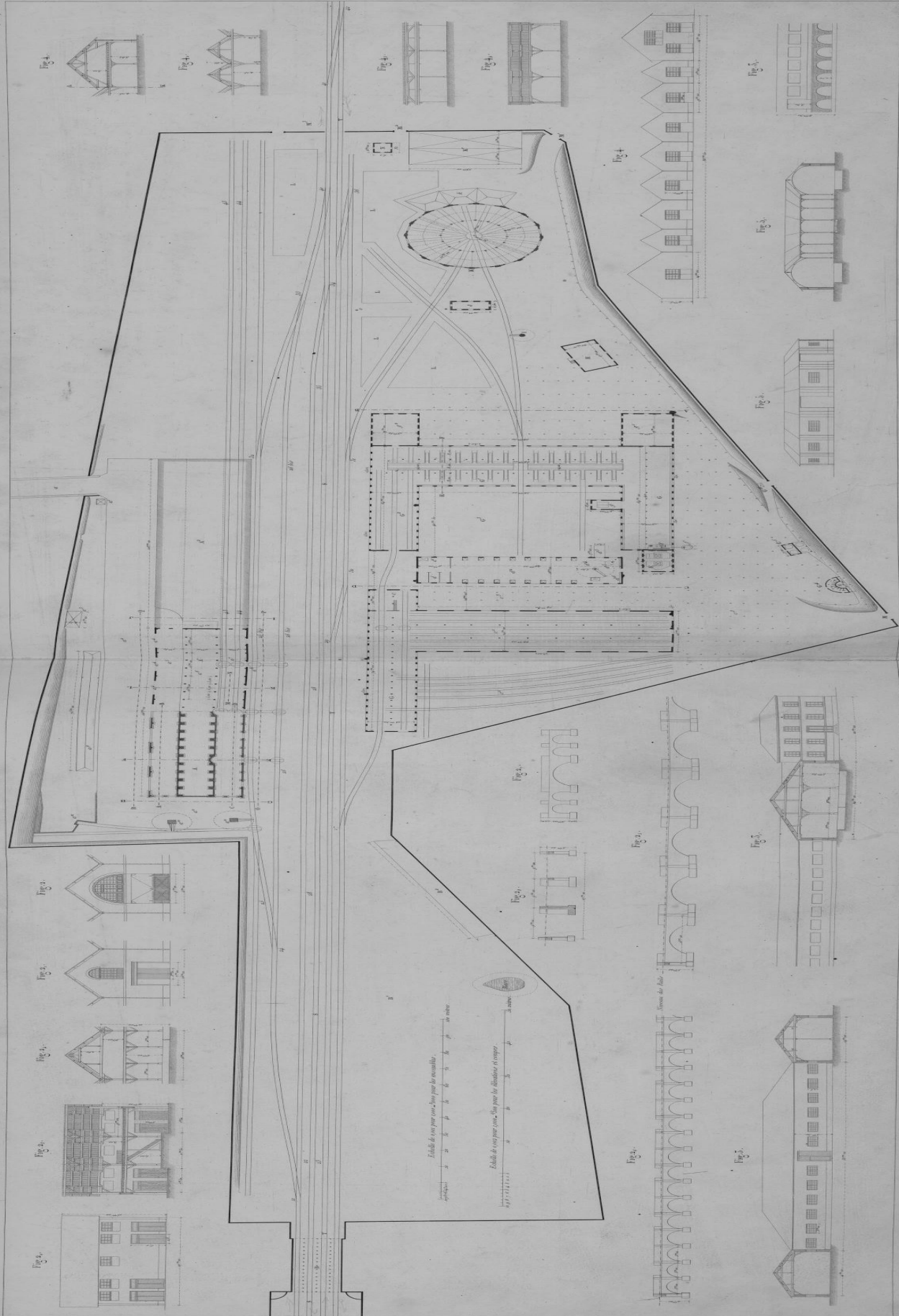



Gare d'Orléans du chemin de fer de Paris à Orléans.

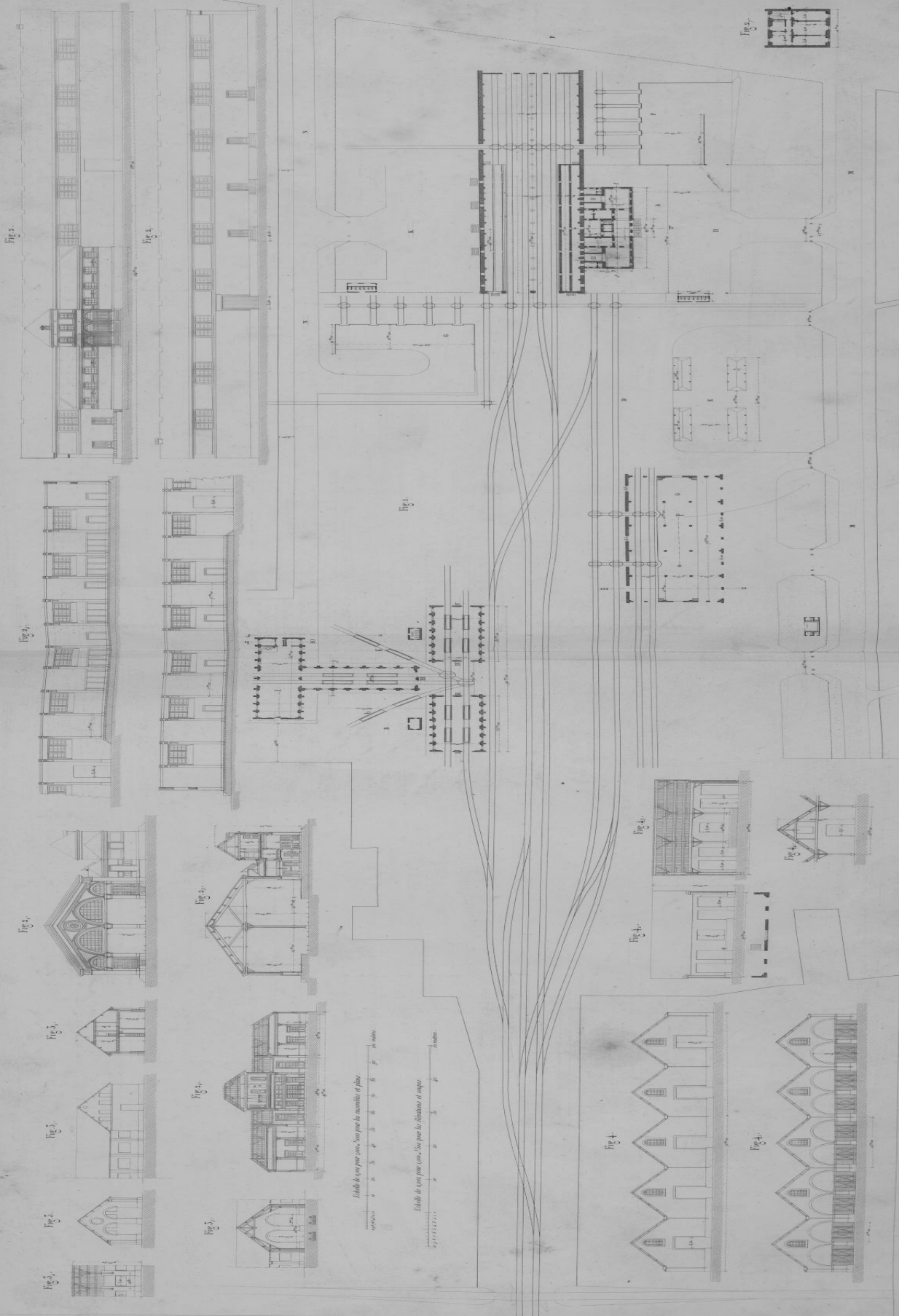

Stations de Mantes et de Vernon sur le chemin de fer de Paris a Rouen.

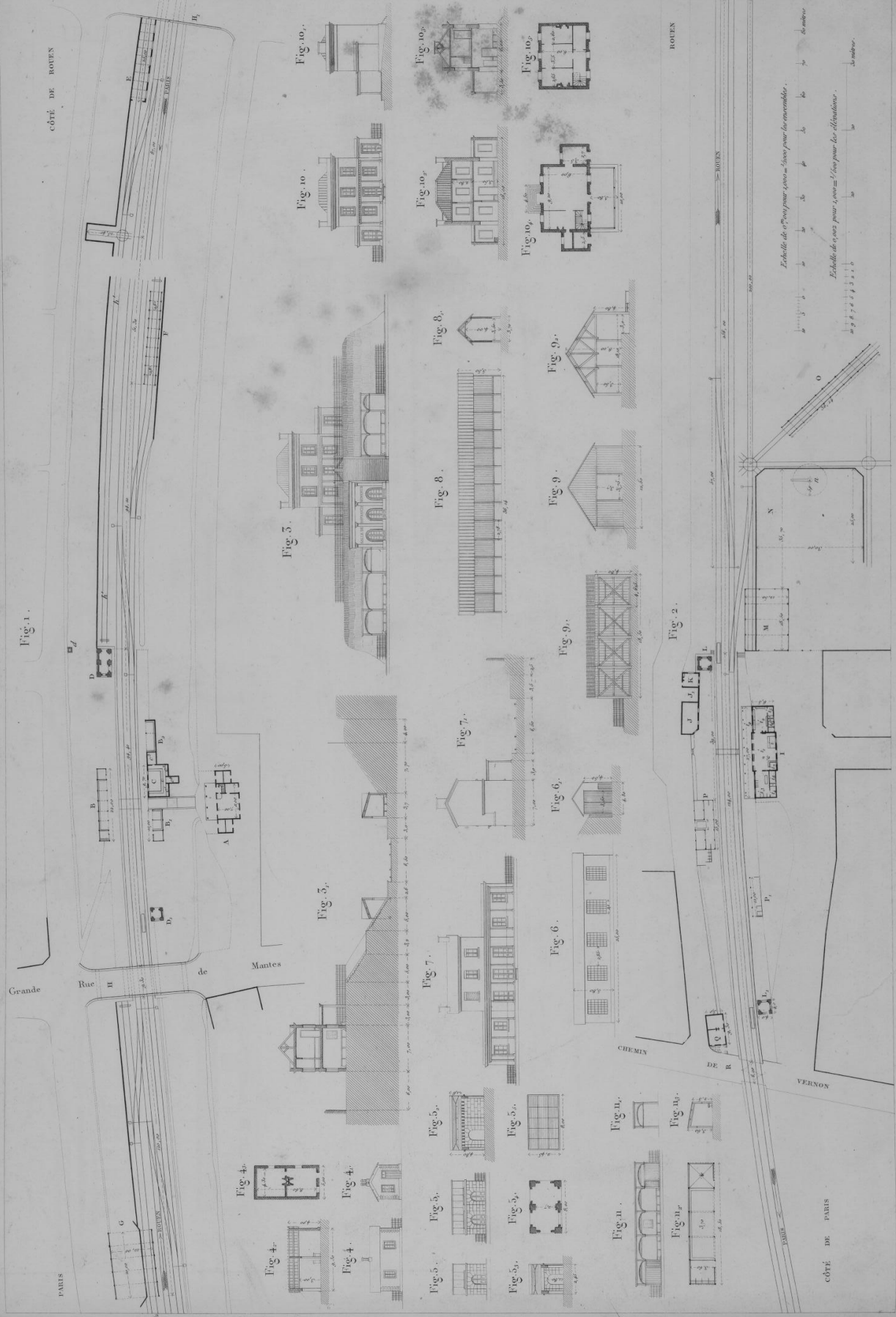

G. Mathias, Architecte, quai de Montparnasse, 15.

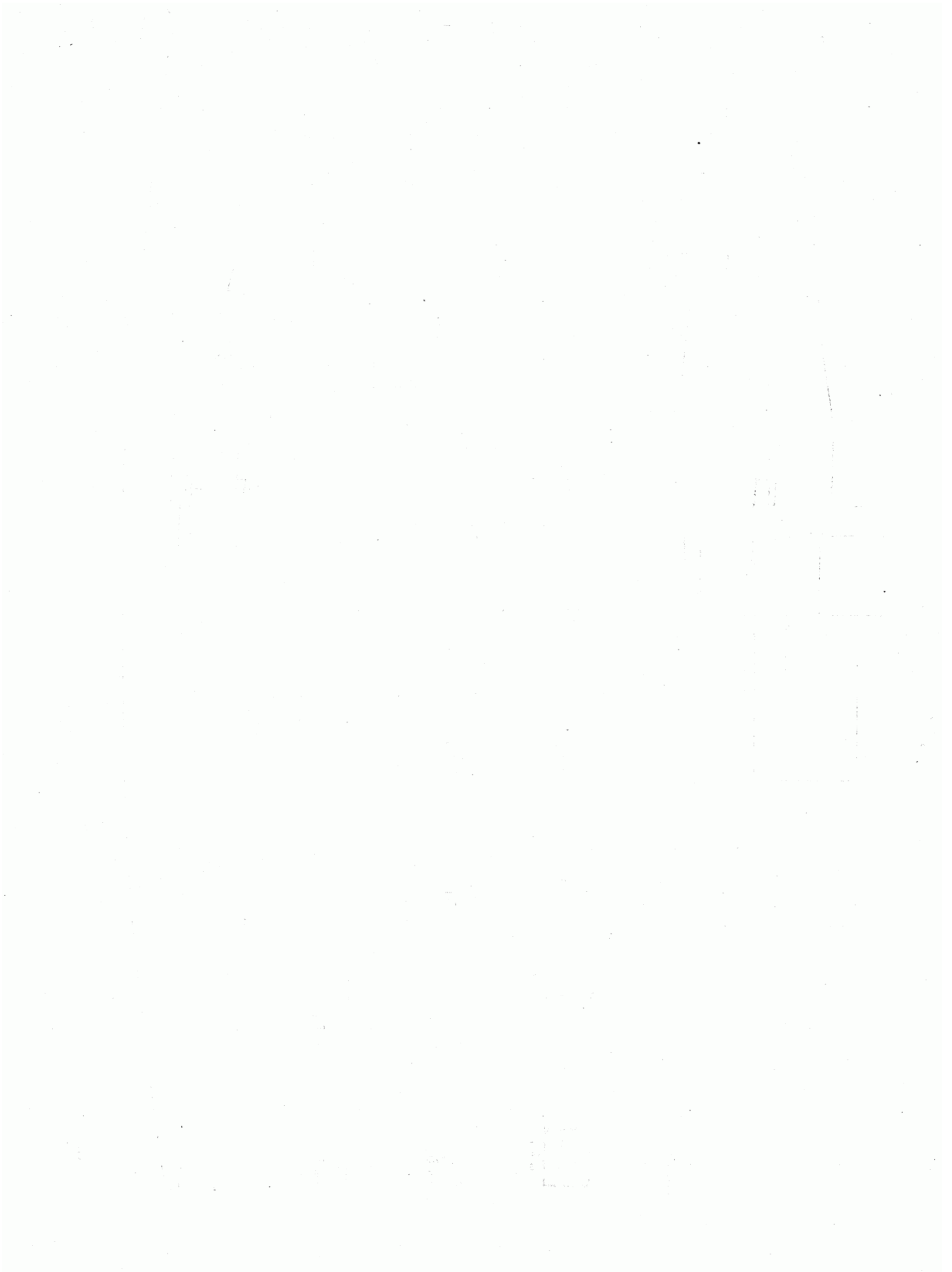



Gare de marchandises de Batignolles et ateliers de réparations de Sotteville du chemin de Paris à Rouen.

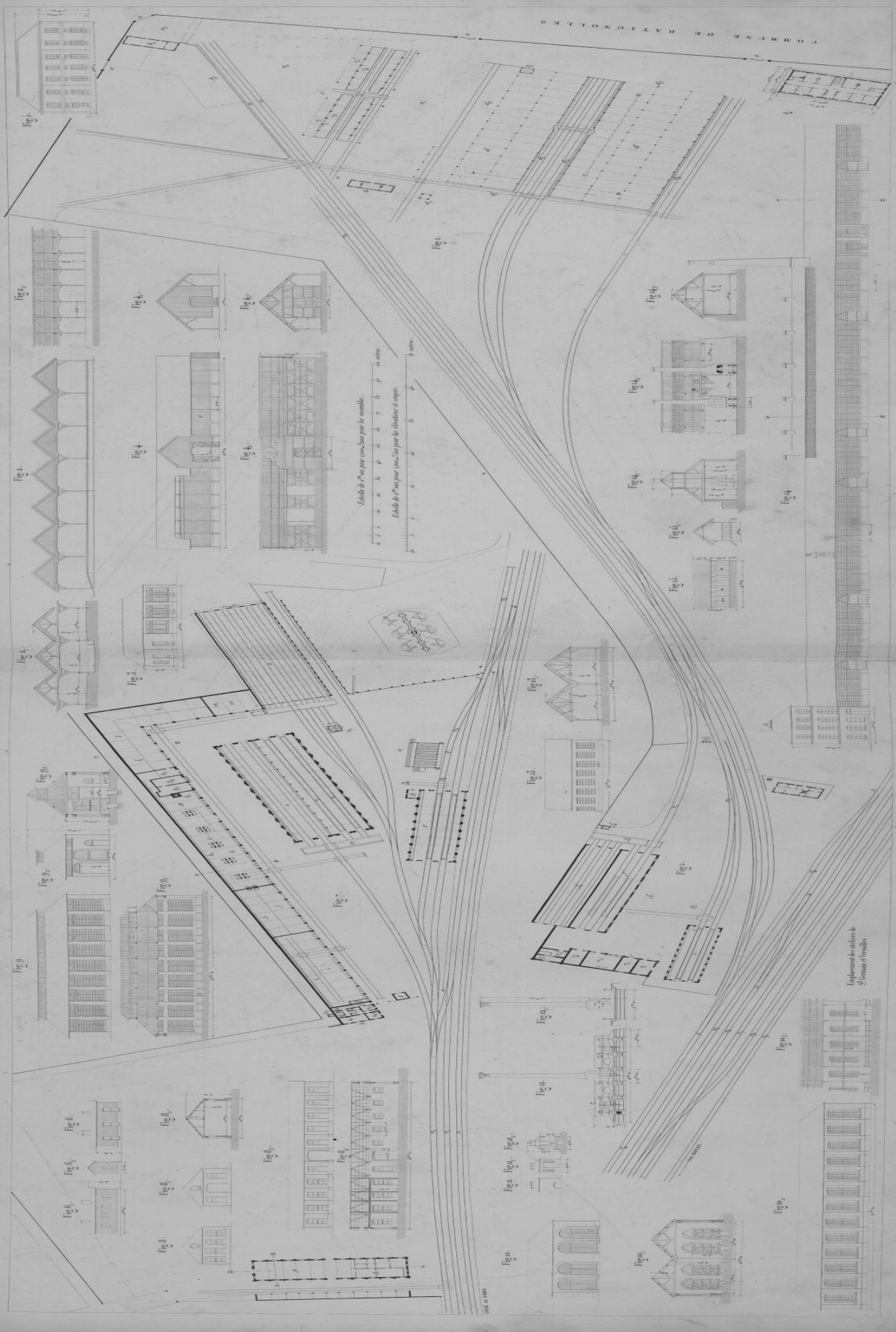



Fig. 1.

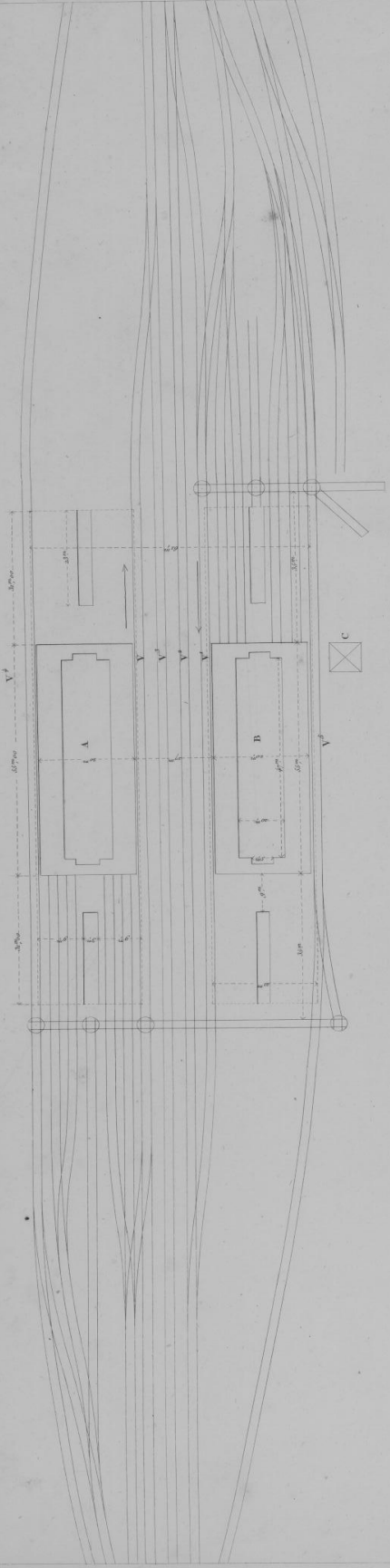

Fig. 2.

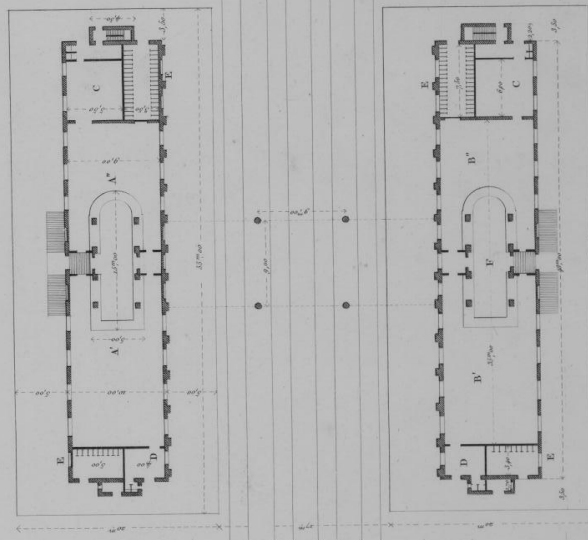

Fig. 3.

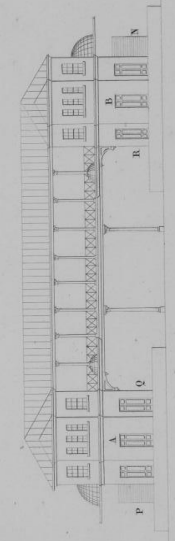

Fig. 4.

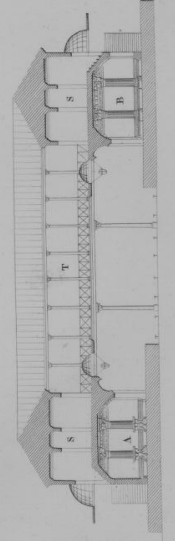

Fig. 5.

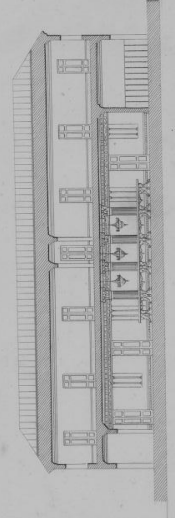
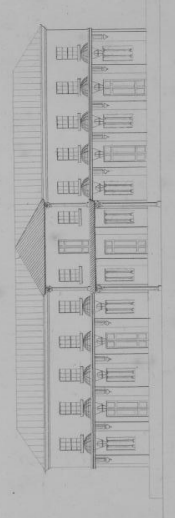

Fig. 6.



0 1 2 3 4 5 6 7 8 9 10
 Echelle de 0^m005 pour 1 mètre — 1/200 pour les autres fig.
 1 mètre

Gares d'Exnington (Ch. de Leeds à Derby), de Slough et de Reading (Ch. de Bristol).

N. 24. 55.

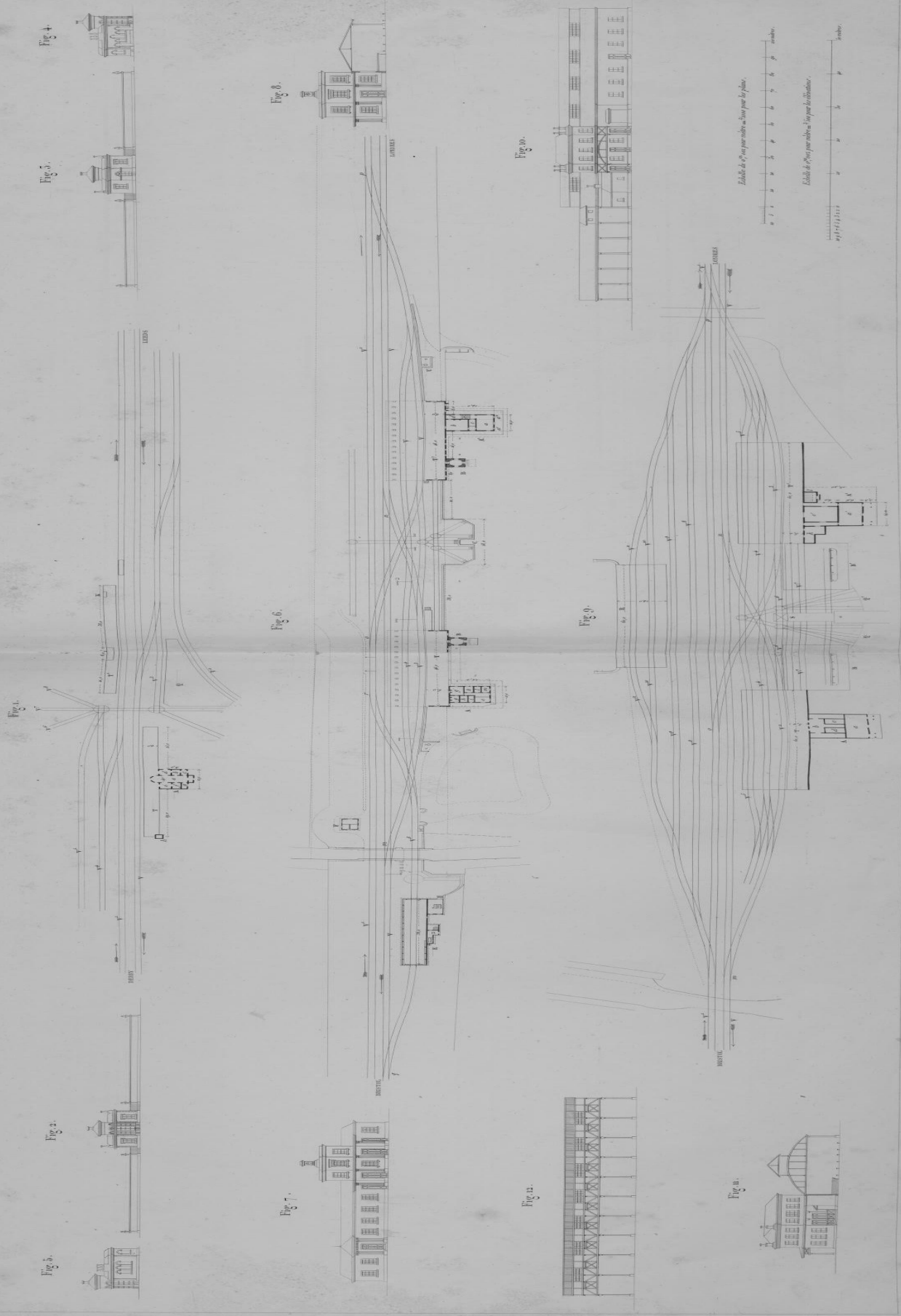



Fig. 2.

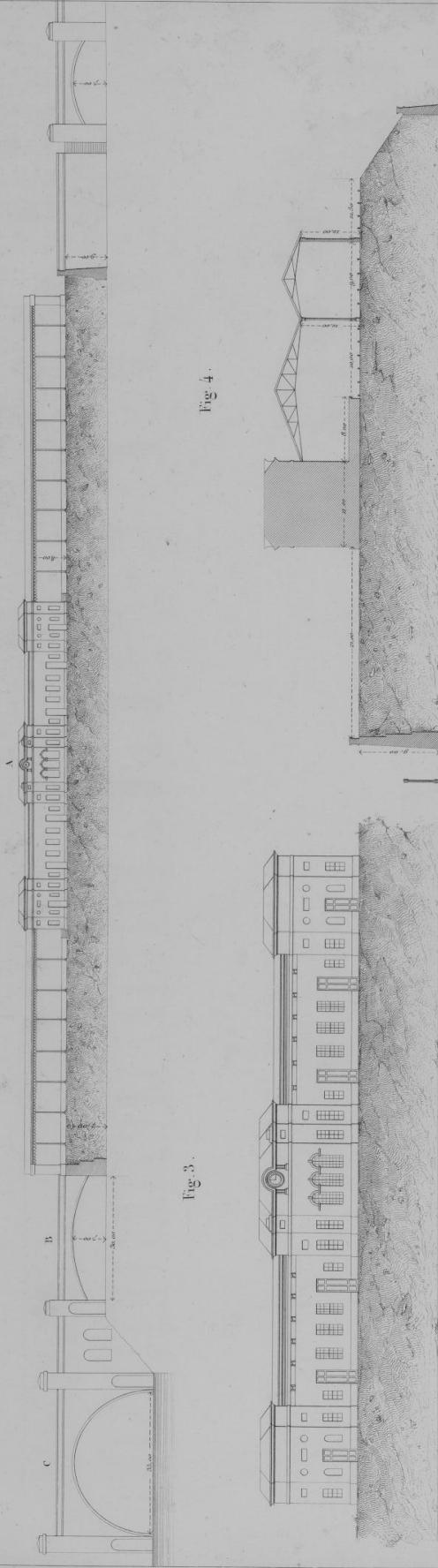

Fig. 3.

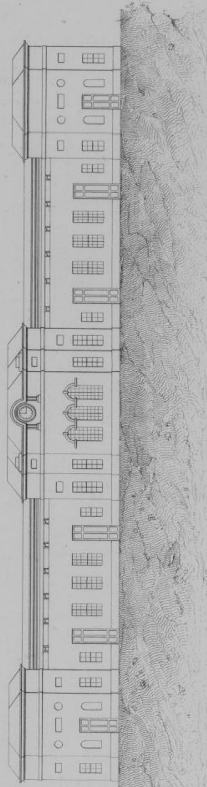

Fig. 4.

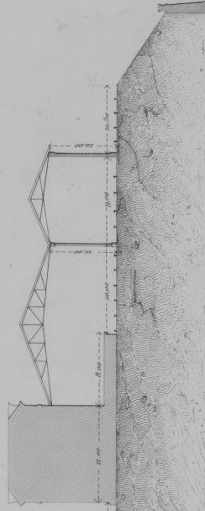
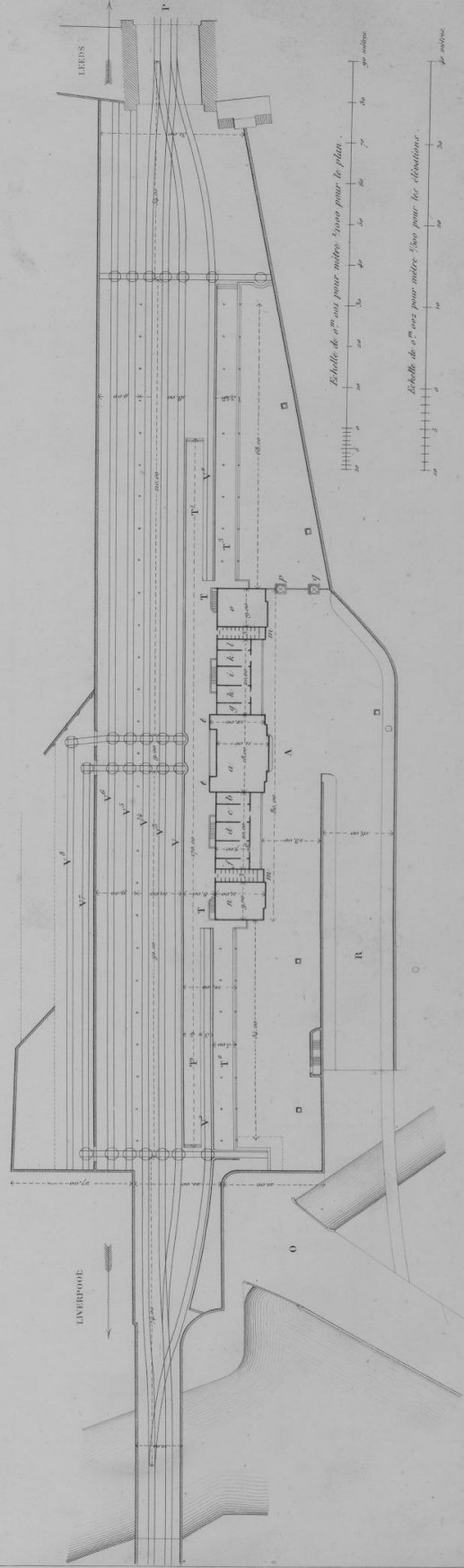
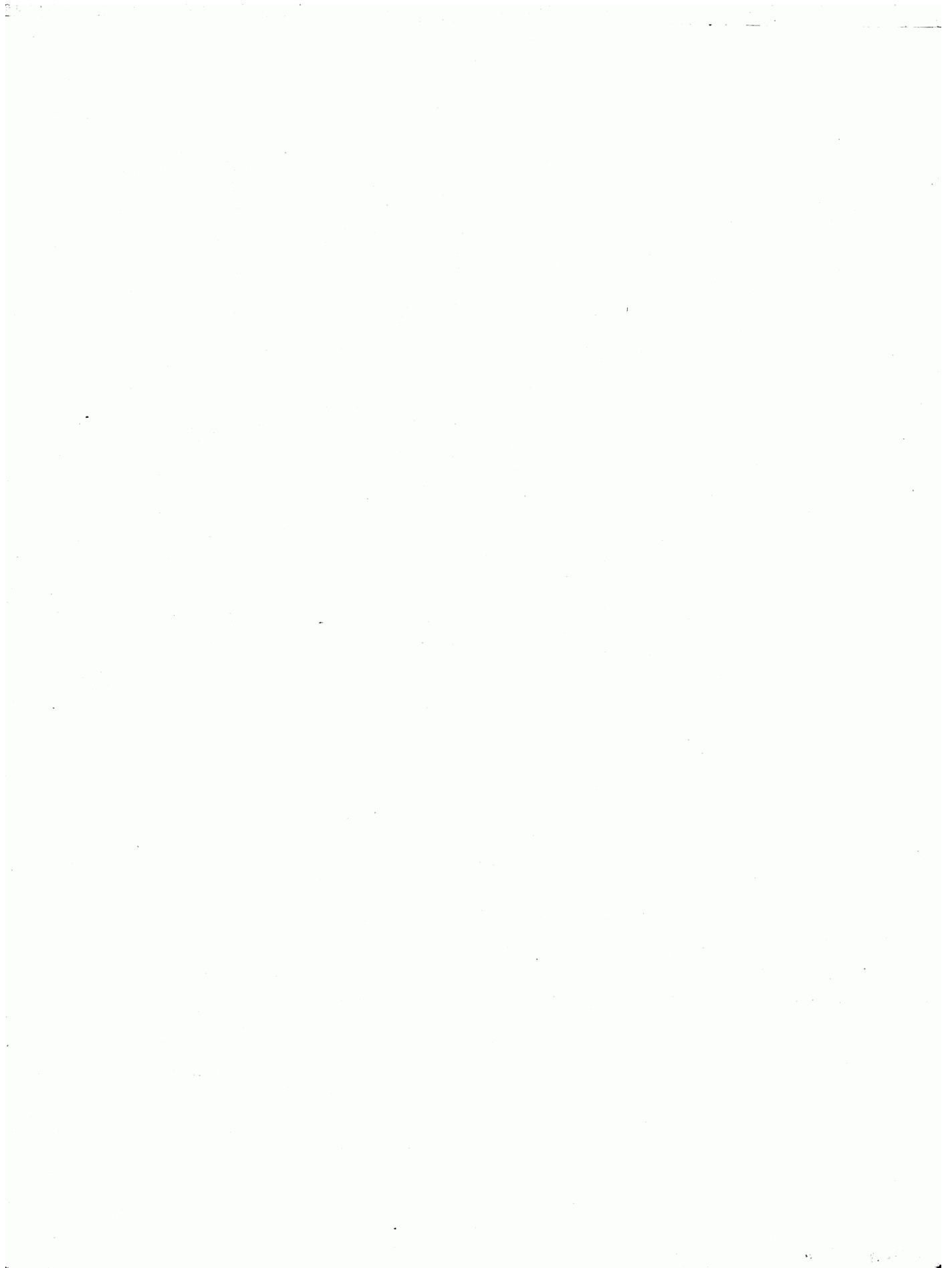
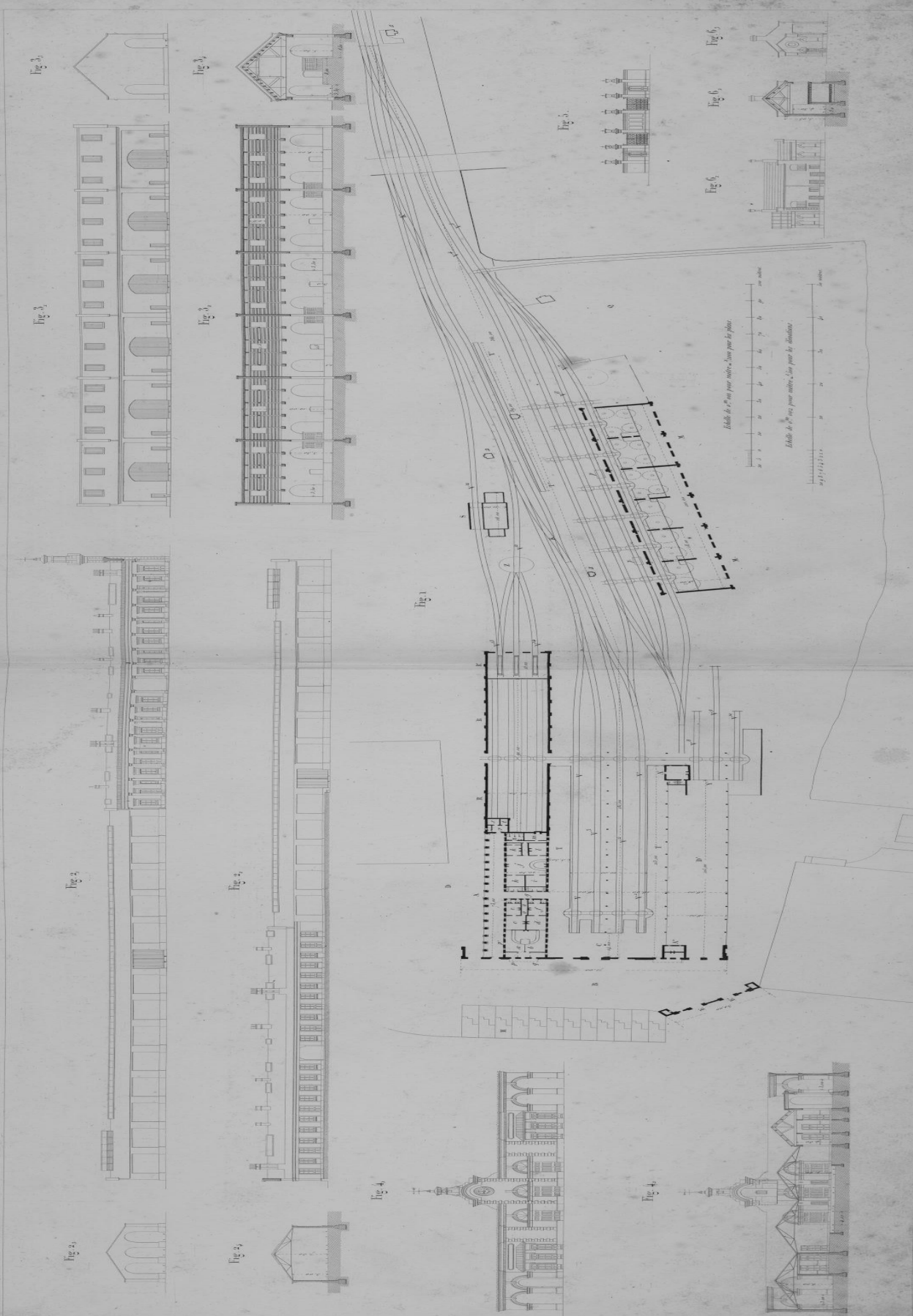
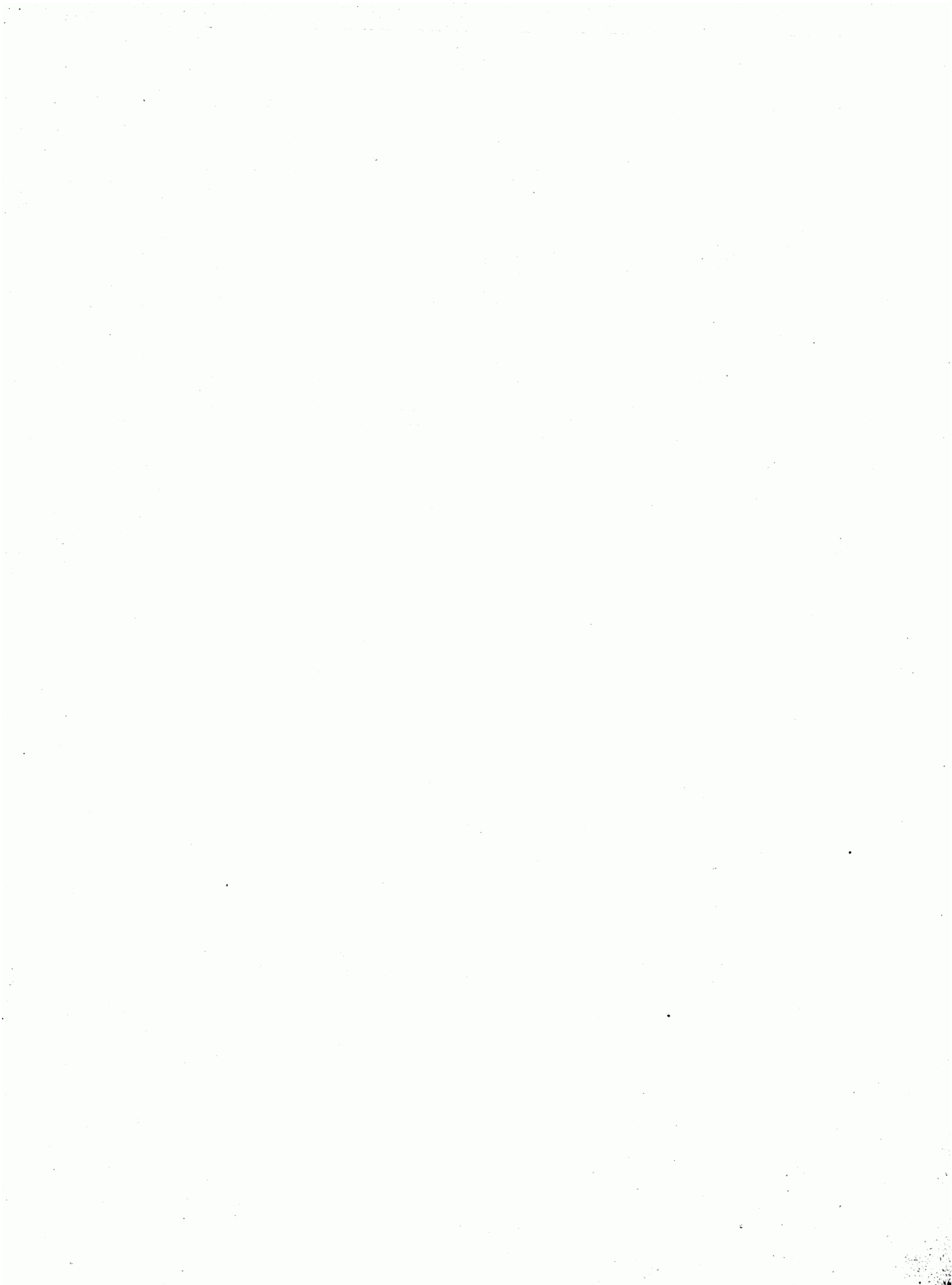

Fig. 1.









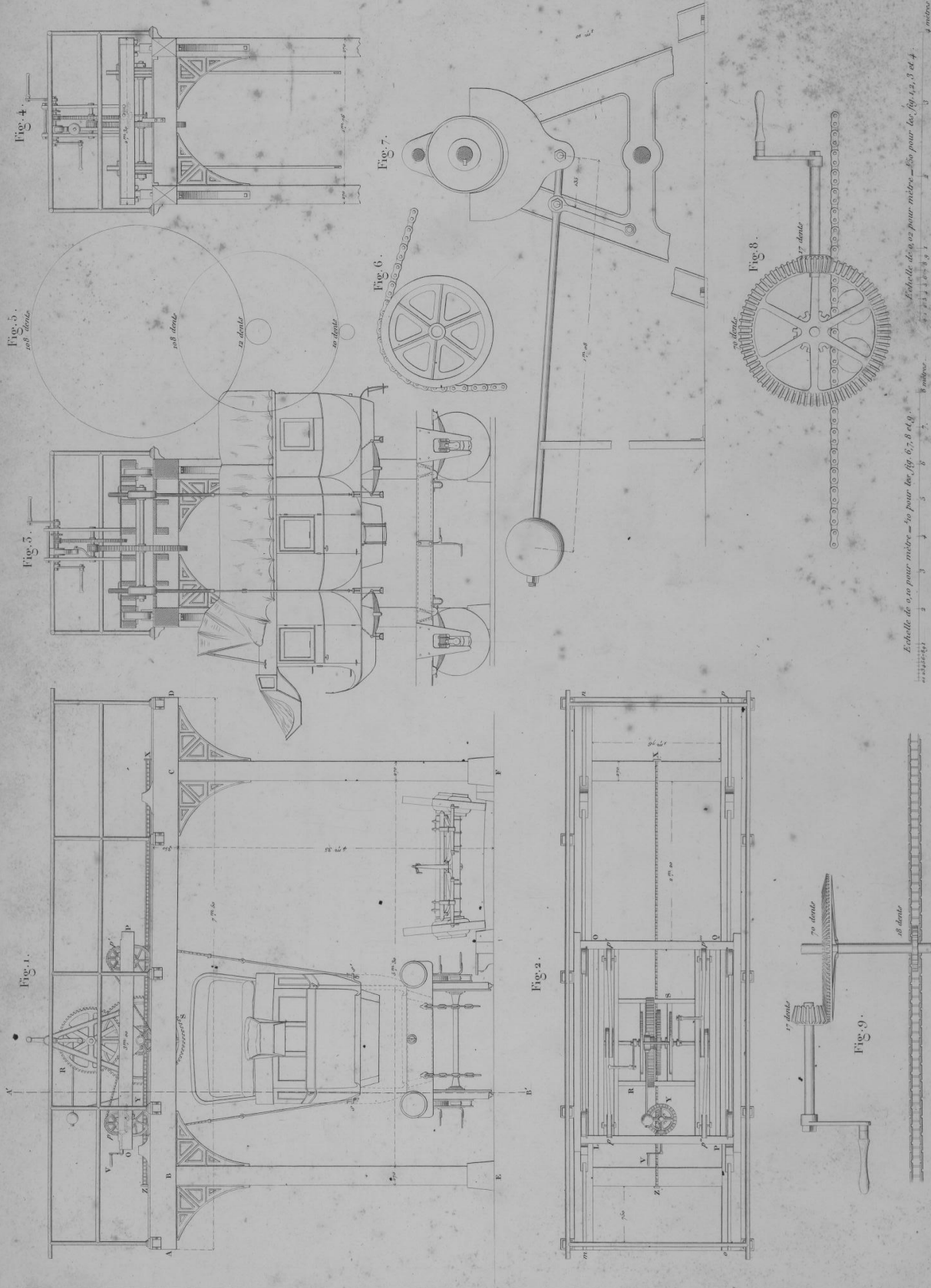

L. L. Mathias, Graveur, quai Malakoff 40.

